

B12FN - B12GN - B12HN

Pressure switches up to 300 bar with adjustable differential

Pressure switches for control and regulation of all fluids and non-explosive gases. Suitable for compression plants, boilers, tanks, autoclaves, ventilation plants, lubrication plants and in general whenever a pressure up to 300 bar must be controlled.



Dimensions (mm)

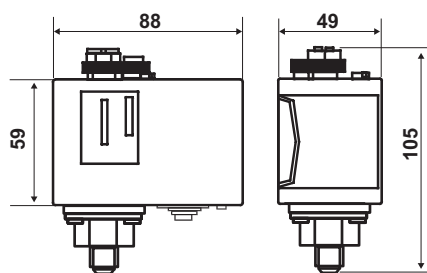

	Range bar	Differential* bar	Sensitive element max. pressure bar	Connection G 1/4	Protection degree	Availability
B12FN	12 ÷ 50	6 ÷ 15	60	male	IP40	in stock
B12GN	25 ÷ 150	12 ÷ 40	180	male	IP40	in stock
B12HN	60 ÷ 300	40 ÷ 80	350	male	IP40	in stock

WITH BLOCKING AND MANUAL RESET

B12FMN	12 ÷ 50	6 ÷ 15	60	male	IP40	on request
B12GMN	25 ÷ 150	12 ÷ 40	180	male	IP40	on request
B12HMN	60 ÷ 300	40 ÷ 80	350	male	IP40	on request

WATERPROOF CASING EXECUTION



Dimensions (mm)

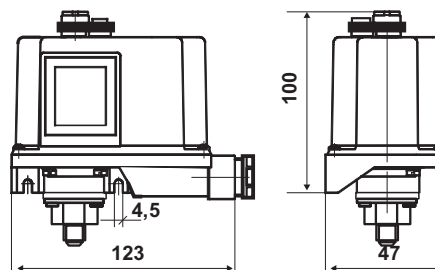

	Range bar	Differential* bar	Sensitive element max. pressure bar	Connection G 1/4	Protection degree	Availability
B12FNY	12 ÷ 50	6 ÷ 15	60	male	IP65	in stock
B12GNY	25 ÷ 150	12 ÷ 40	180	male	IP65	in stock
B12HNY	60 ÷ 300	40 ÷ 80	350	male	IP65	in stock

1 Bar = 100Kpa *The differential must be deducted from the range value.

ELECTRICAL FEATURES

Snap action SPDT microswitch, contacts in AgCdO.

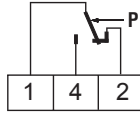

EXAMPLE OF ELECTRICAL WIRING

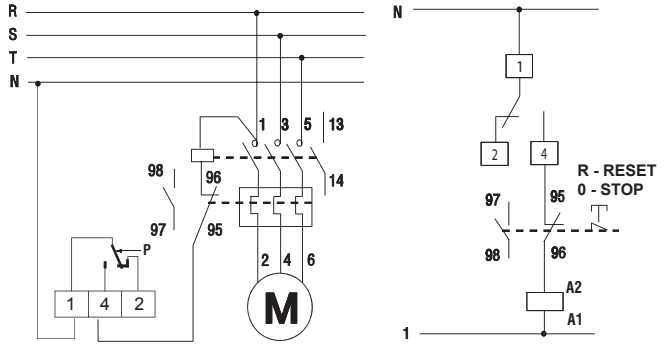

Nominal insulation tension	Ui	415V~
Continuous duty nominal current	Ith	16A
Operating nominal current Ie	220V~	380/415V~
Resistive load	AC-1	16A
Inductive load	AC-3	6A
Continuous current	DC-13	0,2A

HOMOLOGATION AND STANDARDS

Complies with EN 60947-1 and 60947-5-1 standards.

CE 0497

INSTALLATION

Direct installation on the pipe.

If these devices are used as control pressostats (pressure lack), verify that maximum pressure does not exceed maximum supported sensitive element pressure.

Possibility of mounting on metallic clamp, except for the waterproof casing versions.

MOUNTING MODEL

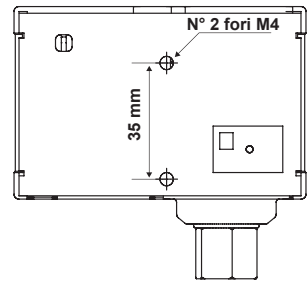

OPERATION

When pressure increases: 1-2 opens, 1-4 closes.

In case of fluid temperatures higher than the maximum allowed, connect the pressure switch to the pipe by inserting a metallic spiral between the pressure switch and the pipe to facilitate heat dispersion.

In the pressure switch with blocking and manual reset at maximum pressure, the reset takes place when the pressure is below the value set on differential.

FEATURES

Piston sensitive element, brass connection.

Metallic frame.

Cover in shockproof thermoplastic material.

Output connections with PVC cable gland.

Adjustable differential.

Male connection G 1/4.

Maximum temperature of the controlled fluid: 80°C.

Pressure switch body admissible temperature: 60°C.

Storage and transport temperature: -35 ÷ 60°C.

Unit weight: 0,47 Kg B12FN-B12GN.

Unit weight: 0,46 Kg B12HN.

ACCESSORIES



303298LA

G1/2 cable gland in V0 self-extinguishing, shockproof thermoplastic material for output connections.



2593367

Protection casing IP44.

B12MN

Blocking pressure switches with manual reset

Blocking and safety pressure controls with manual reset, suitable for steam generators and fluids and inert gases in general.

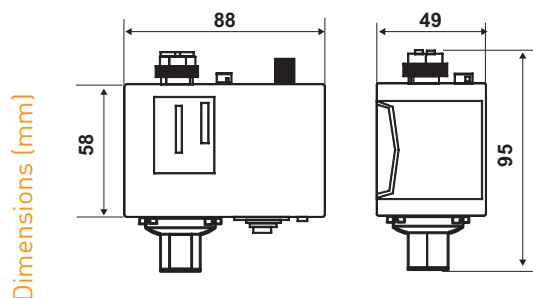

Dimensions (mm)

	Range bar	Differential* bar	Sensitive element max. pressure bar	Connection G 1/4	Protection degree	Availability
B12MN	1 ÷ 5 bar	0,6 fixed	9	female	IP40	in stock

WATERPROOF CASING EXECUTION

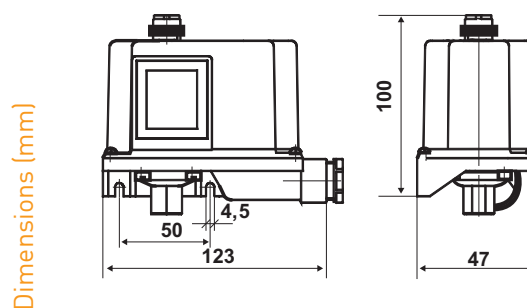

Dimensions (mm)

	Range bar	Differential* bar	Sensitive element max. pressure bar	Connection G 1/4	Protection degree	Availability
B12MNY	1 ÷ 5 bar	0,6 fixed	9	female	IP65	in stock

1 Bar = 100Kpa *The differential must be deducted from the range value.

ELECTRICAL FEATURES

Snap action SPDT microswitch, with manual reset, contacts in AgCdO.

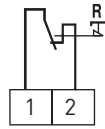

EXAMPLE OF ELECTRICAL WIRING

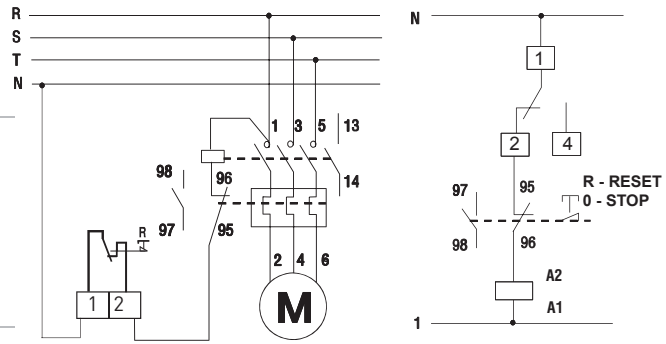

Nominal insulation tension	Ui	415V~	
Continuous duty nominal current	Ith	16A	
Operating nominal current Ie		220V~	380/415V~
Resistive load	AC-1	-	16A
Inductive load	AC-3	-	6A
Continuous current	DC-13	0,2A	-

HOMOLOGATION AND STANDARDS

Complies with EN 60947-1 and EN 60947-5-1 standards.

I.S.P.E.S.L. homologation.

Corresponding to the requirements provided in the R.3.B. chapter of the applied technical specifications of D.M. dated December 1st 1975 R.3.B.

CE 0497

INSTALLATION

Direct installation on the pipe.

Pressure element connection G 1/4.

In case of fluid temperatures higher than the maximum allowed, connect the pressure switch to the pipe by inserting a metallic spiral between the pressure switch and the pipe to facilitate heat dispersion.

Possibility of mounting on metallic clamp, except for the waterproof casing versions.

MOUNTING MODEL

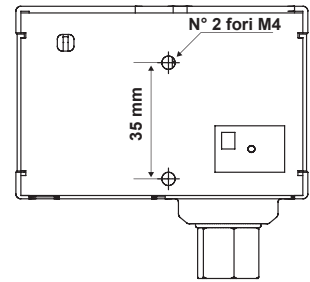

OPERATION

When pressure increases: 1-2 opens.

For use in connection with a regulation pressostat.

FEATURES

Calibration screw made to be welded after testing.

Connection G 1/4.

Sensitive element with stainless steel membrane, laser welded.

Metallic frame.

Cover in shockproof thermoplastic material.

Output connections with PVC cable gland.

Maximum temperature of the controlled fluid: 120°C.

Pressure switch body admissible temperature: -35÷60°C.

Storage and transport temperature: -35÷60°C.

Unit weight: 0,46 Kg.

ACCESSORIES



303298LA

G1/2 cable gland in V0 self-extinguishing, shockproof thermoplastic material for output connections.



2593367

Protection casing IP44.

B12CN - B12DN - B12EN

Pressure switches up to 28 bar with adjustable differential

Pressure switches for control and regulation of all fluids and non-explosive gases. Suitable for compression plants, boilers, tanks, autoclaves, ventilation plants, lubrication plants.

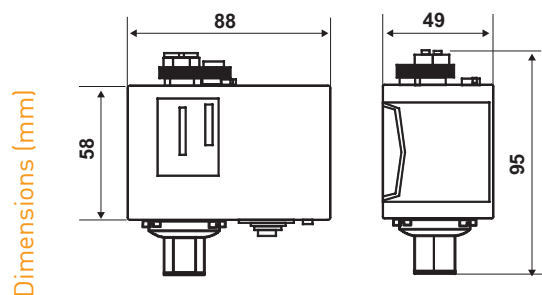

	Range bar	Differential* bar	Sensitive element max. pressure bar	Connection G 1/4	Protection degree	Availability
B12CN	-0,2 ÷ 8	0,6 ÷ 3	9	female	IP40	in stock
B12DN	5 ÷ 16	1 ÷ 3,5	18	female	IP40	in stock
B12EN	8 ÷ 28	2 ÷ 6	32	female	IP40	in stock
B12CRN	-0,2 ÷ 8	0,6 ÷ 3	9	SAE	IP40	in stock
B12ERN	8 ÷ 28	2 ÷ 6	32	SAE	IP40	in stock
B12CN4	-0,2 ÷ 8	0,6 ÷ 3	9	male	IP40	on request
B12DN4	5 ÷ 16	1 ÷ 3,5	18	male	IP40	on request

WITH BLOCKING AND MANUAL RESET

B12CMN	1 ÷ 8	0,6 ÷ 3	9	female	IP40	on request
B12DMN	5 ÷ 16	1 ÷ 3,5	18	female	IP40	on request
B12EMN	8 ÷ 28	2 ÷ 6	32	female	IP40	on request

WATERPROOF CASING EXECUTION

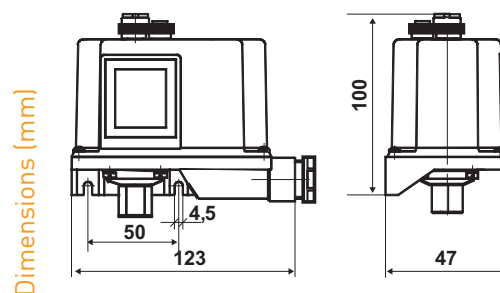

	Range bar	Differential* bar	Sensitive element max. pressure bar	Connection G 1/4	Protection degree	Availability
B12CNY	-0,2 ÷ 8	0,6 ÷ 3	9	female	IP65	in stock
B12DNY	5 ÷ 16	1 ÷ 3,5	18	female	IP65	in stock
B12ENY	8 ÷ 28	2 ÷ 6	32	female	IP65	in stock
B12CRNY	-0,2 ÷ 8	0,6 ÷ 3	9	SAE	IP65	in stock
B12ERNY	8 ÷ 28	2 ÷ 6	32	SAE	IP65	in stock

1 Bar = 100Kpa *The differential must be deducted from the range value.

ELECTRICAL FEATURES

Snap action SPDT microswitch, contacts in AgCdO.

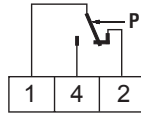

EXAMPLE OF ELECTRICAL WIRING

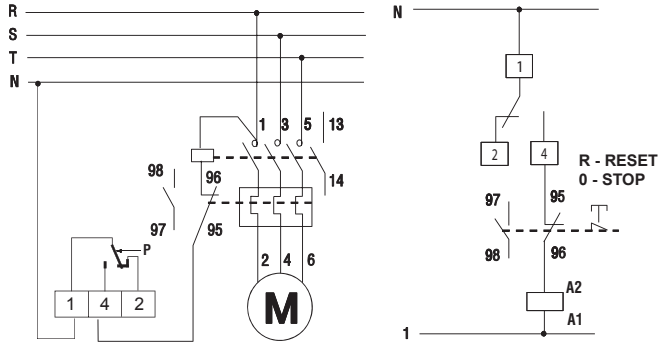

Nominal insulation tension	Ui	415V~	
Continuous duty nominal current	Ith	16A	
Operating nominal current le		220V~	380/415V~
Resistive load	AC-1	-	16A
Inductive load	AC-3	-	6A
Continuous current	DC-13	0,2A	-

HOMOLOGATION AND STANDARDS

Complies with EN 60947-1 and 60947-5-1 standards.

CE 0497

INSTALLATION

Direct installation on the pipe.

Pressure element connection G 1/4.

In case of fluid temperatures higher than the maximum allowed, connect the pressure switch to the pipe by inserting a metallic spiral between the pressure switch and the pipe to facilitate heat dispersion.

Possibility of mounting on metallic clamp, except for the waterproof casing versions.

MOUNTING MODEL

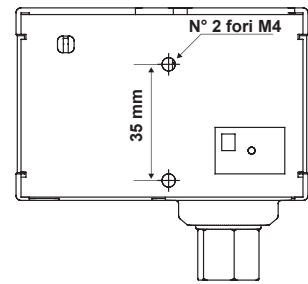

OPERATION

When pressure increases: 1-2 opens, 1-4 closes.

In the pressure switch with blocking and manual reset at maximum pressure, the reset takes place when the pressure is below the value set on differential.

FEATURES

Sensitive element with stainless steel membrane, laser welded.

Metallic frame.

Cover in shockproof thermoplastic material.

Output connections with PVC cable gland.

Fixed differential.

Female connection G 1/4 (17 mm key).

Maximum temperature of the controlled fluid: 120 °C.

Pressure switch body admissible temperature: -35 ÷ 60°C.

Storage and transport temperature: -35 ÷ 60°C.

Unit weight: 0,43 Kg B12AN.

Unit weight: 0,44 Kg B12BN.

ACCESSORIES



303298LA

G1/2 cable gland in V0 self-extinguishing, shockproof thermoplastic material for output connections.



2593367

Protection casing IP44.

B12AN - B12BN

Vacuum pressure switches up to - 0.82 bar

Pressure switches up to 2 bar

To adjust vacuum values in the pumps (B12AN) or to control pressure values of tanks or steam generators where it is required a low differential (B12BN).

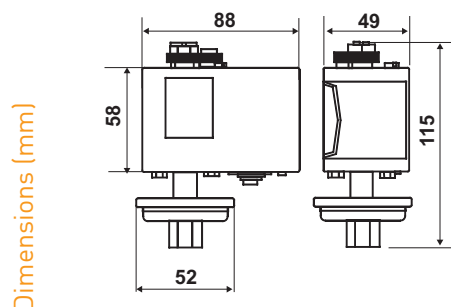

	Range bar	Differential* bar	Sensitive element max. pressure bar	Connection G 1/4	Protection degree	Availability
B12AN	-0,82 ÷ 0	0,1 fixed	2,5	female	IP40	in stock
B12AN4	-0,82 ÷ 0	0,1 fixed	2,5	male	IP40	on request
B12BN	0,2 ÷ 2	0,1 ÷ 0,5	4	female	IP40	in stock

WATERPROOF CASING EXECUTION

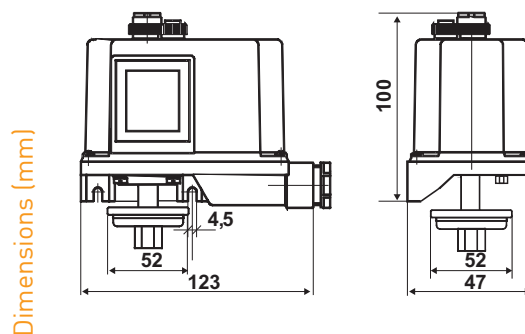

	Range bar	Differential* bar	Sensitive element max. pressure bar	Connection G 1/4	Protection degree	Availability
B12ANY	-0,82 ÷ 0	0,1 fixed	2,5	female	IP65	in stock
B12BNY	0,2 ÷ 2	0,1 ÷ 0,5	4	female	IP65	in stock

ELECTRICAL FEATURES

Snap action SPDT microswitch, contacts in AgCdO.

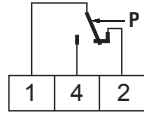

EXAMPLE OF ELECTRICAL WIRING

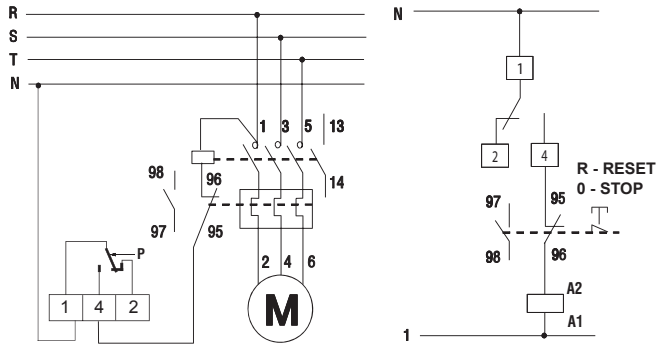

Nominal insulation tension	Ui 415V~	
Continuous duty nominal current	Ith 16A	
Operating nominal current Ie	220V-	380/415V~
Resistive load	AC-1	- 16A
Inductive load	AC-3	- 6A
Continuous current	DC-13	0,2A

HOMOLOGATION AND STANDARDS

Complies with EN 60947-1 and 60947-5-1 standards.



INSTALLATION

Direct installation on the pipe.
 Pressure element connection G 1/4.
 In case of fluid temperatures higher than the maximum allowed, connect the pressure switch to the pipe by inserting a metallic spiral between the pressure switch and the pipe to facilitate heat dispersion.
 Possibility of mounting on metallic clamp, except for the waterproof casing versions.

MOUNTING MODEL

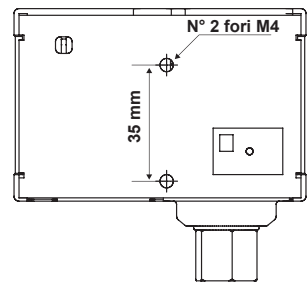

OPERATION

When pressure increases: 1-2 opens, 1-4 closes.
 In the pressure switch with blocking and manual reset at maximum pressure, the reset takes place when the pressure is below the value set on differential.

FEATURES

- Sensitive element with stainless steel membrane, laser welded.
- Metallic frame.
- Cover in shockproof thermoplastic material.
- Output connections with PVC cable gland.
- Female connection G 1/4 (17 mm key).
- Maximum temperature of the controlled fluid: 120 °C.
- Pressure switch body admissible temperature: -35 ÷ 60°C.
- Storage and transport temperature: -35 ÷ 60°C.
- Unit weight: 0,43 Kg B12AN.
- Unit weight: 0,44 Kg B12BN.

ACCESSORIES



303298LA
 G1/2 cable gland in V0 self-extinguishing, shockproof thermoplastic material for output connections.

2593367
 Protection casing IP44.

B12CN - B12DN - B12EN

Pressure switches up to 28 bar with adjustable differential

Pressure switches for control and regulation of all fluids and non-explosive gases. Suitable for compression plants, boilers, tanks, autoclaves, ventilation plants, lubrication plants.

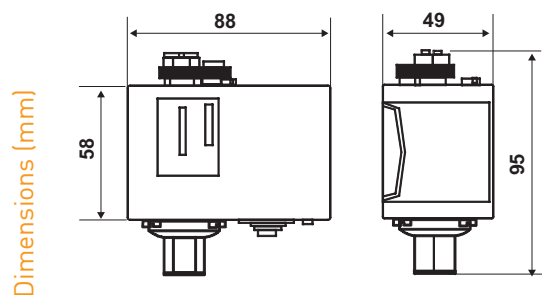

	Range bar	Differential* bar	Sensitive element max. pressure bar	Connection G 1/4	Protection degree	Availability
B12CN	-0,2 ÷ 8	0,6 ÷ 3	9	female	IP40	in stock
B12DN	5 ÷ 16	1 ÷ 3,5	18	female	IP40	in stock
B12EN	8 ÷ 28	2 ÷ 6	32	female	IP40	in stock
B12CRN	-0,2 ÷ 8	0,6 ÷ 3	9	SAE	IP40	in stock
B12ERN	8 ÷ 28	2 ÷ 6	32	SAE	IP40	in stock
B12CN4	-0,2 ÷ 8	0,6 ÷ 3	9	male	IP40	on request
B12DN4	5 ÷ 16	1 ÷ 3,5	18	male	IP40	on request

WITH BLOCKING AND MANUAL RESET

B12CMN	1 ÷ 8	0,6 ÷ 3	9	female	IP40	on request
B12DMN	5 ÷ 16	1 ÷ 3,5	18	female	IP40	on request
B12EMN	8 ÷ 28	2 ÷ 6	32	female	IP40	on request

WATERPROOF CASING EXECUTION

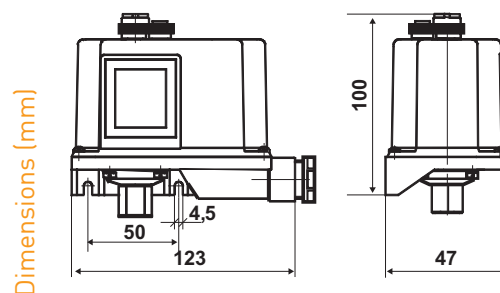

	Range bar	Differential* bar	Sensitive element max. pressure bar	Connection G 1/4	Protection degree	Availability
B12CNY	-0,2 ÷ 8	0,6 ÷ 3	9	female	IP65	in stock
B12DNY	5 ÷ 16	1 ÷ 3,5	18	female	IP65	in stock
B12ENY	8 ÷ 28	2 ÷ 6	32	female	IP65	in stock
B12CRNY	-0,2 ÷ 8	0,6 ÷ 3	9	SAE	IP65	in stock
B12ERNY	8 ÷ 28	2 ÷ 6	32	SAE	IP65	in stock

1 Bar = 100Kpa *The differential must be deducted from the range value.

ELECTRICAL FEATURES

Snap action SPDT microswitch, contacts in AgCdO.

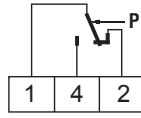

EXAMPLE OF ELECTRICAL WIRING

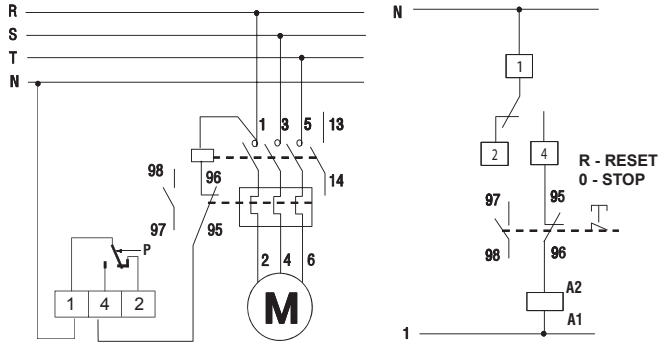

Nominal insulation tension	Ui	415V~	
Continuous duty nominal current	Ith	16A	
Operating nominal current le		220V~	380/415V~
Resistive load	AC-1	-	16A
Inductive load	AC-3	-	6A
Continuous current	DC-13	0,2A	-

HOMOLOGATION AND STANDARDS

Complies with EN 60947-1 and 60947-5-1 standards.

CE 0497

INSTALLATION

Direct installation on the pipe.

Pressure element connection G 1/4.

In case of fluid temperatures higher than the maximum allowed, connect the pressure switch to the pipe by inserting a metallic spiral between the pressure switch and the pipe to facilitate heat dispersion.

Possibility of mounting on metallic clamp, except for the waterproof casing versions.

MOUNTING MODEL

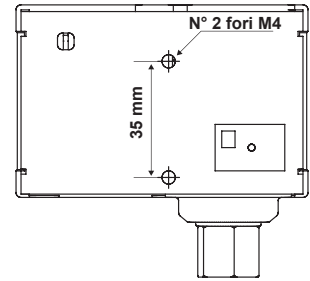

OPERATION

When pressure increases: 1-2 opens, 1-4 closes.

In the pressure switch with blocking and manual reset at maximum pressure, the reset takes place when the pressure is below the value set on differential.

FEATURES

Sensitive element with stainless steel membrane, laser welded.

Metallic frame.

Cover in shockproof thermoplastic material.

Output connections with PVC cable gland.

Fixed differential.

Female connection G 1/4 (17 mm key).

Maximum temperature of the controlled fluid: 120 °C.

Pressure switch body admissible temperature: -35 ÷ 60°C.

Storage and transport temperature: -35 ÷ 60°C.

Unit weight: 0,43 Kg B12AN.

Unit weight: 0,44 Kg B12BN.

ACCESSORIES



303298LA

G1/2 cable gland in V0 self-extinguishing, shockproof thermoplastic material for output connections.



2593367

Protection casing IP44.