

148R9540

148R9540

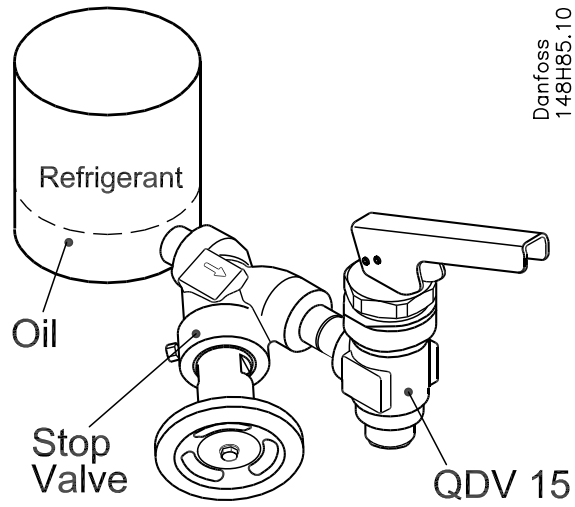

Fig. 1

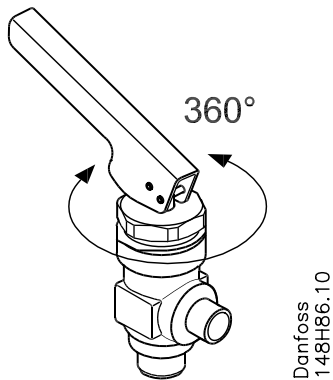

Fig. 2

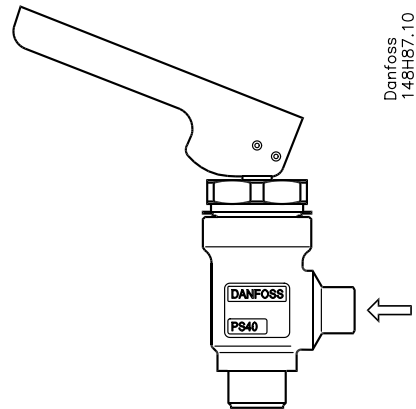

Fig. 3

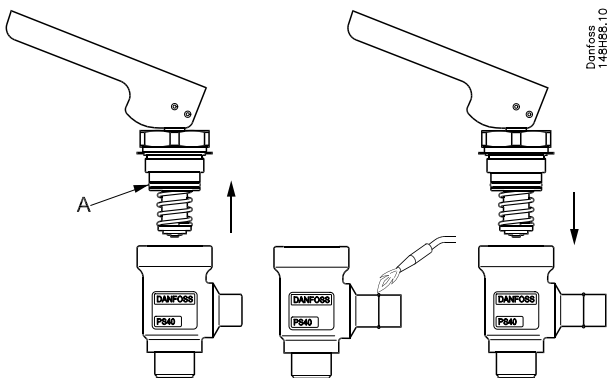

Fig. 4

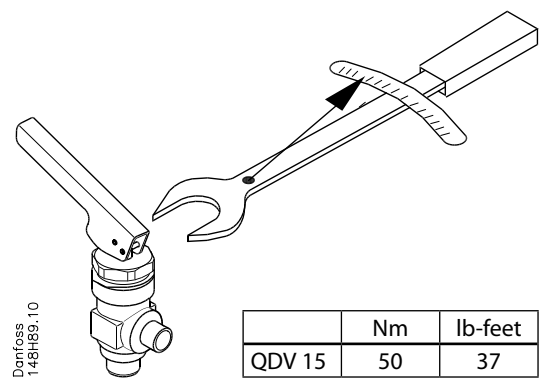

Fig. 5

Refrigerants:

Applicable to all common non-flammable refrigerants, including R717 and non corrosive gases/liquids depending on sealing material compatibility.

Flammable hydrocarbons are not recommended. The valve is only recommended for use in closed circuits. For further information please contact Danfoss.

Temperature range:

QDV 15: -50/+150°C (-58/+302°F)

Pressure range:

The valves are designed for a max. working pressure of 40 bar g (580 psi g). In order to prevent hydraulic pressure building up between the stop valve and the QDV an integral relief device is included opening the valve slowly if the pressure exceeds 25 bar g (363 psi g).

Installation:

The valve must be installed after a stop valve with the spindle vertically upwards and with flow direction from the side branch (fig. 1).



If any tube or hose is mounted on the outlet of the QDV it has to be calculated to prevent backpressure building up when relieving. Blocking the outlet of the QDV will cause danger (hydraulic pressure building up).

The handle can be turned 360° for optimizing operation position (fig. 2). Valves should only be operated by hand without the use of tools or other devices. The valve is designed to withstand a high internal pressure. However, the piping system should be designed to avoid liquid traps and reduce the risk of hydraulic pressure caused by thermal expansion. It must be ensured that the valve is protected from pressure transients like "liquid hammer" in the system.

Recommended flow direction:

The valve must be installed with flow direction from the side branch (fig. 3).

Welding:

The bonnet should be removed before welding (fig. 4) to prevent damage to the O-ring between the valve body and bonnet, as well as the Teflon cone ring in the valve seat.

Only materials and welding methods, compatible with the valve housing material, must be welded to the valve housing.

The valve should be cleaned internally to remove welding debris on completion of welding and before the valve is reassembled.

Avoid welding debris and dirt in the threads of the housing and the bonnet.

Removing the bonnet can be omitted provided that:

The temperature in the area between the valve body and bonnet during welding does not exceed +150°C/+302°F.

This temperature depends on the welding method as well as on any cooling of the valve body during the welding itself.

(Cooling can be ensured by, for example, wrapping a wet cloth around the valve body.) Make sure that no dirt, welding debris etc. get into the valve during the welding procedure.

Be careful not to damage the Teflon cone ring. The valve housing must be free from stresses (external loads) after installation.

Assembly:

Remove welding debris and any dirt from pipes and valve body before assembly. Check that the O-ring between the valve body and bonnet, as well as the Teflon cone ring in the valve seat is without marks or scratches.

Tightening:

Tighten the bonnet with a torque wrench, to the values indicated in the table (fig. 5).

Colors and identification:

The QDV 15 valves are painted with a red oxide primer in the factory. Precise identification of the valve is made via the ID ring at the top of the bonnet, as well as by the stamping on the valve body. The external surface of the valve housing must be prevented against corrosion with a suitable protective coating after installation and assembly. Protection of the ID ring when repainting the valve is recommended.

Maintenance

Dismantling the valve (fig. 4):

Do not remove the bonnet while the valve is still under pressure. Always close the stop valve before the QDV. Then proceed with activation of the QDV valve to make sure that it is not under pressure.

- Check that the O-ring (pos. A) has not been damaged.
- Check that the spindle is free of scratches and impact marks.
- Check that the Teflon cone ring is without marks or scratches.

Replacement of the O-ring between the bonnet and the valve body (fig. 4):

The QDV 15 is delivered with an extra O-ring. Remove the damaged O-ring (pos. A) from the bonnet and carefully install the new O-ring.

Assembly:

Remove any dirt from the body before the valve is assembled.

Check that the O-ring between the valve body and bonnet, as well as the Teflon gasket in the valve seat is without marks or scratches.

Tightening:

Tighten the bonnet with a torque wrench, to the values indicated in the table (fig. 5).

Use only original Danfoss parts for replacement.

New parts must be made of certified materials applicable for the refrigerant used.

In cases of doubt, please contact Danfoss.

Danfoss accepts no responsibility for errors and omissions.

Danfoss Industrial Refrigeration reserves the right to make changes to products and specifications without prior notice.

DECLARATION OF CONFORMITY
The Pressure Equipment Directive 97/23/EC



Name and Address of Manufacturer within the European Community

Danfoss Industrial Refrigeration A/S
Stormosevej 10
PO Box 60
DK-8361 Hasselager
Denmark

Declaration

We hereby declare that below mentioned equipment are Classified for Fluid Group I (all refrigerants (toxic, non-toxic, flammable and non-flammable)), and that all are covered by Article 3, paragraph 3.

For further details / restrictions - see Installation Instruction

Description of Pressure Equipment

Refrigerant Quick Drain Valve for oil
Type **QDV 15**

Nominal bore **DN ≤ 25 mm** (1 in.)

References of Technical Standards and Specifications used

EN 12284 DIN 3158
AD-Merkblätter 2000

Authorised Person for the Manufacturer within the European Community

Name: Michael Breumsø **Title:** Production Manager

Signature:  **Date:** 01/09/2005