

Installation



Note:
At delivery the filter housing is not equipped with filter element or accessories.

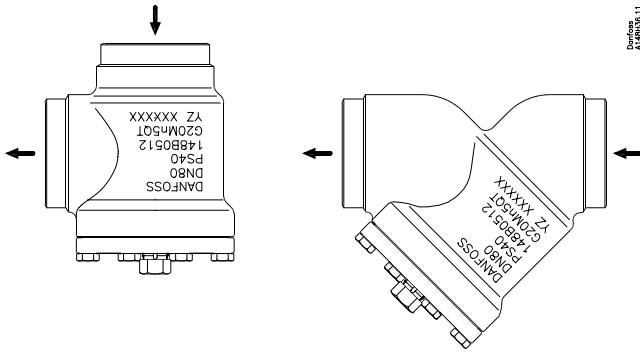

fig. 1

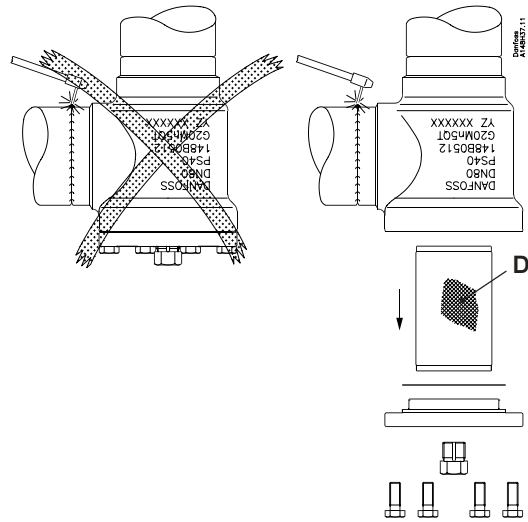

fig. 2

Maintenance

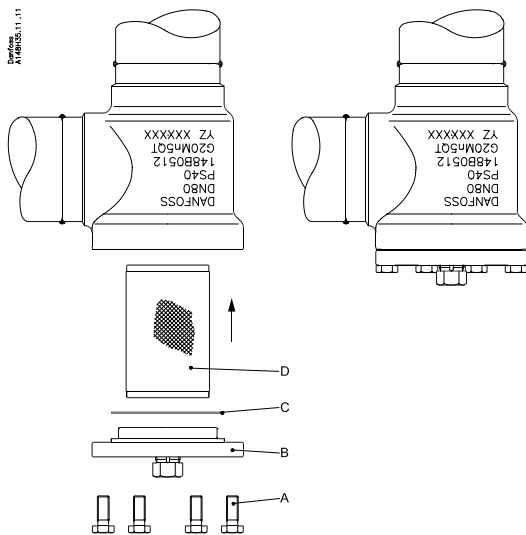

fig. 3

	Nm	LB-feet
DN 15-20-25-32-40	22	16
DN 50	44	32
DN 65	75	53
DN 80	44	32
DN 100	75	53
DN 125-150	183	135
DN 200	370	272



Filter bag
Flow direction:

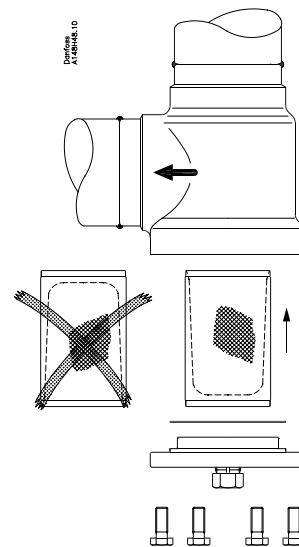

fig. 4

Installation

Refrigerants

Applicable to all common refrigerants, including R717 and non-corrosive gases/liquids dependent on sealing material compatibility.

The filter is only recommended for use in closed circuits. For further information please contact Danfoss.

Temperature range

FIA 15-200: $-60/+150^{\circ}\text{C}$ ($-76/+302^{\circ}\text{F}$)

FIA-SS 15-40: $-60/+150^{\circ}\text{C}$ ($-76/+302^{\circ}\text{F}$)

Pressure range

FIA 15-200: The filters are designed for a max. working pressure of 40 bar g (580 psi g).

Installation**Note:**

At delivery the filter housing is not equipped with filter element or accessories

The filter must be installed with the top cover downwards, and the flow must be directed towards the top cover as indicated by the arrow on the filter housing (fig. 1). The filter element must be inserted after welding.

The filter is designed to withstand a high internal pressure. However, the piping system should be designed to avoid liquid traps and reduce the risk of hydraulic pressure caused by thermal expansion. It must be ensured that the filter is protected from pressure transients like "liquid hammer" in the system.

Recommended flow direction

The filter must be installed with the flow towards the top cover as indicated by the arrow on the side of the valve body (fig. 1). Flow in the opposite direction is not acceptable.

Welding

The top cover should be removed before welding (fig. 2) to prevent damage to the gasket between the filter body and top cover. Only materials and welding methods, compatible with the valve housing material, must be welded to the valve housing. The filter should be cleaned internally to remove welding debris on completion of welding and before the valve is reassembled.

Removing the top cover can be omitted provided that:

The temperature in the area between the valve body and top cover during welding does not exceed $+150^{\circ}\text{C}/+302^{\circ}\text{F}$. This temperature depends on the welding method as well as on any cooling of the filter body during the welding itself.

(Cooling can be ensured by, for example, wrapping a wet cloth around

the filter body.) Make sure that no dirt, welding debris etc. get into the filter during the welding procedure.

The filter housing must be free from stresses (external loads) after installation.

Filters must not be mounted in systems where the outlet side of the filter is open to atmosphere. The outlet side of the filter must always be connected to the system or properly capped off, for example with a welded-on end plate.

Assembly

Remove welding debris and any dirt from pipes and filter body before assembly. Check that the filter element has the right size before it is inserted in the top cover. And check that there is no damage on the gasket.

Place the filter element (pos. D) from underneath. The element has a slight force fit into the housing, no gaskets or O-rings are used.

If magnets have been chosen as accessory, these should be fitted on the top cover before replacing the cover.

Tightening

Tighten the top cover with a torque wrench, to the values indicated in the table (fig. 3).

If the drain valve has been chosen as accessory, the drain plug should be replaced by the drain valve.

Colours and identification

The FIA valves are painted with a red oxide primer in the factory. Stainless steel valves are not painted. Precise identification of the valve is made via the ID plate on the top cover, as well as by the stamping on the valve body. The external surface of the valve housing must be prevented against corrosion with a suitable protective coating after installation and assembly.

Protection of the ID plate when repainting the valve is recommended.

Maintenance

Mounting of accessory:**Filter bag (fig. 4)**

A 50μ filter bag (pos. E), especially for commissioning of the plant, can replace the normal filter element.

When mounting the filter bag, which is held in place by a filter holder, the utmost care must be taken to place the filter bag correctly in the filter as shown in fig. 4.

The flow must go into the filter bag cavity and out or else the bag will not function properly.

Above described function will only be valid depending that the proper flow direction of the filter valve has been used.

Dismantling the valve (fig. 3)

Before servicing the filter valves, isolate it from the system and remove all refrigerant by evacuation to zero pressure. Check for refrigerant pressure before unscrewing and removal of the top cover.

The filter element should be removed without any use of tools

Cleaning

Clean the filter element using an appropriate solvent by flushing and brushing. The use of strong acids cannot be recommended. The filter element should be wiped or blown dry before inspection. If the element is damaged or the sediments cannot be removed, the filter element should be replaced.

Assembly

Remove any dirt from the body before the valve is assembled.

Replacement of gasket

It is recommended to always change the gasket for the top cover (pos. C) and drain plug.

Check that the filter element is correctly placed before remounting the top cover and bolts (pos. A).

Tightening (fig. 3)

Tighten the top cover bolts (pos. A) with a torque wrench according to the table in fig. 3

Use only original Danfoss parts, including gaskets for replacement. Materials of new parts are certified for the relevant refrigerant.

In cases of doubt, please contact Danfoss.

Danfoss accepts no responsibility for errors and omissions. Danfoss Industrial Refrigeration reserves the right to make changes to products and specifications without prior notice.

