

Fig. 1, SCH 50-100

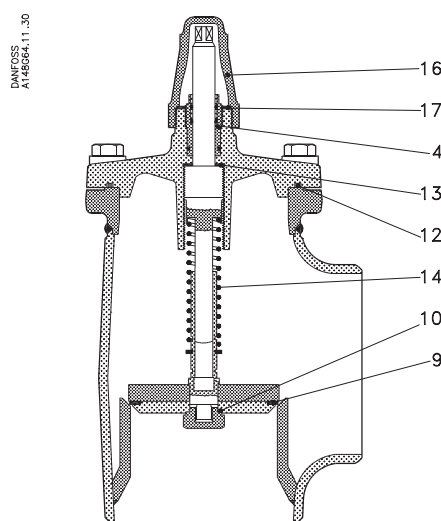

Fig. 2, SCH 125-200

Description	Type	Size 40-50	Size 65-80	Size 100	Size 125	Size 150	Size 200
		(1 1/2 - 2 in.)	(2 1/2-3 in.)	(4 in.)	(5 in.)	(6 in.)	(8 in.)
		Code no.	Code no.	Code no.	Code no.	Code no.	Code no.
Spare part kit , for bonnet and cap (dismounting set)	all	148B4081	148B4082	148B4083	148B4084	148B4085	148B4085
Pos. 12 O-ring/gasket (only for size 125) for housing/bonnet							
17 Gasket for cap							
Repair kit , complete set of gaskets	all	3184+112	3184+113	3184+114	3184+115	3184+116	3184+116
Pos. 4a Gaskets complete for packing gland							
9 Gasket for cone							
10 Gasket for cone							
12 O-ring/gasket (only for size 125) for housing/bonnet							
13 Back sealing							
17 Gasket for cap							
Packing gland incl. gaskets (with O-rings)	all	148B4087	148B4088	148B4088	148B4088	148B4089	148B4089
Pos. 4 Packing gland incl. gaskets							
Spring – standard ($\Delta p = 0.05$ bar)	XX3	148G3208	148G3209	148G3210	148G3211	148G3212	148G3212
Pos. 14 Spring							
Spring – special ($\Delta p = 0.3$ bar)	XX9	148G3213	148G3214	148G3215	148G3216	148G3217	148G3217
Pos. 14 Spring							
Cap incl. gasket	-	148B4100	148B4101	148B4101	148B4101	148B4102	148B4102
Pos. 16 Cap incl. gasket							
Top without spring*		148G3493	148G3494	148G3495	148G3496	148G3497	148G3498
Grease for packing gland (tube)	-	2452+143	2452+143	2452+143	2452+143	2452+143	2452+143
0.05 bar g = 0.73 psi g							
0.3 bar g = 4.35 psi g							
Note: Type XX1 and XX2, produced from 1994							
* Top: complete valve without housing							