



### Media: HFC and HCFC refrigerants, oil, air, water

Medium: Kältemittel HFCKW und HFKW, Öl, Luft, Wasser  
 Médias: HFC et HCFC, huile, air, eau  
 Aplicaciones: Refrigerantes fluorinados HFC/HCFC, aceite, aire, agua  
 Mezzo: HFC e HCFC refrigeranti, olio, aria, acqua

Type	Contact system	Ohmic	Inductive FLA	Starting LRA	Voltage
ACB-1UA	SPST-NO	1A	1A	6A	240 AC
ACB-1UB	SPST-NC	1A	1A	6A	240 AC
ACB-2UA	SPST-NO	6A	6A	36A	240 AC
ACB-2UB	SPST-NC	6A	6A	36A	240 AC
ACB-4UA	SPST-NO	0,05A	-	-	24 AC
ACB-4UB	SPST-NC	0,05A	-	-	24 AC
ACB-2UC	SPDT 	4A	4A	24A	250 AC
ACB-2UC	SPDT 	8A	8A	48A	240 AC

### Min/Max Temperature

Min/Max Temperatur  
 Min/Max Température  
 Min/Max Temperatura  
 Min/Max Temperatura

Ambient:  
 Umgebung:  
 Ambiente:  
 Ambiente:  
 Ambiente:  
 -30 → +85 °C  
 -20 → +185°F

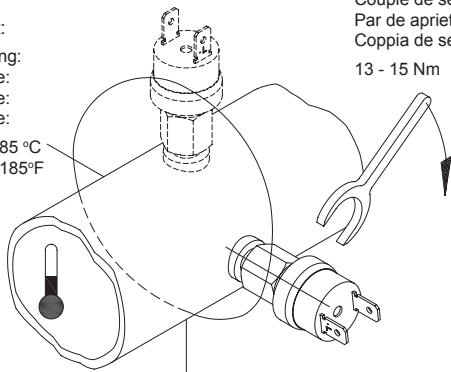

Torque:  
 Moment:  
 Couple de serrage:  
 Par de apriete:  
 Coppia de serraggio:  
 13 - 15 Nm

Media:  
 Medium:  
 Médias:  
 Aplicaciones:  
 Mezzo:  
 -55 → +135°C  
 -70 → +275°C

### Soldering

Löten  
 Soudage  
 Saldatura  
 Soldadura

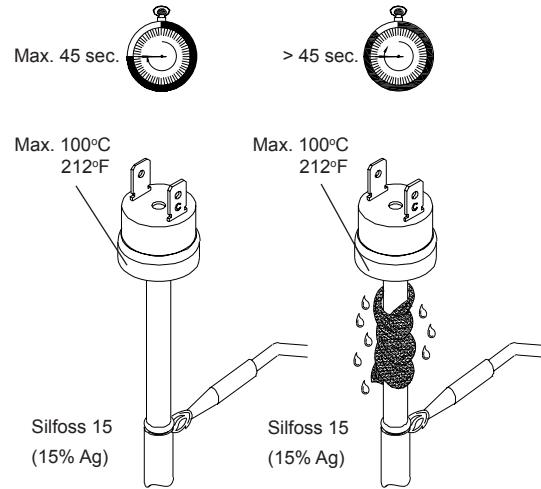

### Contact system

Kontaktsystem  
 Système de contacts  
 Contactos eléctricos  
 Tipo di contatti

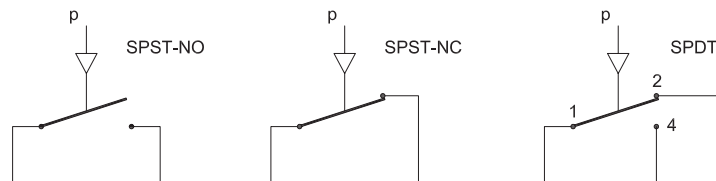

1: Red    4: Blue    2: Black  
 1: Rot    4: Blau    2: Schwarz  
 1: Rouge    4: Bleu    2: Noir  
 1: Rojo    4: Azul    2: Negro  
 1: Rosso    4: Blue    2: Nero