

General Danfoss flange sets inclusive of gaskets, bolts and nuts, are specially made for the Danfoss product range and must only be used for the purpose described. Flanges for Danfoss automatic controls for refrigeration plant are made of steel or brass.

Tongue or groove single flanges version 1 Tongue flanges are used for **TE 12, TEA 20, TEAT 20, TEVA 20, EVR 15, EVRA 3, EVRA 10, EVRA 15, NRVA 15, NRVA 20, CVM, CVM(M), CVML, CVMH, CVMO, CVMP, CVMT, CVK, CVKP, CVMQ.** Each code no. includes one flange and one flange gasket. Separate flange gaskets, ID 22 x OD 32 x 1.0 mm (ID 0.866 x OD 1.260 x 0.039 in.): **Code no. 020-2133** (40 pcs.) must be ordered separately.

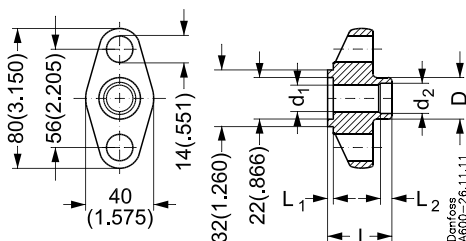

Tongue flange

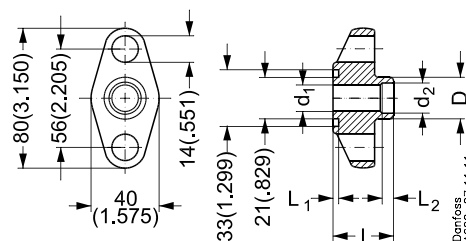

Groove flange

Butt welding DIN (2448)

Tongue flanges:

Size mm	Size in.	D mm	D in.	d ₁ mm	d ₁ in.	d ₂ mm	d ₂ in.	L mm	L in.	L ₁ mm	L ₁ in.	L ₂ mm	L ₂ in.	Code no.
6	1/4	14	0.551	8	0.315	10	0.394	32.5	1.279	3	0.118	6	0.236	006-1118
10	3/8	18	0.709	10	0.394	14	0.551	32.5	1.279	3	0.118	6	0.236	006-1120
15	1/2	22	0.866	14	0.551	17	0.669	32.5	1.279	3	0.118	6	0.236	006-1122
20	3/4	27	1.063	19	0.748	22	0.866	32.5	1.279	3	0.118	6	0.236	006-1124

Butt welding DIN (2448)

Groove flanges:

Size mm	Size in.	D mm	D in.	d ₁ mm	d ₁ in.	d ₂ mm	d ₂ in.	L mm	L in.	L ₁ mm	L ₁ in.	L ₂ mm	L ₂ in.	Code no.
6	1/4	14	0.551	8	0.315	10	0.394	32.5	1.279	2	0.079	6	0.236	006-1119
10	3/8	18	0.709	10	0.394	14	0.551	32.5	1.279	2	0.079	6	0.236	006-1121
15	1/2	22	0.866	14	0.551	17	0.669	32.5	1.279	2	0.079	6	0.236	006-1123
20	3/4	27	1.063	19	0.748	22	0.866	32.5	1.279	2	0.079	6	0.236	006-1125

Soldering DIN (2856)

Tongue flanges:

Size mm	D mm	D in.	d ₁ mm	d ₁ in.	d ₂ mm	d ₂ in.	L mm	L in.	L ₁ mm	L ₁ in.	L ₂ mm	L ₂ in.	Code no.
12	17	0.669	10	0.394	12	0.472	29.5	1.161	3	0.118	15	0.590	006-1181
16	21	0.827	13	0.512	16	0.630	29.5	1.161	3	0.118	15	0.590	006-1182
25	30	1.181	18	0.709	25	0.984	29.5	1.161	3	0.118	22	0.866	006-1183

Soldering ANSI (B 16.22)

Tongue flanges:

Size in.	D mm	D in.	d ₁ mm	d ₁ in.	d ₂ mm	d ₂ in.	L mm	L in.	L ₁ mm	L ₁ in.	L ₂ mm	L ₂ in.	Code no.
1/2	17	0.669	10	0.394	12.7	0.500	29.5	1.161	3	0.118	17.5	0.689	006-1160
5/8	21	0.827	13	0.512	15.9	0.626	29.5	1.161	3	0.118	20.5	0.807	006-1162
3/4	24	0.945	16	0.630	19.0	0.748	29.5	1.161	3	0.118	22	0.866	006-1164
7/8	27	1.063	19	0.748	22.2	0.874	29.5	1.161	3	0.118	22	0.866	006-1176
1	30	1.181	18	0.709	25.5	1.004	29.5	1.161	3	0.118	22	0.866	006-1166

Soldering ANSI (B 16.22)

Groove flanges:

Size in.	D mm	D in.	d ₁ mm	d ₁ in.	d ₂ mm	d ₂ in.	L mm	L in.	L ₁ mm	L ₁ in.	L ₂ mm	L ₂ in.	Code no.
1/2	17	0.669	10	0.394	12.7	0.500	26.5	1.043	3	0.118	17.5	0.689	006-1161
5/8	21	0.827	13	0.512	15.9	0.626	26.5	1.043	3	0.118	20.5	0.807	006-1163
3/4	24	0.945	16	0.630	19.0	0.748	26.5	1.043	3	0.118	20.5	0.807	006-1165
7/8	27	1.063	18	0.709	22.2	0.874	26.5	1.043	3	0.118	22	0.866	006-1177
1	30	1.181	18	0.709	25.5	1.004	26.5	1.043	3	0.118	20.5	0.807	006-1167

Tongue/groove flange sets version 1.1

 Used for
FA 15

Each code no. includes two flanges, two flange gaskets, two staybolts, and four nuts.

 Flange dimensions:
 See table for single flanges.

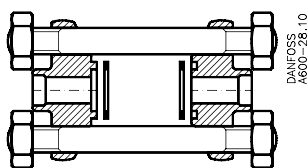
 Separate flange gaskets,
 ID 22 × OD 32 × 1.0 mm
 (ID 0.866 × OD 1.260 × 0.039 in.);
Code no. 020-2133 (40 pcs.) must be ordered separately.

Butt welding DIN (2448)
 Tongue/groove flange sets:

Size mm	Size in.	Staybolt	Nut	Code no.
6	1/4	M 12 × 127 mm	M 12	006-1110
10	3/8	M 12 × 127 mm	M 12	006-1111
15	1/2	M 12 × 127 mm	M 12	006-1112
20	3/4	M 12 × 127 mm	M 12	006-1113

Soldering ANSI (B 16.22)
 Tongue/groove flange sets:

Size mm	Size in.	Staybolt	Nut	Code no.
15	1/4	M 12 × 127 mm	M 12	006-1150
16	3/8	M 12 × 127 mm	M 12	006-1151
20	1/2	M 12 × 127 mm	M 12	006-1152
22	3/4	M 12 × 127 mm	M 12	006-1158
25	1	M 12 × 127 mm	M 12	006-1153

Tongue/tongue flange sets version 1.2

 Used for
TE 12, TEA 20, TEAT 20, TEVA 20, EVR 15, EVRA 3, EVRA 10, EVRA 15, NRVA 15, NRVA 20, CVM, CVM(M), CVML, CVMH, CVMO, CVMP, CVMT, CVK, CVKP, CVMQ

Each code no. includes two flanges, two flange gaskets, two staybolts, and four nuts.

 Separate flange gaskets,
 ID 22 × OD 32 × 1.0 mm
 (ID 0.866 × OD 1.260 × 0.039 in.);
Code no. 020-2133 (40 pcs.)

 Flange dimensions:
 See drawing for single flanges.

Butt welding DIN (2448)
 Tongue flange sets:

Size mm	Staybolt	Nut	Code no.
15 × 15	M 12 × 135 mm	M 12	27B0181

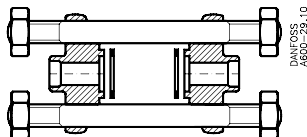
Soldering ANSI (B 16.22)
 Tongue/groove flange sets:

Size mm	Size in.	Staybolt	Nut	Code no.
	5/8 × 7/8	M 12 × 127 mm	M 12	006-1195
	3/8 × 1	M 12 × 127 mm	M 12	006-1196
	1/2 × 1/2	M 12 × 135 mm	M 12	027B0180
16 × 22		M 12 × 127 mm	M 12	006-1197
22 × 252		M 12 × 127 mm	M 12	006-1198
12 × 12		M 12 × 135 mm	M 12	027B0182

Tongue/tongue flange sets version 1.3

Used for
TE 12, TEA 20, TEAT 20, TEVA 20,
EVR 15, EVRA 3, EVRA 10, EVRA 15,
NRVA 15, NRVA 20,
CVM, CVM(M), CVML, CVMH, CVMO,
CVMP, CVMT, CVK, CVKP, CVMQ

Each code no. includes two flanges.

Separate flange gaskets,
 ID 22 × OD 32 × 1.0 mm
 (ID 0.866 × OD 1.260 × 0.039 in.):
Code no. 020-2133 (40 pcs.) must be ordered
 separately.

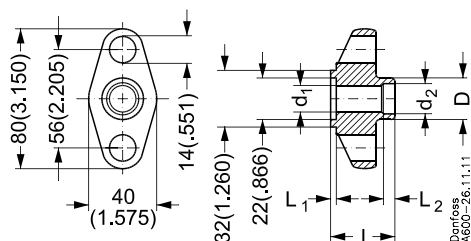

Butt welding DIN (2448)

Tongue flange sets:

Size mm	Size in.	D mm	D in.	d ₁ mm	d ₁ in.	d ₂ mm	d ₂ in.	L mm	L in.	L ₁ mm	L ₁ in.	L ₂ mm	L ₂ in.	Code no.
10	3/8	18	0.709	10	0.394	14	0.551	32.5	1.280	3	0.118	6	0.236	027N1112
15	1/2	22	0.866	14	0.551	17	0.669	32.5	1.280	3	0.118	6	0.236	027N1115
20	3/4	27	1.063	19	0.748	22	0.866	32.5	1.280	3	0.118	6	0.236	027N1120

Butt welding ANSI B 36.10

Tongue flange sets:

Size mm	Size in.	D mm	D in.	d ₁ mm	d ₁ in.	d ₂ mm	d ₂ in.	L mm	L in.	L ₁ mm	L ₁ in.	L ₂ mm	L ₂ in.	Code no.
10	3/8	17.1	0.673	10.7	0.421	10.7	0.421	32.5	1.280	3	0.118	6	0.236	027N2020
15	1/2	21.3	0.839	13.9	0.547	13.9	0.547	32.5	1.280	3	0.118	6	0.236	027N2021
20	3/4	26.9	1.059	18.9	0.744	18.9	0.744	32.5	1.280	3	0.118	6	0.236	027N2022

Socket welding ANSI (B 16.11)

Tongue flange sets:

Size mm	Size in.	D mm	D in.	d ₁ mm	d ₁ in.	d ₂ mm	d ₂ in.	L mm	L in.	L ₁ mm	L ₁ in.	L ₂ mm	L ₂ in.	Code no.
10	3/8	26	1.024	12.5	0.492	17.8	0.701	32.5	1.280	3	0.118	10	0.394	027N2010
15	1/2	31.6	1.244	15.8	0.622	22	0.866	32.5	1.280	3	0.118	10	0.394	027N2011

FPT inside thread, NPT (ANSI/ASME B 1.20.1)

Tongue flange sets:

Size mm	Size in.	D mm	D in.	d ₁ mm	d ₁ in.	d ₂ mm	d ₂ in.	L mm	L in.	L ₁ mm	L ₁ in.	L ₂ mm	L ₂ in.	Code no.
10	3/8	26	1.024	14.3	0.563	3/8"-18 NPT	3/8"-18 NPT	32.5	1.477	3	0.118			027G1005
15	1/2	31.6	1.244	17.8	0.701	1/2"-14 NPT	1/2"-14 NPT	32.5	1.280	3	0.118			027G1006

Soldering DIN (2856)

Tongue flange sets:

Size mm	D mm	D in.	d ₁ mm	d ₁ in.	d ₂ mm	d ₂ in.	L mm	L in.	L ₁ mm	L ₁ in.	L ₂ mm	L ₂ in.	Code no.
16	21	0.827	13	0.512	16	0.630	29.5	2.122	3	0.118	15	0.591	027L1116
22	27	1.063	19	0.748	22.1	0.869	29.5	1.161	3	0.118	22	0.866	027L1122

Soldering ANSI (B 16.22)

Tongue flange sets:

Size in.	D mm	D in.	d ₁ mm	d ₁ in.	d ₂ mm	d ₂ in.	L mm	L in.	L ₁ mm	L ₁ in.	L ₂ mm	L ₂ in.	Code no.
5/8	21	0.827	13	0.512	15.9	0.626	29.5	1.161	3	0.118	20.5	0.807	027L1117
7/8	27	1.063	19	0.748	22.2	0.874	29.5	1.161	3	0.118	22	0.866	027L1123

Tongue/groove flange sets version 1.4

Used for
FA 15

Each code no. includes two flanges.

Flange dimensions:
See drawing for single flanges.

Separate flange gaskets,
ID 21 x OD 33 x 1.0 mm
(ID 0.827 x OD 1.299 x 0.039 in.):
Code no. 020-2133 (40 pcs.) must be ordered separately.

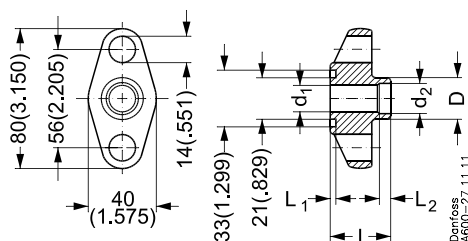

Butt welding DIN (2448)

Tongue/groove flange set:

Size mm	Size in.	D mm	D in.	d ₁ mm	d ₁ in.	d ₂ mm	d ₂ in.	L mm	L in.	L ₁ mm	L ₁ in.	L ₂ mm	L ₂ in.	Code no.
10	3/8	18	0.709	10	0.394	14	0.551	32.5	1.279	3	0.118	6	0.236	027N1512

Tongue or groove single flanges version 2

Tongue flanges are used for
PHT 85, PHTQ 85

Each code no. includes one flange and one flange gasket.

One tongue flange and one groove flange are used for
FA 20 and EVSA 25.

Separate flange gaskets,
ID 32 x OD 43.8 x 1.5 mm
(ID 1.260 x OD 1.724 x 0.059 in.):
Code no. 011L8101 (40 pcs.)

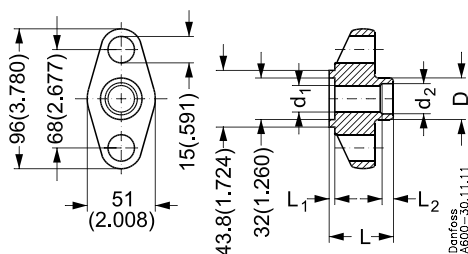

Tongue flange

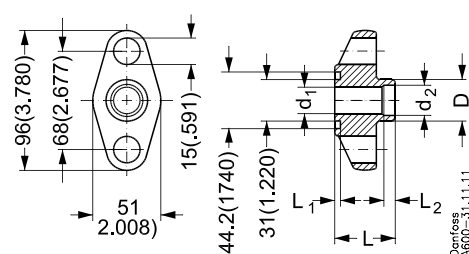

Groove flange

Butt welding DIN (2448)

Tongue flanges:

Size mm	Size in.	D mm	D in.	d ₁ mm	d ₁ in.	d ₂ mm	d ₂ in.	L mm	L in.	L ₁ mm	L ₁ in.	L ₂ mm	L ₂ in.	Code no.
10	1/2	22	0.866	14	0.551	17	0.669	35	1.378	3	0.118	6	0.236	006-1126
20	3/4	27	1.063	19	0.748	22	0.866	35	1.378	3	0.118	6	0.236	006-1128
25	1	34	1.338	26	1.024	18	1.102	37.5	1.476	3	0.118	6	0.236	006-1130

Butt welding DIN (2448)

Groove flanges:

Size mm	Size in.	D mm	D in.	d ₁ mm	d ₁ in.	d ₂ mm	d ₂ in.	L mm	L in.	L ₁ mm	L ₁ in.	L ₂ mm	L ₂ in.	Code no.
15	1/2	22	0.866	14	0.551	17	0.669	34.5	1.358	3	0.118	6	0.236	006-1127
20	3/4	27	1.063	19	0.748	22	0.866	34.5	1.358	3	0.118	6	0.236	006-1129
25	1	34	1.338	26	1.024	18	1.102	34.5	1.358	3	0.118	6	0.236	006-1131

Continued on next page

Tongue or groove single flanges

version 2

(continued)

Soldering DIN (2856)

Tongue/groove flanges:

Size mm	D mm	D in.	d ₁ mm	d ₁ in.	d ₂ mm	d ₂ in.	L mm	L in.	L ₁ mm	L ₁ in.	L ₂ mm	L ₂ in.	Code no.
22	27	1.063	19	0.748	22	0.866	30	1.181	3	0.118	22	0.866	006-1179*
22	27	1.063	19	0.748	22	0.866	30	1.181	3	0.118	22	0.866	006-1178**

* Groove

** Tongue

Soldering ANSI (B 16.22)

Tongue flanges:

Size in.	D mm	D in.	d ₁ mm	d ₁ in.	d ₂ mm	d ₂ in.	L mm	L in.	L ₁ mm	L ₁ in.	L ₂ mm	L ₂ in.	Code no.
5/8	21	0.827	13	0.512	15.9	0.626	33	1.299	3	0.118	20.5	0.807	006-1168
3/4	24	0.945	16	0.630	19	0.748	33	1.299	3	0.118	25	0.984	006-1170
1	30	1.181	22	0.866	25.5	1.004	33	1.299	3	0.118	25	0.984	006-1172
1 1/8	34	1.338	26	1.024	28.6	1.126	33	1.299	3	0.118	26	1.024	006-1174
1 1/8	34	1.338	26	1.024	28.6	1.126	30	1.181	3	0.118	26	1.024	006-1175

Soldering ANSI (B 16.22)

Groove flanges:

Size in.	D mm	D in.	d ₁ mm	d ₁ in.	d ₂ mm	d ₂ in.	L mm	L in.	L ₁ mm	L ₁ in.	L ₂ mm	L ₂ in.	Code no.
5/8	21	0.827	13	0.512	15.9	0.626	30	1.181	3	0.118	20.5	0.807	006-1169
3/4	24	0.945	16	0.630	19	0.748	30	1.181	3	0.118	25	0.984	006-1171
1	30	1.181	22	0.866	25.5	1.004	30	1.181	3	0.118	25	0.984	006-1173
1 1/8	34	1.338	26	1.024	28.6	1.126	30	1.181	3	0.118	26	1.024	006-1175

Tongue/groove flange sets, staybolts and nuts version 2.1

Used for **FA 20 code nos. 006-0065/66/67/71/72/73/74 and 036-0061**

Each code no. includes two flanges, two flange gaskets, two staybolts, and four nuts.

Flange dimensions: See table for single flanges.

Separate flange gaskets, ID 32 × OD 44 × 1.5 mm (ID 1.260 × OD 1.732 × 0.059 in.): **Code no. 011L8101** (40 pcs.)

Butt welding DIN (2448)

Tongue/groove flange sets:

Size mm	Size in.	Staybolt	Nut	Code no.
15	1/2	M 12 × 160 mm	M 12	006-1114
20	3/4	M 12 × 160 mm	M 12	006-1115
25	1	M 12 × 160 mm	M 12	006-1116

Soldering DIN (2856)

Tongue/groove flange sets:

Size mm	Staybolt	Nut	Code no.
22	M 12 × 160 mm	M 12	006-1180

Soldering ANSI (B 16.22)

Tongue/groove flange sets:

Size in.	Staybolt	Nut	Code no.
5/8	M 12 × 160 mm	M 12	006-1154
3/8	M 12 × 160 mm	M 12	006-1155
1	M 12 × 160 mm	M 12	006-1156
1 1/8	M 12 × 160 mm	M 12	006-1157

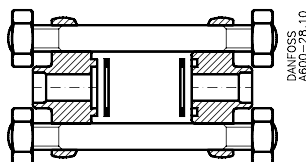

Tongue/tongue flange sets version 2.2

Used for
PHT 85 and PHTQ 85

Each code no. includes two flanges.

Separate flange gaskets,
ID 32 × OD 43.8 × 1.5 mm
(ID 1.260 × OD 1.724 × 0.059 in.);
Code no. 011L8101 (40 pcs.)

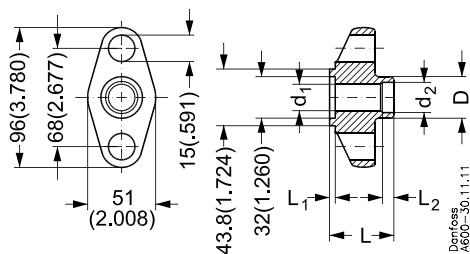

Tongue flange

Butt welding DIN (2448)

Tongue flange set:

Size mm	Size in.	D mm	D in.	d ₁ mm	d ₁ in.	d ₂ mm	d ₂ in.	L mm	L in.	L ₁ mm	L ₁ in.	L ₂ mm	L ₂ in.	Code no.
25	1	34	1.338	26	1.024	28	1.102	37.5	1.476	3	0.118	6	0.236	027N1025

Soldering DIN (2856)

Tongue flange sets:

Size mm	D mm	D in.	d ₁ mm	d ₁ in.	d ₂ mm	d ₂ in.	L mm	L in.	L ₁ mm	L ₁ in.	L ₂ mm	L ₂ in.	Code no.
28	34	1.338	26	1.024	28.1	1.106	33	1.299	3	0.118	22	0.866	027L1028
35	40	1.575	32	1.260	35	1.378	33	1.299	3	0.118	25	0.984	027L1035

Soldering ANSI ((B 16.22))

Tongue flange sets:

Size in.	D mm	D in.	d ₁ mm	d ₁ in.	d ₂ mm	d ₂ in.	L mm	L in.	L ₁ mm	L ₁ in.	L ₂ mm	L ₂ in.	Code no.
1 1/8	34	1.338	26	1.024	28.6	1.126	33	1.299	3	0.118	26	1.024	027L1029
1 3/8	40	1.575	32	1.260	35	1.378	33	1.299	3	0.118	25	0.984	027L1035

Tongue/groove flange sets version 2.3

Used for
FA 20, code nos. 006-0065/66/67/71/72/73/74 and 036-0061, EVSA 25

Flange dimensions:
See drawing for single flanges.

Each code no. includes two flanges.

Separate flange gaskets,
ID 31 × OD 44.2 × 1.5 mm
(ID 1.220 × OD 1.740 × 0.059 in.);
Code no. 011L8101 (40 pcs.)

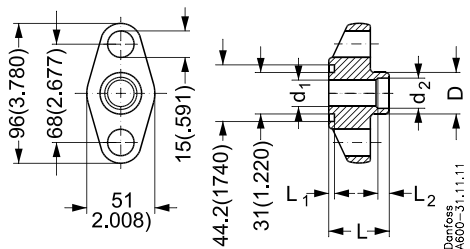

Groove flange

Soldering DIN (2856)

Groove flange set:

Size mm	Size in.	D mm	D in.	d ₁ mm	d ₁ in.	d ₂ mm	d ₂ in.	L mm	L in.	L ₁ mm	L ₁ in.	L ₂ mm	L ₂ in.	Code no.
22	7/8	27	1.063	19	0.748	22	0.866	30	1.181	3	0.118	22	0.866	027L1522

Tongue/tongue flange sets version 3

Used for
FA 20, code nos. 006-0046/48 and 036-0062
TEA 85, TEAQ 85, TEAT 85, TEVA 85,
PM 5, 10, 15, 20, 25, PMC 5, 8, 12, 20,
PMFL 80, PMFH 80,
EVR 20, EVR 25, EVRA 20, EVRA 25

Each code no. includes two flanges.

Separate flange gaskets,
 ID 29 × OD 39 × 1.5 mm
 (ID 1.142 × OD 1.535 × 0.059 in.):
Code no. 027F2175 (20 × 2 pcs.) must be ordered separately.

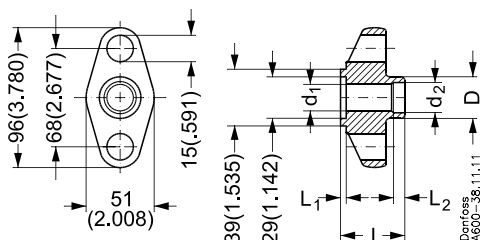

Butt welding DIN (2448)

Tongue flange sets:

Size mm	Size in.	D mm	D in.	d ₁ mm	d ₁ in.	d ₂ mm	d ₂ in.	L mm	L in.	L ₁ mm	L ₁ in.	L ₂ mm	L ₂ in.	Code no.
20	3/4	27	1.063	19	0.748	22	0.866	35	1.378	3	0.118	6	0.236	027N1220
25	1	34	1.339	26	1.024	28	1.102	37.5	1.476	3	0.118	6	0.236	027N1225
32	1 1/4	43	1.693	26	1.024	37	1.457	37.5	1.476	3	0.118	6	0.236	027N1230

Butt welding ANSI (B 36.10)

Tongue flange sets:

Size mm	Size in.	D mm	D in.	d ₁ mm	d ₁ in.	d ₂ mm	d ₂ in.	L mm	L in.	L ₁ mm	L ₁ in.	L ₂ mm	L ₂ in.	Code no.
20	3/4	26.9	1.059	18.9	0.744	18.9	0.744	33	1.299	3	0.118	6	0.236	027N3031
25	1	33.7	1.327	24.5	0.965	24.5	0.965	37.5	1.476	3	0.118	6	0.236	027N3032
32	1 1/4	42.4	1.669	26	1.024	32.6	1.283	37.5	1.476	3	0.118	6	0.236	027N3033

Socket welding ANSI (B 16.11)

Tongue flange sets:

Size mm	Size in.	D mm	D in.	d ₁ mm	d ₁ in.	d ₂ mm	d ₂ in.	L mm	L in.	L ₁ mm	L ₁ in.	L ₂ mm	L ₂ in.	Code no.
20	3/4	37.4	1.472	21	0.827	27.4	1.079	33	1.299	3	0.118	13	0.512	027N2001
25	1	45.6	1.795	26.6	1.047	34.1	1.343	33	1.299	3	0.118	13	0.512	027N2002

FPT inside thread, NPT, ANSI/ASME (B 1.20.1)

Tongue flange sets:

Size mm	Size in.	D mm	D in.	d ₁ mm	d ₁ in.	d ₂ mm	d ₂ in.	L mm	L in.	L ₁ mm	L ₁ in.	L ₂ mm	L ₂ in.	Code no.
20	3/4	37.4	1.472	23	0.906	3/4"-14 NPT	3/4"-14 NPT	33	1.299	3	0.118			027G1001
25	1	45.6	1.795	29	1.142	1"-11.5 NPT	1"-11.5 NPT	33	1.299	3	0.118			027G1002

Soldering DIN (2856)

Tongue flange sets:

Size mm	D mm	D in.	d ₁ mm	d ₁ in.	d ₂ mm	d ₂ in.	L mm	L in.	L ₁ mm	L ₁ in.	L ₂ mm	L ₂ in.	Code no.
22	34	1.338	19	0.748	22	0.866	32	1.260	4	0.157	16.5	0.650	027L1222
28	34	1.338	26	1.024	28	1.102	34	1.338	4	0.157	26	1.024	027L1228

Soldering ANSI (B 16.22)

Tongue flange sets:

Size in.	D mm	D in.	d ₁ mm	d ₁ in.	d ₂ mm	d ₂ in.	L mm	L in.	L ₁ mm	L ₁ in.	L ₂ mm	L ₂ in.	Code no.
7/8	34	1.338	19	0.748	22.2	0.874	32	1.260	4	0.157	16.5	0.650	027L1223
1 1/8	34	1.338	26	1.024	28.6	1.126	34	1.338	4	0.157	26	1.024	027L1229

Tongue/tongue flange sets version 4

Used for
NRVA 25, NRVA 32

Each code no. includes two flanges.

Separate flange gaskets,
ID 43 × OD 57 × 1.5 mm
(ID 1.693 × OD 2.244 × 0.059 in.):
Code no. 027F2176 (40 pcs.)

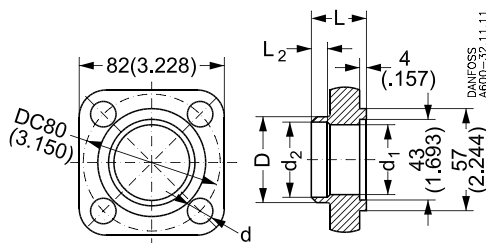

Butt welding DIN (2448)

Tongue flange sets:

Size mm	Size in.	D mm	D in.	d ₁ mm	d ₁ in.	d ₂ mm	d ₂ in.	L mm	L in.	L ₂ mm	L ₂ in.	d mm	d in.	Code no.
25	1	34	1.338	26	1.024	28	1.102	32	1.260	6	0.236	15	0.590	027N1026
32	1¼	43	1.693	35	1.378	37.5	1.476	32	1.260	6	0.236	15	0.590	027N1033

Butt welding ANSI (B 36.10)

Tongue flange sets:

Size mm	Size in.	D mm	D in.	d ₁ mm	d ₁ in.	d ₂ mm	d ₂ in.	L mm	L in.	L ₂ mm	L ₂ in.	d mm	d in.	Code no.
25	1	33.7	1.327	24.5	0.965	24.5	0.965	32	1.260	10	0.394	15	0.591	027N2023
32	1¼	42.4	1.669	32.6	1.2834	32.6	1.283	32	1.260	10	0.394	15	0.591	027N2024

Socket welding ANSI (B 16.11)

Tongue flange sets:

Size mm	Size in.	D mm	D in.	d ₁ mm	d ₁ in.	d ₂ mm	d ₂ in.	L mm	L in.	L ₂ mm	L ₂ in.	d mm	d in.	Code no.
20	¾	37.4	1.472	21	0.827	27.4	1.079	32	1.260	10	0.394	15	0.591	027N2012
25	1	45.7	1.799	26.6	1.047	34.1	1.343	32	1.260	10	0.394	15	0.591	027N2013
32	1¼	55.3	2.177	35	1.378	42.9	1.689	39	1.535	15	0.591	15	0.591	027N2016

FPT inside thread, NPT, ANSI/ASME (B 1.20.1)

Tongue flange sets:

Size mm	Size in.	D mm	D in.	d ₁ mm	d ₁ in.	d ₂ mm	d ₂ in.	L mm	L in.	L ₁ mm	L ₁ in.	Code no.
20	¾	37.4	1.472	23	0.905	¾"-14 NPT	¾"-14 NPT	32	1.260	10	0.394	027G1007
25	1	45.6	1.795	29	1.142	1"-11.5 NPT	1"-11.5 NPT	32	1.260	10	0.394	027G1008

Soldering DIN (2856)

Tongue flange sets:

Size mm	D mm	D in.	d ₁ mm	d ₁ in.	d ₂ mm	d ₂ in.	L mm	L in.	L ₂ mm	L ₂ in.	d mm	d in.	Code no.
35	47	1.850	32	1.260	35	1.378	36.5	1.437	25	0.984	14	0.551	027L2335

Soldering ANSI (B 16.22)

Tongue flange sets:

Size in.	D mm	D in.	d ₁ mm	d ₁ in.	d ₂ mm	d ₂ in.	L mm	L in.	L ₂ mm	L ₂ in.	d mm	d in.	Code no.
1⅜	47	1.850	32	1.260	35	1.378	36.5	1.437	25	0.984	14	0.551	027L2335

Tongue/tongue flange sets version 5

Used for
PHT 125, PHTQ 125, EVSA 35, FA 25, 38E

Each code no. includes two flanges

Separate flange gaskets,
ID 46 × OD 59 × 1.5 mm
(ID 1.811 × OD 2.323 × 0.059 in.):
Code no. 026H0050 (40 pcs.)

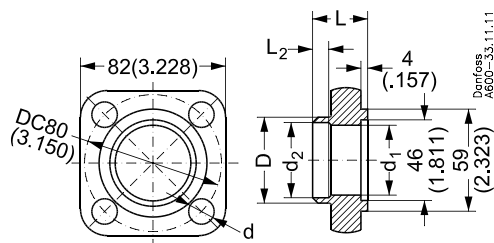

Butt welding DIN (2448)

Tongue flange set:

Size mm	Size in.	D mm	D in.	d ₁ mm	d ₁ in.	d ₂ mm	d ₂ in.	L mm	L in.	L ₂ mm	L ₂ in.	d mm	d in.	Code no.
25	1	34	1.338	26	1.024	28	1.102	32	1.260	6	0.260	15	0.591	006-1117
32	1 1/4	43	1.693	35	1.378	37.5	1.476	32	1.260	6	0.260	15	0.591	027N1032
40	1 1/2	49	1.929	40	1.575	43	1.693	32	1.260	7	0.275	15	0.591	027N1041

Butt welding DIN (2448)

Tongue/groove flange set:

Size in.	D mm	D in.	d ₁ mm	d ₁ in.	d ₂ mm	d ₂ in.	L mm	L in.	L ₂ mm	L ₂ in.	d mm	d in.	Code no.
1 1/8	37	1.457	26	1.024	28.6	1.126	32	1.260	28	1.102	15	0.591	006-1159
1 5/8	52	2.047	38	1.496	41.3	1.626	32	1.260	10	0.394	15	0.591	027L1051

Tongue/tongue flange sets version 6

Used for
NRVA 40 and NRVA 50

Each code no. includes two flanges

Separate flange gaskets,
ID 61 × OD 75 × 1.5 mm:
(ID 2.402 × OD 2.953 × 0.059 in.):
Code no. 027F2178 (40 pcs.)

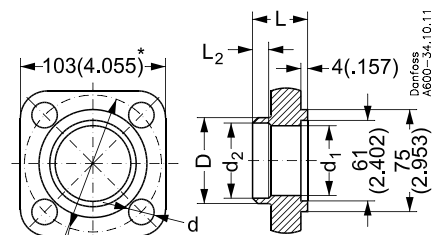

DC = 100(3.937) for weld flanges
DC = 108(4.252) for solder flanges
* = 105(4.134) for solder flanges

Butt welding DIN (2448)

Tongue flange sets:

Size mm	Size in.	D mm	D in.	d ₁ mm	d ₁ in.	d ₂ mm	d ₂ in.	L mm	L in.	L ₂ mm	L ₂ in.	d mm	d in.	Code no.
40	1 1/2	49	1.929	40	1.575	43	1.693	39	1.535	7	0.275	15	0.591	027N1042
50	2	60.5	2.382	52	2.047	54	2.126	39	1.535	8	0.315	15	0.591	027N1051

Butt welding ANSI (B 36.10)

Tongue flange sets:

Size mm	Size in.	D mm	D in.	d ₁ mm	d ₁ in.	d ₂ mm	d ₂ in.	L mm	L in.			d mm	d in.	Code no.
40	1 1/2	48.3	1.902	38.1	1.500	38.1	1.500	39	1.535			15	0.591	027N2025
50	2	60.3	2.374	52.5	2.067	52.5	2.067	39	1.535			15	0.591	027N2026

Continued on next page

Spare parts and accessories
Flanges, Gaskets, Bolts and Nuts
Tongue/tongue flange sets
version 6
(continued)
Socket welding ANSI (B 16.11)

Tongue flange sets:

Size mm	Size in.	D mm	D in.	d ₁ mm	d ₁ in.	d ₂ mm	d ₂ in.	L mm	L in.	L ₂ mm	L ₂ in.	d mm	d in.	Code no.
32	1¼	55.3	2.177	35	1.378	42.9	1.689	39	1.535	13	0.512	15	0.591	027N2014
40	1½	61.9	2.437	40.8	1.606	49	1.929	39	1.535	13	0.512	15	0.591	027N2015

Soldering DIN (2856)

Tongue flange sets:

Size mm	D mm	D in.	d ₁ mm	d ₁ in.	d ₂ mm	d ₂ in.	L mm	L in.	L ₂ mm	L ₂ in.	d mm	d in.	Code no.
54	64	2.520	50	1.969	54	2.130	45.5	1.791	33	1.299	16	0.630	027L2554

Soldering ANSI (B 16.22)

Tongue flange sets:

Size in.	D mm	D in.	d ₁ mm	d ₁ in.	d ₂ mm	d ₂ in.	L mm	L in.	L ₂ mm	L ₂ in.	d mm	d in.	Code no.
2⅞	64	2.520	50	1.969	54	2.130	45.5	1.791	33	1.299	16	0.630	027L2554

Tongue/tongue flange sets version 7

 Used for **PHT 200, PHTQ 200, PHT 300, PHTQ 300, EVSA 50**

Each code no. includes two flanges.

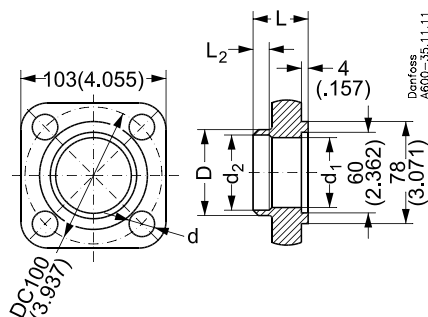
 Separate flange gaskets,
 ID 61 × OD 75 × 1.5 mm
 (ID 2.402 × OD 2.953 × 0.059 in.):
Code no. 026H0051 (40 pcs.)

Butt welding DIN (2448)

Tongue flange sets:

Size mm	Size in.	D mm	D in.	d ₁ mm	d ₁ in.	d ₂ mm	d ₂ in.	L mm	L in.	L ₂ mm	L ₂ in.	d mm	d in.	Code no.
40	1½	49	1.929	40	1.575	43	1.693	39	1.535	7	0.275	15	0.590	027N1040
50	2	60.5	2.382	52	2.047	54	2.126	39	1.535	8	0.315	15	0.590	027N1050

Soldering ANSI (B 16.22)

Tongue flange sets:

Size mm	Size in.	D mm	D in.	d ₁ mm	d ₁ in.	d ₂ mm	d ₂ in.	L mm	L in.	L ₂ mm	L ₂ in.	d mm	d in.	Code no.
	2⅞	65	2.559	50	1.968	54	2.126	39	1.535	32	1.260	15	0.590	027L1050

Tongue/tongue flange sets version 8

Used for **NRVA 65**

Each code no. includes two flanges.

Separate flange gaskets,
ID 95 × OD 109 × 2 mm
(ID 3.741 × OD 4.291 × 0.079 in.):
Code no. 020-2136 (40 pcs.)

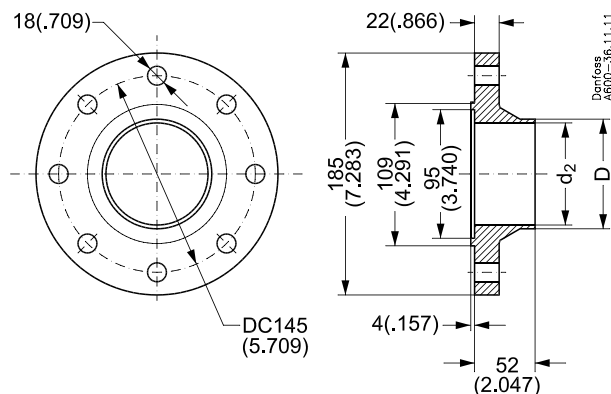

Butt welding DIN (2448)

Tongue flange sets:

Size mm	Size in.	D mm	D in.	d ₂ mm	d ₂ in.													Code no.
65	2½	76	2.992	70.3	2.768													027N1055

Butt welding ANSI (B 36.10)

Tongue flange sets:

Size mm	Size in.	D mm	D in.	d ₂ mm	d ₂ in.													Code no.
65	2½	73	2.874	62.5	2.461													027N2027

Sealing recess flanges version 9A

Used for **WVS 50 and WVTS 50**

Each code no. includes two flanges.

Separate flange gaskets,
ID 57 × OD 107 × 2 mm
(ID 2.244 × OD 4.212 × 0.079 in.):
Code no. 016D0071 (40 pcs.)

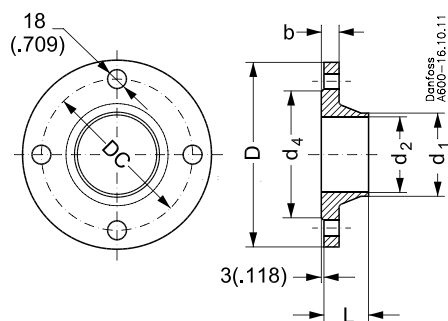

Butt welding DIN (2448)

Sealing recess flange:

Size mm	Size in.	D mm	D in.	d ₁ mm	d ₁ in.	d ₂ mm	d ₂ in.	d ₄ mm	d ₄ in.	L mm	L in.	b mm	b in.	DC mm	DC in.			Code no.
50	2	165	6.496	60.3	3.374	50.0	1.968	102	4.016	45	1.772	18	0.709	125	4.921			027N3050

Pipe thread ISO 228/1 (BSP int.)

Sealing recess flange:

Size mm	Size in.	D mm	D in.	d ₁ mm	d ₁ in.	d ₂ mm	d ₂ in.	d ₄ mm	d ₄ in.	L mm	L in.	b mm	b in.	DC mm	DC in.			Code no.
50	G 2	165	6.496					102	4.016	28	1.102	18	0.709	125	4.921			027N3050

Sealing recess flanges version 9B

Used for
WVS 65, WVTS 65, EVSI 65

Each code no. includes two flanges.

Separate flange gaskets,
ID 76 × OD 127 × 2 mm
(ID 2.992 × OD 5 × 0.079 in.):
Code no. 016D0072 (40 pcs.)

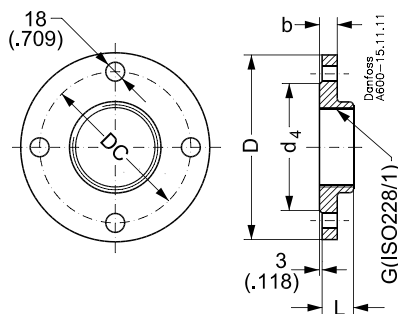

Butt welding DIN (2448)

Sealing recess flange:

Size mm	Size in.	D mm	D in.	d ₁ mm	d ₁ in.	d ₂ mm	d ₂ in.	d ₄ mm	d ₄ in.	L mm	L in.	b mm	b in.	DC mm	DC in.	Code no.
65	2 1/2	185	7.283	76.1	2.996	65.0	2.559	122	4.803	45	1.772	18	0.709	145	5.709	027N3065

Pipe thread ISO 228/1 (BSP int.)

Sealing recess flange:

Size mm	Size in.	D mm	D in.	d ₁ mm	d ₁ in.	d ₂ mm	d ₂ in.	d ₄ mm	d ₄ in.	L mm	L in.	b mm	b in.	DC mm	DC in.	Code no.
G 65	G 2 1/2	185	7.283					122	4.803	32	1.260	18	0.709	145	5.709	027G3065

Sealing recess flanges version 9C

Used for
WVS 80, WVTS 80, EVSI 80

Each code no. includes two flanges.

Separate flange gaskets,
ID 89 × OD 142 × 2 mm
(ID 3.504 × OD 5.590 × 0.079 in.):
Code no. 016D0073 (40 pcs.)

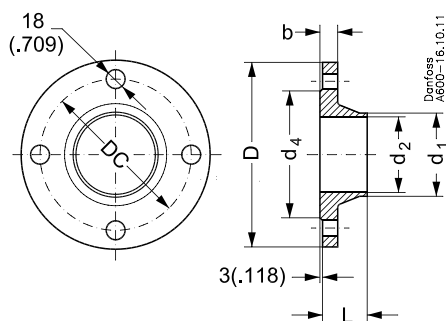

Butt welding DIN (2448)

Sealing recess flange:

Size mm	Size in.	D mm	D in.	d ₁ mm	d ₁ in.	d ₂ mm	d ₂ in.	d ₄ mm	d ₄ in.	L mm	L in.	b mm	b in.	DC mm	DC in.	Code no.
75	3	200	7.874	88.9	3.500	80.0	3.150	138	5.433	50	1.968	20	1.787	160	6.299	027N3080

Pipe thread ISO 228/1 (BSP int.)

Sealing recess flange:

Size mm	Size in.	D mm	D in.	d ₁ mm	d ₁ in.	d ₂ mm	d ₂ in.	d ₄ mm	d ₄ in.	L mm	L in.	b mm	b in.	DC mm	DC in.	Code no.
75	G 3	200	7.874					138	5.433	34	1.338	20	1.787	160	6.299	027G3080

Sealing recess flanges version 9D

Used for
WVS 100, WVTS 100, EVSI 100

Each code no. includes two flanges.

Separate flange gaskets,
ID 108 × OD 162 × 2 mm
(ID 4.252 × OD 6.378 × 0.079 in.):
Code no. 016D0074 (40 pcs.)

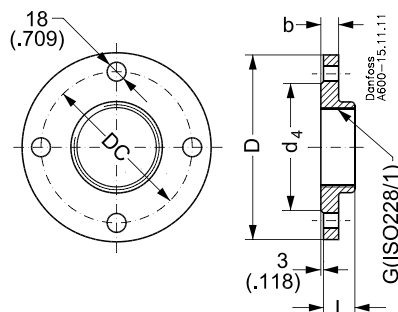

Butt welding DIN (2448)

Sealing recess flange:

Size mm	Size in.	D mm	D in.	d ₁ mm	d ₁ in.	d ₂ mm	d ₂ in.	d ₄ mm	d ₄ in.	L mm	L in.	b mm	b in.	DC mm	DC in.	Code no.
100	4	220	8.661	114.3	4.500	107.1	4.216	158	6.220	52	2.047	20	1.787	180	7.087	027N3100

Pipe thread ISO 228/1 (BSP int.)

Sealing recess flange:

Size mm	Size in.	D mm	D in.	d ₁ mm	d ₁ in.	d ₂ mm	d ₂ in.	d ₄ mm	d ₄ in.	L mm	L in.	b mm	b in.	DC mm	DC in.	Code no.
100	G 4	220	8.661					158	6.220	38	1.496	20	1.787	180	7.087	027G3100

Tongue/tongue flange sets version 10

Used for
PM 32, PML 32, PMLX 32, PMFL 125, PMFH 125

Each code no. includes two flanges.

Separate flange gaskets,
ID 43 × OD 57 × 1.5 mm
(ID 1.693 × OD 2.244 × 0.059 in.):
Code no. 027F2176 (40 pcs.)

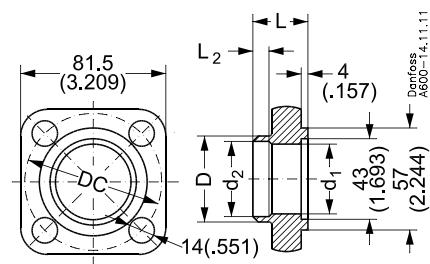

Butt welding DIN (2448)

Tongue flange sets:

Size mm	Size in.	D mm	D in.	d ₁ mm	d ₁ in.	d ₂ mm	d ₂ in.	L mm	L in.	L ₂ mm	L ₂ in.	DC mm	DC in.	Code no.
32	1 1/4	43	1.693	37	1.457	37	1.457	36.5	1.437	15	0.590	80	3.150	027N2332
40	1 1/2	49	1.929	38	1.496	43	1.693	36.5	1.437	15	0.590	80	3.150	027N2340

Butt welding ANSI (B 16.22)

Tongue flange sets:

Size mm	Size in.	D mm	D in.	d ₁ mm	d ₁ in.	d ₂ mm	d ₂ in.	L mm	L in.			DC mm	DC in.	Code no.
32	1 1/4	42.4	1.669	32.6	1.283	32.6	1.283	36.5	1.437			80	3.150	027N3034
40	1 1/2	48.3	1.902	38.1	1.500	38.1	1.500	36.5	1.437			80	3.150	027N3035

Continued on next page

**Tongue/tongue flange sets
version 10**
(continued)

Socket welding ANSI (B 16.11)

Tongue flanges:

Size mm	Size in.	D mm	D in.	d ₁ mm	d ₁ in.	d ₂ mm	d ₂ in.	L mm	L in.	L ₂ mm	L ₂ in.	DC mm	DC in.	Code no.
32	1 ¹ / ₄	52	2.047	35	1.378	42.9	1.689	36.5	1.437	13	1.512	80	3.150	027N2003

Soldering DIN (2856)

Tongue flanges:

Size mm	D mm	D in.	d ₁ mm	d ₁ in.	d ₂ mm	d ₂ in.	L mm	L in.	L ₂ mm	L ₂ in.	DC mm	DC in.	Code no.
35	47	1.850	32	1.260	45	1.378	36.5	1.437	25	0.984	14	0.551	027L2335

Soldering ANSI (B 16.22)

Tongue flange sets:

Size in.	D mm	D in.	d ₁ mm	d ₁ in.	d ₂ mm	d ₂ in.	L mm	L in.	L ₂ mm	L ₂ in.	DC mm	DC in.	Code no.
1 ³ / ₈	47	1.850	32	1.260	45	1.378	36.5	1.437	25	0.984	14	0.551	027L2335

**Tongue/tongue flange sets
version 11**

 Used for
**PM 40, PML 40, PMLX 40, PMFL 200,
PMFH 200**

Each code no. includes two flanges.

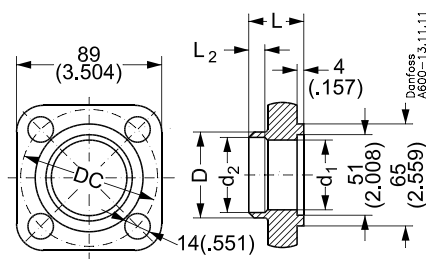
 Separate flange gaskets,
ID 51 × OD 65 × 1.5 mm
(ID 2.008 × OD 2.559 × 0.059 in.):
Code no. 027F2177 (40 pcs.)

Butt welding DIN (2448)

Tongue flange sets:

Size mm	Size in.	D mm	D in.	d ₁ mm	d ₁ in.	d ₂ mm	d ₂ in.	L mm	L in.	L ₂ mm	L ₂ in.	DC mm	DC in.	Code no.
40	1 ¹ / ₂	49	1.929	43	1.693	43	1.693	43.5	1.712	15	0.590	90	3.543	027N2440
50	2	60.5	2.382	49	1.929	54	2.126	43.5	1.712	15	0.590	90	3.543	027N2450

Butt welding ANSI (B 36.10)

Tongue flange sets:

Size mm	Size in.	D mm	D in.	d ₁ mm	d ₁ in.	d ₂ mm	d ₂ in.	L mm	L in.	DC mm	DC in.	Code no.
40	1 ¹ / ₂	48.2	1.898	38.1	1.500	38.1	1.500	43.5	1.713	90	3.543	027N3036
50	2	60.3	2.374	49	1.929	49	1.929	43.5	1.713	90	3.543	027N3037

Butt welding ANSI (B 16.11)

Tongue flange sets:

Size mm	Size in.	D mm	D in.	d ₁ mm	d ₁ in.	d ₂ mm	d ₂ in.	L mm	L in.	L ₂ mm	L ₂ in.	DC mm	DC in.	Code no.
40	1 ¹ / ₂	61.9	2.437	40.8	1.606	48.9	1.925	43.5	1.713	13	0.512	90	3.543	027N2004

Continued on next page

**Tongue/tongue flange sets
version 11**
(continued)

Soldering din (2856)
Tongue flange set:

Size mm	D mm	D in.	d ₁ mm	d ₁ in.	d ₂ mm	d ₂ in.	L mm	L in.	L ₂ mm	L ₂ in.	DC mm	DC in.	Code no.
42	54	2.126	38	1.496	41	1.614	43.5	1.712	28	1.102	90	3.543	027L2442

Soldering ANSI (B 16.22)
Tongue flange sets:

Size in.	D mm	D in.	d ₁ mm	d ₁ in.	d ₂ mm	d ₂ in.	L mm	L in.	L ₂ mm	L ₂ in.	DC mm	DC in.	Code no.
1 ⁵ / ₈	54	2.126	38	1.496	41	1.614	43.5	1.712	28	1.102	90	3.543	027L2441

**Tongue/tongue flange sets
version 12**

Used for
**PM 50, PML 50, PMLX 50, PMFL 300,
PMFH 300**

Each code no. includes two flanges.

Separate flange gaskets,
ID 61 × OD 75 × 1.5 mm
(ID 2.402 × OD 2.953 × 0.059 in.):
Code no. 027F2178 (40 pcs.)

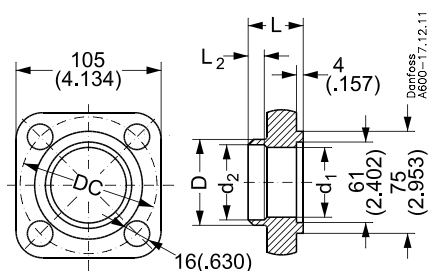

Butt welding DIN (2448)
Tongue flange sets:

Size mm	Size in.	D mm	D in.	d ₁ mm	d ₁ in.	d ₂ mm	d ₂ in.	L mm	L in.	L ₂ mm	L ₂ in.	DC mm	DC in.	Code no.
50	2	60.5	2.382	54	2.126	54	2.126	45.5	1.791	21	0.827	108	4.252	027N2550
65	2 ¹ / ₂	76.5	3.012	59	2.323	70	2.756	45.5	1.791	21	0.827	108	4.252	027N2565

Butt welding ANSI (B 36.10)
Tongue flange sets:

Size mm	Size in.	D mm	D in.	d ₁ mm	d ₁ in.	d ₂ mm	d ₂ in.	L mm	L in.	L ₂ mm	L ₂ in.	DC mm	DC in.	Code no.
50	2	60.3	2.374	52.5	2.067	52.5	2.067	45.5	1.791			108	4.252	027N3038
65	2 ¹ / ₂	73	2.874	59	2.323	62.5	2.461	45.5	1.791	6	0.236	108	4.252	027N3039

Socket welding ANSI (B 16.11)
Tongue flange sets:

Size mm	Size in.	D mm	D in.	d ₁ mm	d ₁ in.	d ₂ mm	d ₂ in.	L mm	L in.	L ₂ mm	L ₂ in.	DC mm	DC in.	Code no.
50	2	75.5	2.972	61	2.402	61.4	2.417	45.5	1.791	17	0.669	108	4.252	027N2005

Soldering DIN (2856)
Tongue flange set:

Size mm	D mm	D in.	d ₁ mm	d ₁ in.	d ₂ mm	d ₂ in.	L mm	L in.	L ₂ mm	L ₂ in.	DC mm	DC in.	Code no.
54	65	2.559	50	1.969	54.1	2.130	45.5	1.791	33	1.299	108	4.252	027L2554

Soldering ANSI (B 16.22)
Tongue flange sets:

Size in.	D mm	D in.	d ₁ mm	d ₁ in.	d ₂ mm	d ₂ in.	L mm	L in.	L ₂ mm	L ₂ in.	DC mm	DC in.	Code no.
2 ¹ / ₈	65	2.559	50	1.969	54.1	2.130	45.5	1.791	33	1.299	108	4.252	027L2554

Tongue/tongue flange sets version 13

Used for
PM 65, PML 65, PMLX 65, PMFH 500

Each code no. includes two flanges.

Separate flange gaskets,
ID 73 × OD 87 × 1.5 mm
(ID 2.874 × OD 3.425 × 0.059 in.):
Code no. 027F2179 (40 pcs.)

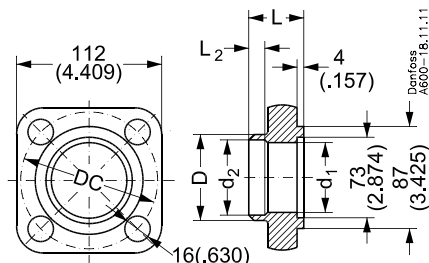

Butt welding DIN (2448)

Tongue flange sets:

Size mm	Size in.	D mm	D in.	d ₁ mm	d ₁ in.	d ₂ mm	d ₂ in.	L mm	L in.	L ₂ mm	L ₂ in.	DC mm	DC in.	Code no.
65	2 1/2	76.5	3.012	70	2.756	70	2.756	47.5	1.870	21	0.827	118	4.646	027N2665
80	3	89	3.504	71	2.795	82	3.228	47.5	1.870	21	0.827	118	4.646	027N2680

Butt welding ANSI (B 36.10)

Tongue flange sets:

Size mm	Size in.	D mm	D in.	d ₁ mm	d ₁ in.	d ₂ mm	d ₂ in.	L mm	L in.	L ₂ mm	L ₂ in.	DC mm	DC in.	Code no.
65	2 1/2	73	2.874	62.6	2.465	62.6	2.465	47.5	1.870			118	4.646	027N3040
80	3	88.9	3.500	71	2.795	77.9	3.067	47.5	1.870	10	0.394	118	4.646	027N3041

Socket welding ANSI (B 16.11)

Tongue flange sets:

Size mm	Size in.	D mm	D in.	d ₁ mm	d ₁ in.	d ₂ mm	d ₂ in.	L mm	L in.	L ₂ mm	L ₂ in.	DC mm	DC in.	Code no.
65	2 1/2	91.9	3.618	64	2.520	74.2	2.921	47.5	1.870	17	0.669	118	4.646	027N2006

Soldering DIN (2856)

Tongue flange sets:

Size mm	Size in.	D mm	D in.	d ₁ mm	d ₁ in.	d ₂ mm	d ₂ in.	L mm	L in.	L ₂ mm	L ₂ in.	DC mm	DC in.	Code no.
76		81	3.189	63	2.480	66.8	2.630	45.5	1.791	33	1.299	118	4.646	027L2666

Soldering ANSI (B 16.22)

Tongue flange sets:

Size mm	Size in.	D mm	D in.	d ₁ mm	d ₁ in.	d ₂ mm	d ₂ in.	L mm	L in.	L ₂ mm	L ₂ in.	DC mm	DC in.	Code no.
	2 5/8	88	3.464	70	2.756	76	2.992	47.5	1.870	33	1.299	118	4.646	027L2676

Staybolt sets

Materials:
C 22 B2, W. no. 1.5508

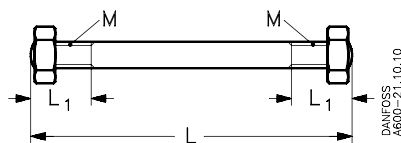

Staybolts, nuts and flange gaskets for	Thread	L ₁ mm	L ₁ in.	L mm	L in.	Code no.
TE 12 without filter, FA 15	M 12	19	0.748	127	5.000	006-1108
TE 12 with filter	M 12	19	0.748	180	7.087	006-1102
TEA 20, TEAT 20 and TEVA 20 without filter	M 12	19	0.748	115	4.527	006-1107
TEA 20, TEAT 20 and TEVA 20 with filter	M 12	19	0.748	170	6.693	006-1103
TEA 85, TEAT 85 and TEVA 85 without filter	M 12	25	0.984	132	5.197	006-1109
TEA 85, TEAT 85 and TEVA 85 with filter	M 12	25	0.984	206	8.110	006-1106
EVR 15, EVRA 3, EVRA 10 and 15 without filter	M 12	19	0.748	135	5.315	006-1134
EVR 20 and 25, EVRA 20 and 25 without filter	M 12	22	0.866	167	6.575	006-1137
EVRA 10 and 15 (GG 25) with filter	M 12	19	0.748	188	7.401	006-1104
EVRA 10 (GGG 40.3) + FA 15	M 12	19	0.748	107	4.212	006-1101
EVRA 20 and 25 (GG 25) with filter	M 12	22	0.866	240	9.449	006-1105
EVRA 20 (GGG 40.3) + FA 20	M 12	19	0.748	127	5.000	006-1108
FA 20	M 12	22	0.866	160	6.299	006-1136
NRVA 15 and 20	M 12	19	0.748	115	4.527	006-1107
NRVA 25 and 32	M 12	12	0.472	148	5.827	006-1135
NRVA 40 and 50	M 12	22	0.866	167	6.575	006-1137
NRVA 65	M 16	25	0.984	200	7.874	006-1138

Description	Qty	Description	Qty
Code no. 006-1101:		Code no. 006-1108:	
Staybolt M 12 x 107 mm (4.213 in.)	2	Staybolt M 12 x 127 mm (5 in.)	2
Nut M 12	4	Nut M 12	4
Flange gasket	3	Flange gasket	3
Code no. 006-1102:		Code no. 006-1109:	
Staybolt M 12 x 180 mm (7.087 in.)	2	Staybolt M 12 x 132 mm (7.197 in.)	2
Nut M 12	4	Nut M 12	4
Flange gasket	3	Flange gasket	3
Code no. 006-1103:		Code no. 006-1134:	
Staybolt M 12 x 170 mm (6.693 in.)	2	Staybolt M 12 x 135 mm (5.315 in.)	2
Nut M 12	4	Nut M 12	4
Flange gasket	3	Flange gasket	3
Code no. 006-1104:		Code no. 006-1135:	
Staybolt M 12 x 188 mm (7.402 in.)	2	Staybolt M 12 x 148 mm (5.827 in.)	4
Nut M 12	4	Nut M 12	8
Flange gasket	3	Flange gasket	2
Code no. 006-1105:		Code no. 006-1136:	
Staybolt M 12 x 240 mm (9.449 in.)	2	Staybolt M 12 x 206 mm (6.299 in.)	2
Nut M 12	4	Nut M 12	4
Flange gasket	3	Flange gasket	2
Code no. 006-1106:		Code no. 006-1137:	
Staybolt M 12 x 206 mm (8.110 in.)	2	Staybolt M 12 x 167 mm (6.575 in.)	4
Nut M 12	4	Nut M 12	8
Flange gasket	3	Flange gasket	2
Code no. 006-1107:		Code no. 006-1138:	
Staybolt M 12 x 115 mm (4.527 in.)	2	Staybolt M 12 x 200 mm (7.874 in.)	8
Nut M 12	4	Nut M 12	16
Flange gasket	3	Flange gasket	2

**Bolts and nuts
for flange connection**

Materials:
Bolts, property class 8.8 to ISO 898
Nuts, property class 8 to ISO 898

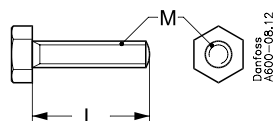

Type	M mm	L mm	L in.	Qty	Code no. for bolts	Code no. for nuts
FA 25	M 12	35	1.378	8	006-1139 ¹⁾	
EVRA/T 10,15	M 12	35	1.378	4	006-1139	
PHT/Q 125, EVSA 35 and 50, 38E	M 12	40	1.575	8	006-1140 ¹⁾	
PM 5 to 25, PMC 5 to 20	M 12	45	1.772	4	006-1141	
PM 32 to 40	M 12	45	1.772	8	006-1141 ¹⁾	
PML/PMLX 32 to 40	M 12	45	1.772	8	006-1141 ¹⁾	
PMFL 80/PMFH 80	M 12	45	1.772	4	006-1141	
PMFL 125 to 200	M 12	45	1.772	8	006-1141 ¹⁾	
PMFH 125 to 200	M 12	45	1.772	8	006-1141 ¹⁾	
PHT/Q 85, EVSA 25	M 12	45	1.772	4	006-1141	
PHT/Q 300	M 12	45	1.772	8	006-1141 ¹⁾	
EVRA/T 20, EVRA 25	M 12	45	1.772	4	006-1141	
PM 50, PML 50, PMLX 50	M 14	65	2.559	8	006-1142 ¹⁾	006-1146 ¹⁾
PMFL 300/PMFH 300	M 14	65	2.559	8	006-1142 ¹⁾	006-1146 ¹⁾
PM 65, PML 65, PMLX 65	M 14	70	2.756	8	006-1143 ¹⁾	006-1146 ¹⁾
PMFH 500	M 14	70	2.756	8	006-1143 ¹⁾	006-1146 ¹⁾
WVS/WVTS 50, 65, 80	M 16	60	2.362	8	006-1144 ¹⁾	006-1147 ¹⁾
EVSI 65, 80	M 16	60	2.362	8	006-1144 ¹⁾	006-1147 ¹⁾
WVS/WVTS 100	M 16	60	2.362	8	006-1144 ¹⁾	006-1147 ¹⁾
EVSI 100	M 16	60	2.362	8	006-1144 ¹⁾	006-1147 ¹⁾
PM 80, PML 80, PMLX 80	M 20	70	2.756	16	027F2126 ²⁾	
PM 100, PML 100, PMLX 100	M 20	75	2.953	16	027F2127 ²⁾	
PM 125, PML 125, PMLX 125	M 24	80	3.150	16	027F2128 ²⁾	

1) For qty 8 pcs., please order 2 × code nos.

2) Bolts and nuts included.

Stainless steel flanges

Materials:
Stainless steel,
W no. 1.4541 to DIN 17440

Test certificate to EN 10204/DIN 50049-3.1 B
can be delivered on request

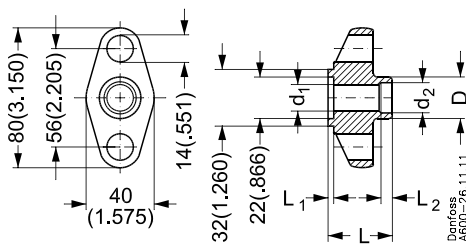

Butt welding DIN (2448)

Tongue flange set:

Size mm	Size in.	D mm	D in.	d ₁ mm	d ₁ in.	d ₂ mm	d ₂ in.	L mm	L in.	L ₁ mm	L ₁ in.	L ₂ mm	L ₂ in.	Code no.
15	1/2	22	0.866	14	0.551	17	0.669	32.5	1.280	3	0.118	6	0.236	192H3253
20	3/4	27	1.063	19	0.748	22	0.866	32.5	1.280	3	0.118	6	0.236	192H3254

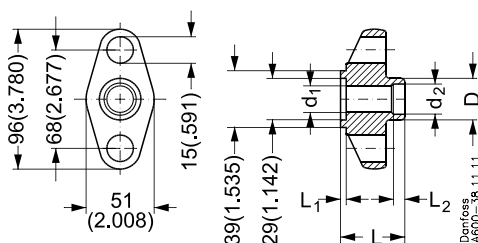

Tongue/tongue flange sets version 3

Used for
FA 20, code nos. 006-0046/48 and 036-0062
TEA 85, TEAQ 85, TEAT 85, TEVA 85,
PM 5, 10, 15, 20, 25, PMC 5, 8, 12, 20,
PMFL 80, PMFH 80,
EVR 20, EVR 25, EVRA 20, EVRA 25

Each code no. includes two flanges.

Flange gaskets,
ID 29 × OD 39 × 1.5 mm
(ID 1.142 × OD 1.535 × 0.059 in.):
Code no. 027F2175 (40 pcs.)

Butt welding DIN (2448)

Tongue flange set:

Size mm	Size in.	D mm	D in.	d ₁ mm	d ₁ in.	d ₂ mm	d ₂ in.	L mm	L in.	L ₁ mm	L ₁ in.	L ₂ mm	L ₂ in.	Code no.
20	3/4	27	1.063	19	0.748	22	0.866	35	1.378	3	0.118	6	0.236	192H3045
25	1	34	1.339	26	1.024	28	1.102	37.5	1.476	3	0.118	6	0.236	192H3014

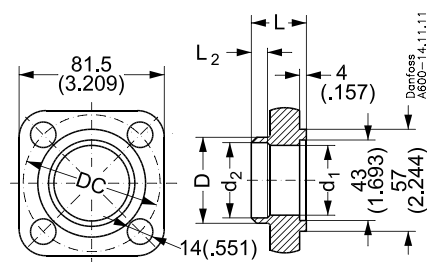

Tongue/tongue flange sets version 10

Used for
PM 32, PML 32, PMLX 32, PMFL 125,
PMFH 125

Each code no. includes two flanges.

Separate flange gaskets,
ID 43 × OD 57 × 1.5 mm:
(ID 1.693 × OD 2.244 × 0.059 in.):
Code no. 027F2176 (40 pcs.)

Butt welding DIN (2448)

Tongue flange set:

Size mm	Size in.	D mm	D in.	d ₁ mm	d ₁ in.	d ₂ mm	d ₂ in.	L mm	L in.	L ₂ mm	L ₂ in.	DC mm	DC in.	Code no.
40	1 1/2	49	1.929	38	1.496	43	1.693	36.5	1.437	15	0.590	80	3.150	192H3016

Tongue/tongue flange sets version 11

Used for
**PM 40, PML 40, PMLX 40, PMFL 200,
PMFH 200**

Each code no. includes two flanges.

Separate flange gaskets,
ID 51 × OD 65 × 1.5 mm
(ID 2.008 × OD 2.560 × 0.059 in.);
Code no. 027F2177 (40 pcs.)

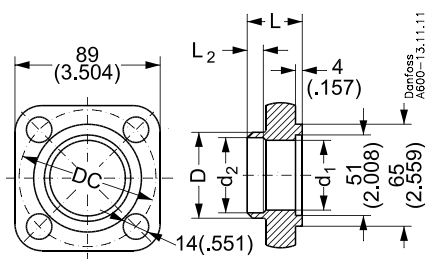

Butt welding DIN (2448)

Tongue flange set:

Size mm	Size in.	D mm	D in.	d ₁ mm	d ₁ in.	d ₂ mm	d ₂ in.	L mm	L in.	L ₂ mm	L ₂ in.	DC mm	DC in.	Code no.
50	2	60.5	2.382	49	1.929	54	2.126	43.5	1.712	15	0.590	90	3.543	192H3018

Tongue/tongue flange sets version 12

Used for
**PM 50, PML 50, PMLX 50, PMFL 300,
PMFH 300**

Each code no. includes two flanges.

Separate flange gaskets,
ID 61 × OD 75 × 1.5 mm
(ID 2.406 × OD 2.953 × 0.059 in.);
Code no. 027F2178 (40 pcs.)

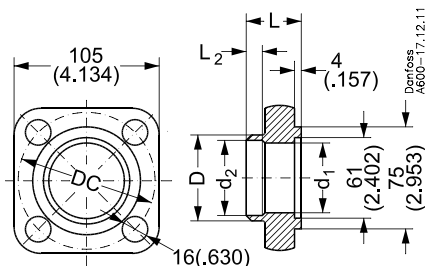

Butt welding DIN (2448)

Tongue flange set:

Size mm	Size in.	D mm	D in.	d ₁ mm	d ₁ in.	d ₂ mm	d ₂ in.	L mm	L in.	L ₂ mm	L ₂ in.	DC mm	DC in.	Code no.
65	2½	76.5	3.012	59	2.323	70	2.756	45.5	1.791	21	0.827	108	4.252	192H3020

Tongue/tongue flange sets version 13

Used for
PM 65, PML 65, PMLX 65, PMFH 500

Each code no. includes two flanges.

Separate flange gaskets,
ID 73 × OD 87 × 1.5 mm
(ID 2.874 × OD 3.425 × 0.059 in.);
Code no. 027F2179 (40 pcs.)

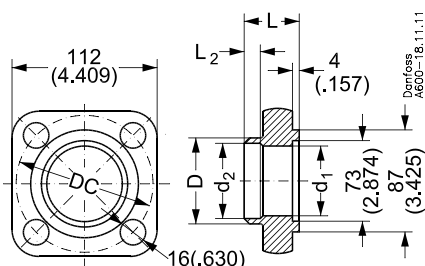

Butt welding DIN (2448)

Tongue flange set:

Size mm	Size in.	D mm	D in.	d ₁ mm	d ₁ in.	d ₂ mm	d ₂ in.	L mm	L in.	L ₂ mm	L ₂ in.	DC mm	DC in.	Code no.
80	3	89	3.504	71	2.795	82	3.228	47.5	1.870	21	0.827	118	4.646	192H3022

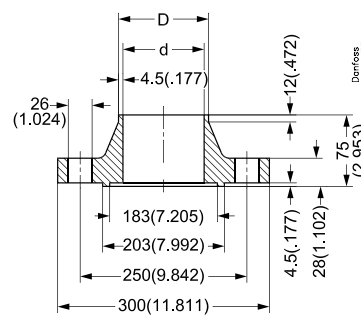
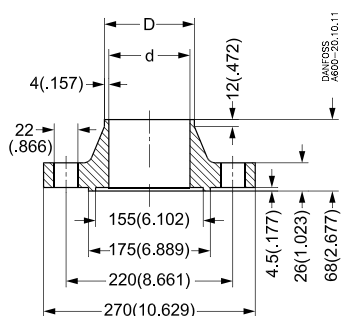
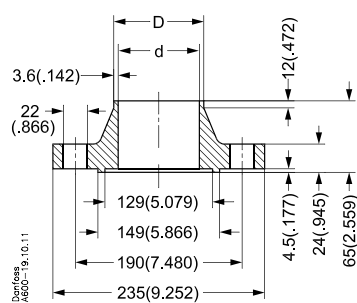

Fig. 1

Fig. 2

Fig. 3

Butt welding DIN (2448)

Tongue flange set:

Size mm	Size in.	D mm	D in.	d mm	d in.	Type	Used for	Code no.
100 (Fig. 1)	4	114.3	4.500	107.1	4.217	14A	PM 80, PML 80, PMLX 80	192H3012
125 (Fig. 2)	5	139.7	5.500	131.7	5.185	14B	PM 100, PML 100, PMLX 100	192H3013
150 (Fig. 3)	6	168.3	6.626	159.3	6.272	14C	PM 125, PML 125, PMLX 125	192H3014

Stainless steel bolts and nuts for flange connections

Materials:
Property class A2 or A4 to DIN 267

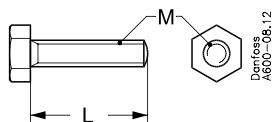

Type	M	L mm	L in.	Qty	Code no.
PM 5 to 25, PMC 5 to 20	M 12	45	1.772	4	027F2220
PM 32 to 40	M 12	45	1.772	8	027F2221
PML/PMLX 32 to 40	M 12	45	1.772	8	027F2221
PMFL 80, PMFH 80	M 12	45	1.772	4	027F2220
PMFL 125, PMFL 200	M 12	45	1.772	8	027F2221
PMFH 125, PMFH 200	M 12	45	1.772	8	027F2221
PHT/Q 85, EVSA 25	M 12	45	1.772	4	027F2220
PHT/Q 125 to 300	M 12	45	1.772	8	027F2221
EVRA/T 20, EVRA 25	M 12	45	1.772	4	027F2220
PM 50, PML 50, PMLX 50, PMFL/H 300	M 14	65	2.559	8	027F2222 ¹⁾
PM 65, PML 65, PMLX 65, PMFH 500	M 14	70	2.756	8	027F2223 ¹⁾
PM 80, PML 80, PMLX 80	M 20	70	2.756	16	027F2224 ¹⁾
PM 100, PML 100, PMLX 100	M 20	75	2.953	16	027F2225 ¹⁾
PM 125, PML 125, PMLX 125	M 24	80	3.150	16	027F2226 ¹⁾

1) Bolts and nuts included.

Bolts for top and bottom cover

Main valves, type PM

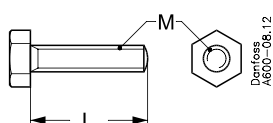

Type	M	L mm	L in.	Qty	Code no.
PM 5 to 32, PMC 5 to 20	M 10	30	1.181	8	027F2260
PML32, PMLX 32	M 10	30	1.181	8	027F2260
PMFL/PMFH 80 to 125	M 10	30	1.181	8	027F2260
PM 40, PM 50	M 12	35	1.378	8	027F2262
PML 40, PMLX 40	M 12	35	1.378	8	027F2262
PML 50, PMLX 50	M 12	35	1.378	8	027F2262
PMFL/PMFH 200 to 300	M 12	35	1.378	8	027F2262
PM 65, PML 65, PMLX 65	M 14	40	1.575	8	027F2264
PMFH 500	M 14	40	1.575	8	027F2264
PM 80, PML 80, PMLX 80	M 14	50	1.968	12	027F2265 ¹⁾
PM 100, PML 100, PMLX 100	M 14	50	1.968	16	027F2266 ¹⁾
PM 125, PML 125, PMLX 125	M 16	60	2.362	16	027F2267 ¹⁾

1) Bolts and nuts included.