

027R9525

027R9525

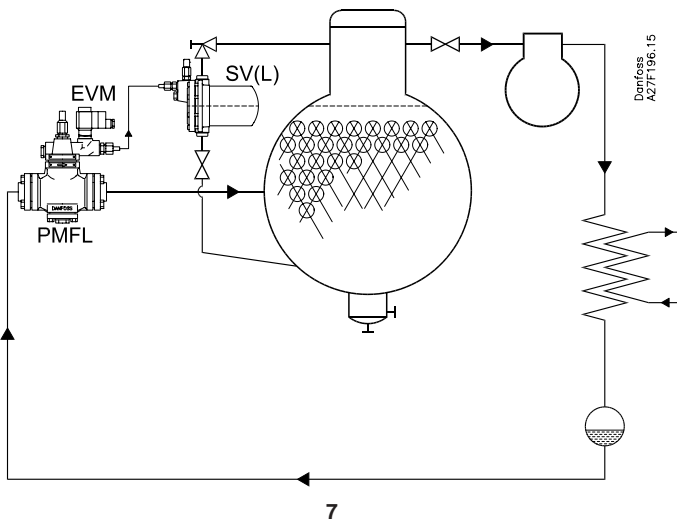

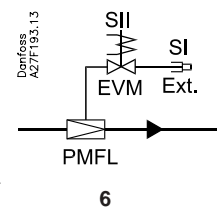
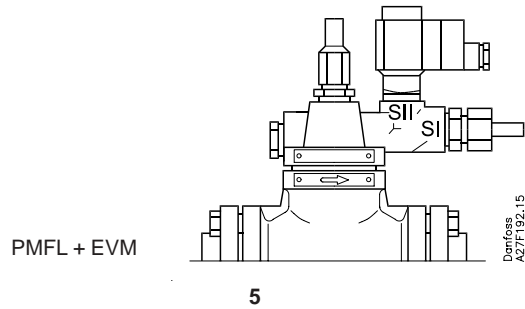
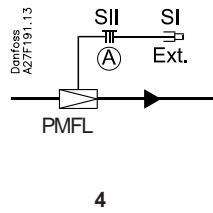
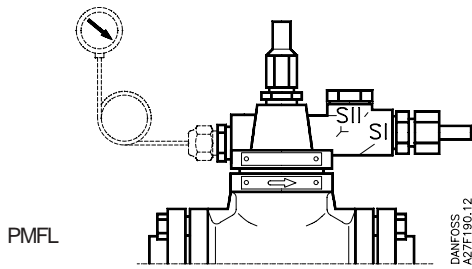
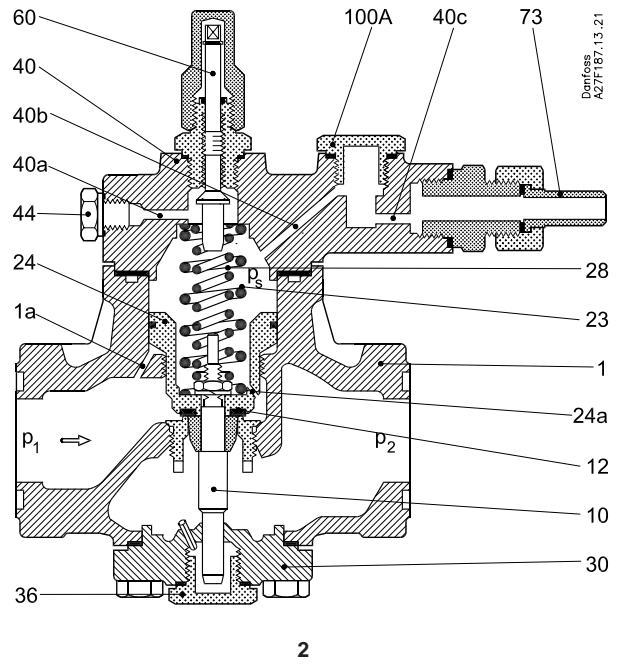
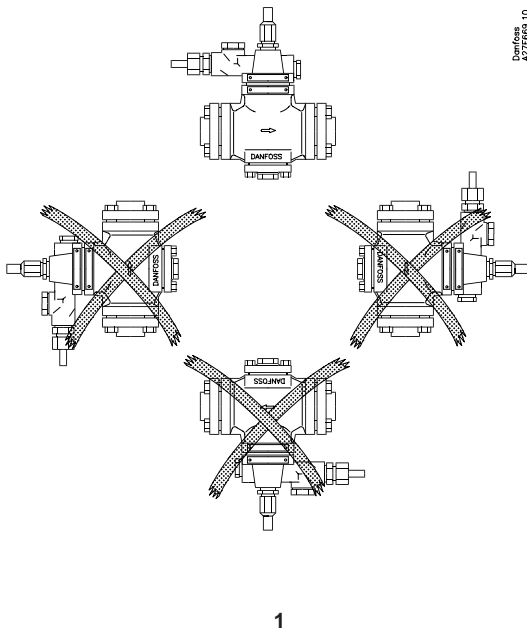
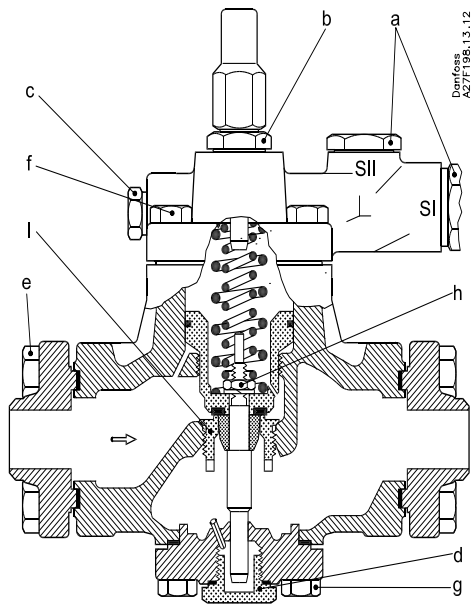

Table I

Pos. Item.	Tilspændingsmoment i Nm (10 Nm = 1 kpm) Tightening torque in Nm (1 Nm = 0.74 lb force ft) Anzugsmoment in Nm (10 Nm = 1 kpm) Couple de serrage en Nm (10 Nm = 1 kgf.m)			
	PMFL Størrelse Size Größe Dimension			
	80-1...7	125	200	300
a	50			
b	50			
c	25			
d	50			
e	60			80
f	35		60	
g	35		60	
h	17	34		
i	80	120	150	

Installation

Refrigerants

Applicable to all common non-flammable refrigerants, including R717 and non-corrosive gases/liquids dependent on sealing material compatibility.

Flammable hydrocarbons are not recommended. The valve is only recommended for use in closed circuits. For further information please contact Danfoss.

Temperature range

PMFL: -60/+120°C (-76/+248°F)

Pressure range

PMFL: The valves are designed for a max. working pressure of 28 bar g (406 psi g).

Technical data

PMFL can be used in suction, liquid, hot-gas and liquid/vapour lines. The PMFL regulates the flow of the medium by two step on/off function, depending on the control impulse from the screwed-on pilot valves.

Design

See fig. 2

1. Valve body
- 1a. Channel in valve body 1
10. Valve spindle
12. Valve plate
23. Main spring
24. Servo piston
- 24a. Channel in servo piston 24
28. Supplementary spring
30. Bottom cover
36. Drain plug
40. Cover
- 40a. b. c. Channels in cover 40
44. Pressure gauge connection
60. Manual operating spindle
73. Pilot connection
- 100A. Blanking plug

Installation

Flange set for the PMFL is delivered separately. The valve must be installed with the arrow in the direction of the flow and the top cover upwards (fig. 1). The top cover can be rotated 4 X 90° in relation to the valve body.

The valve is fitted with a spindle for manual opening.

When an external pilot valve is used, the pilot line must be connected to the upper side of the main line so that any dirt and oil from the plant will not find its way into the pilot line.

The PMFL valve can be controlled by the SV float valve as shown in fig. 7. Please refer to SV instruction guidelines.

The valve is designed to withstand a high internal pressure. However, the piping system should be designed to avoid liquid traps and reduce the risk of hydraulic pressure caused by thermal expansion. It must be ensured that the valve is protected from pressure transients like "liquid hammer" in the system.

Welding

If using welding flanges, only materials and welding methods, compatible with the flange material must be welded to the flanges. The flanges should be cleaned internally to remove welding debris on completion of welding and before the valve is inserted.

The valve housing and flanges must be free from stresses (external loads) after installation.

PMFL valves must not be mounted in systems where the outlet side of the valve is open to atmosphere. The outlet side of the valve must always be connected to the system or properly capped off, for example with a welded-on end plate.

Colours and identification

The PMFL valves are Zinc-Chromated in the factory. If further corrosion protection is required, the valves can be painted. Precise identification of the valve is made via the ID plate on the top cover. The external surface of the valve housing must be prevented against corrosion with a suitable protective coating after installation and assembly.

Protection of the ID plate when repainting the valve is recommended.

Maintenance

Service

The PMFL valves are easy to dismantle and most of its parts are replaceable. When the bottom cover is removed, the strainer can be taken out for cleaning. Do not open the valve while the valve is still under pressure.

- Check that the O-ring or gaskets have not been damaged.
- Check that the spindle is free of scratches and impact marks.
- If the teflon ring has been damaged, the parts must be replaced.

Assembly

Remove any dirt from the body before the valve is assembled. Check that all channels in the valve are not blocked with particles or similar.

Tightening

Tightening torques

See fig. 3 and table 1.

Use only original Danfoss parts, including packing glands, O-rings and gaskets for replacement. Materials of new parts are certified for the relevant refrigerant.

In cases of doubt, please contact Danfoss.

Danfoss accepts no responsibility for errors and omissions. Danfoss Industrial Refrigeration reserves the right to make changes to products and specifications without prior notice.

DECLARATION OF CONFORMITY
The Pressure Equipment Directive 97/23/EC



Name and Address of Manufacturer within the European Community

Danfoss Industrial Refrigeration A/S
Stormosevej 10
PO Box 60
DK-8361 Hasselager
Denmark

Description of Pressure Equipment

Refrigerant main regulating valves
Type PM, PML, PMLX, PMFH, PMFL, MRV, MEV

Nominal bore	DN32-150 mm (1 ¹ / ₄ - 6 in.)	
Classified for	Fluid Group I (all refrigerants (toxic, nontoxic, flammable and nonflammable)). For further details / restrictions - see Installation Instruction.	
Temperature range	All	-60°C (-76°F) to 120°C (248°F)
Maximum allowable working pressure		28 bar (406 psi)

Conformity and Assessment Procedure Followed

Category	II	III
Module	D1	B1+D
Certificate ID	D1: 07 202 0511 Z 0009/1/H-0002	B1: 07 202 0511 Z 0074/1/H-0001 D: 07 202 0511 Z 0009/1/H-0001
Nominal bore	DN 32-125 mm (1 ¹ / ₄ -5 in)	DN150 mm (6 in)

Name and Address of the Notified Body which carried out the Inspection

TÜV-Nord e.V.
Grosse Bahnstrasse 31
22525 Hamburg, Germany



Name and Address of the Notified Body monitoring the Manufacturer's Quality Assurance System

TÜV-Nord e.V.
Grosse Bahnstrasse 31
22525 Hamburg, Germany

References of Harmonised Standards used

References of other Technical Standards and Specifications used

prEN 12284 DIN 3158
EN 1563 AD-Merkblätter

Authorised Person for the Manufacturer within the European Community

Name: Morten Steen Hansen **Title:** Production Manager

Signature: Morten Steen Hansen **Date:** 14/08/2002