

CI-tronic™ single-phase compressor soft starter  
Type TCI 25C



Introduction



The TCI 25C soft starter is designed for soft starting of single-phase compressors. During start the TCI 25C will gradually ramp-up the motor voltage to full line voltage thus reducing the starting current peak.

Features

- Easy installation between normal motor starter and motor
- LED status indication
- Unlimited start/stop operation per hour
- DIN rail mountable
- Starting time max. 0,5 seconds
- Suitable for 50/60 Hz
- EN 60947-4-2

Ordering guide

Line Voltage	Motor Current	Motor Power	Type	Code No.
220-240 V a.c.	25 A max.	4 kW / 5,5 HP	TCI 25C	037N0086

Technical Data

*Output specifications*

Operational voltage	220-240 V a.c.
Operational current (AC 3, AC 53a)	25 A max. (50 mA min.)
Semiconductor protection fusing	
Type 1 co-ordination:	100 A gL/gG
Type 2 co-ordination:	6300 A <sup>2</sup> s

*Control specifications*

EMC immunity	Meets EN 60947-4-2
--------------	--------------------

*Start profile*

Ramp-up time	0,5 seconds (max.)
Starting torque	50% of nominal starting torque

*Insulation specifications*

Rated insulation voltage, $U_i$	660 V
Rated impulse withstand voltage $U_{imp}$	4 kV
Installation category	III

*Thermal specifications, environment*

Power dissipation, continuously duty	1 W/A
Power dissipation, intermittent duty	1 W/A x duty cycle
Operating temperature range	-5°C to 40°C
Cooling method	Natural convection

**Technical Data**  
(continued)

*Materials*

Housing	Self extinguishing PPO UL94V1
Heat sink	Aluminium black anodised
Base	Electroplated steel

**Functional description**

As soon as the TCI 25C is connected to mains voltage a motor soft start is performed. The balanced ramp-up time and starting voltage (initial torque) ensures a fast and

reliable start. TCI 25C can be used for single phase motors with and without a start capacitor, - see wiring examples.

**Functional diagram**

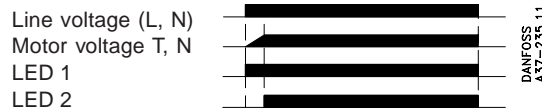

**Wiring examples**

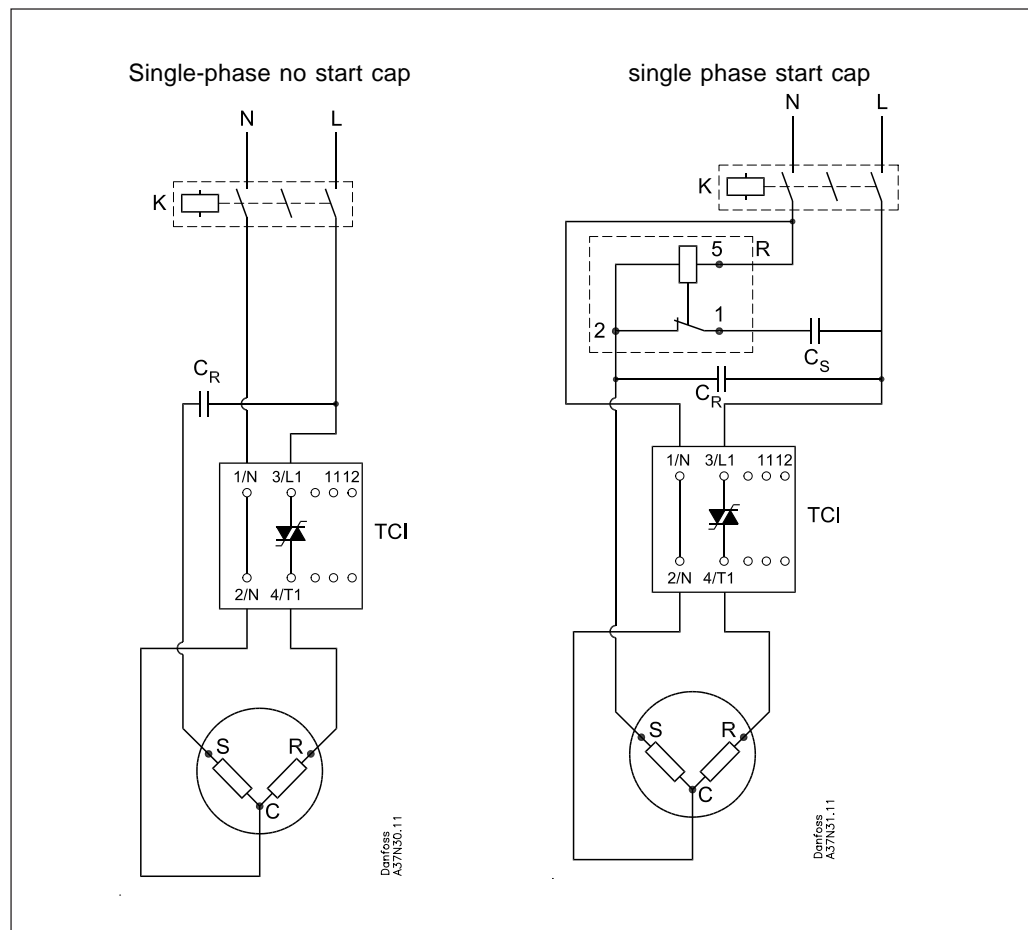

For selection of capicotos and start relay, please refer to recommendations from the compressor manufacturer

**Operating at high temperatures**

If the ambient temperature exceeds 40°C the current must be de-rated according to table below.

Ambient temperature	Continuous current	Intermittent current (max. 15 min. ON-time)
50°C	23 A	25 A (max. duty cycle 0,8)
60°C	15 A	25 A (max. duty cycle 0,65)

**Overheat protection**

If required the controller can be protected against overheating by inserting a thermostat in the slot on the right-hand side of the controller. Order: UP 62 thermostat 037N0050

The thermostat is connected in series with the control circuit of the main contactor. When the temperature of the heat sink exceeds 100°C the main contactor will be switched OFF. A manual reset is necessary to restart this circuit.

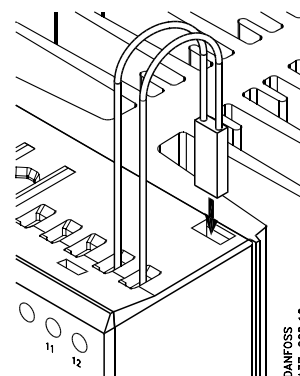

**Mounting instructions**

The controller is designed for vertical mounting. If the controller is mounted horizontally the load current must be reduced by 50%. The controller needs no side clearance. Clearance between two vertical mounted controllers must be minimum 80 mm (3.15"). Clearance between controller and top and bottom walls must be minimum 30 mm (1.2").

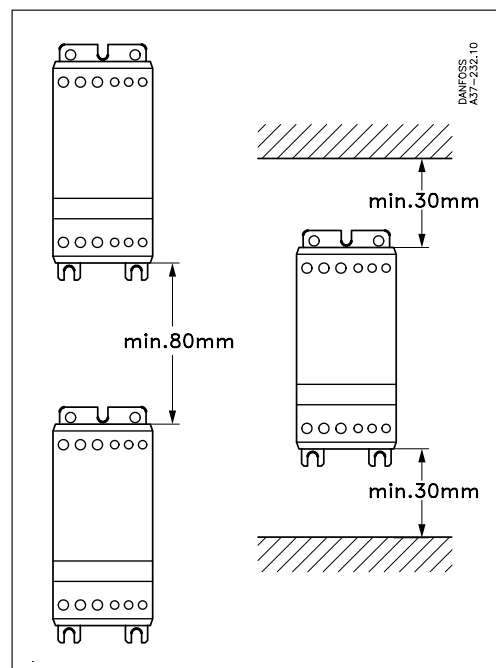

Dimensions

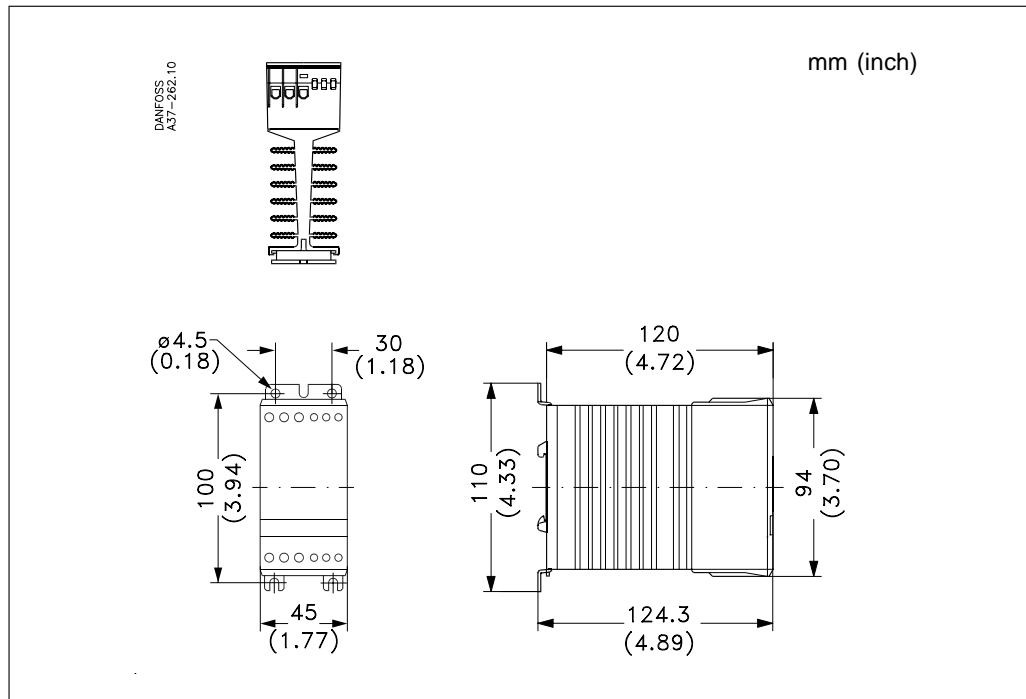



---

Danfoss can accept no responsibility for possible errors in catalogues, brochures and other printed material. Danfoss reserves the right to alter its products without notice. This also applies to products already on order provided that such alterations can be made without subsequential changes being necessary in specifications already agreed. All trademarks in this material are property of the respective companies. Danfoss and the Danfoss logotype are trademarks of Danfoss A/S. All rights reserved.

---