

---

CI-tronic™ Analogue Power Controller  
Type ACI 30-1 and ACI 50-1



Introduction



The versatile ACI analogue power controller is designed for very precise temperature and transformer control. Due to the built-in microprocessor the controller can operate in phase angle as well as in burst firing control mode.

The controller automatically adapts to the load to ensure a smooth inrush, and in burst firing mode it will further eliminate the unwanted

effects of DC magnetizing on transformers. The ACI unit is easily connected to a PLC/regulator by means of one of the selectable input signals.

The analogue controller ACI is typically used as controller for heaters and infrared lamps but also ideal on transformer controlled processes.

Features

- Phase angle or burst firing control mode
- Current loop control, 4-20 mA, 20-4 mA, 0-20 mA and 20-0 mA
- Voltage control, 0-10 V d.c. and 10-0 V d.c.
- Potentiometer control, 0-10 kΩ and 10-0 kΩ
- Rated operational voltage, 230 and 480 V
- Control voltage, 19-28 V a.c./d.c.
- DIN-rail mountable
- Built-in varistor protection
- LED status identification
- IP 20 protection
- Compact modular design
- Easy and quick installation
- Specification acc. to industrial standard
- CE, CSA, UL and C-tick

Selection guide

| Operational voltage<br>V a.c. | Operational current max.<br>A | Supply voltage<br>V a.c. / d.c. | Dimensions<br>mm | Type     | Code no.        |
|-------------------------------|-------------------------------|---------------------------------|------------------|----------|-----------------|
| 230                           | 30                            | 19-28                           | 45               | ACI 30-1 | <b>037N0057</b> |
| 400-480                       | 30                            | 19-28                           | 45               | ACI 30-1 | <b>037N0059</b> |
| 230                           | 50                            | 19-28                           | 90               | ACI 50-1 | <b>037N0058</b> |
| 400-480                       | 50                            | 19-28                           | 90               | ACI 50-1 | <b>037N0060</b> |

Technical data

| Output specifications                              | ACI 30-1  | ACI 50-1 |
|--|---|----------|
| Operational current max. AC-51 (heater load)       | 30 A  | 50 A     |
| Operational current max. AC-56a (transformer load) | 30 A  | 30 A     |
| Operational voltage 50/60 Hz                       | 230 V / 480 V   |          |
| Leakage current max.                               | 1 mA  |          |
| Operational current min.                           | 10 mA   |          |
| <i>Control method</i>                              |   |          |
| Phase angle control                                | Selectable linear power or linear voltage                                 |          |
| Burst firing control                               | Selectable cycle time : 0.4 - 60 seconds                                  |          |
| <i>Semiconductor protection fusing</i>             |   |          |
| Type 1 co-ordination                               | 50 A gL/gG  |          |
| Type 2 co-ordination I <sup>2</sup> t(t=10 ms)     | 1800 A <sup>2</sup> s   |          |
| <i>Control circuit specifications</i>              |   |          |
| Control supply voltage                             | 19-28 V a.c./d.c.   |          |
| <i>Control signals</i>                             |   |          |
| Current loop control (voltage drop < 3 V)          | 4-20 mA, 20-4 mA, 0-20 mA and 20-0 mA                                     |          |
| Voltage control (input resistance > 300 kΩ)        | 0-10 V d.c. and 10-0 V d.c.   |          |
| Potentiometer control                              | 0-10 kΩ and 10-0kΩ  |          |
| <i>Isolation</i>                                   |   |          |
| Control input                                      | Floating control input  |          |
| Voltage line to control                            | 2.5 kV a.c.   |          |
| Voltage supply to control                          | 500 V a.c.  |          |
| Protection   | Supply and control inputs are protected against overload and over voltage |          |
| EMC immunity                                       | Meets requirements of EN 50082-1 and EN 50082-2                           |          |
| <i>Insulation</i>                                  |   |          |
| Rated insulation voltage, U <sub>i</sub>           | 660 V   |          |
| Rated impulse withstand voltage, U <sub>imp</sub>  | 4 kV  |          |
| Installation category                              | III   |          |
| <i>Thermal specification</i>                       |   |          |
| Power dissipation, continuous duty                 | 1.2 W/A   |          |
| Power dissipation, intermittent duty               | 1.2 W/A x duty cycle  |          |
| Ambient temperature range                          | -5°C to 40°C  |          |
| Cooling method                                     | Natural convection  |          |
| Mounting   | Vertical (see general mounting instructions)                              |          |
| Max. ambient temperature with limited current      | 60°C, see derating for high temperatures in chart below                   |          |
| Storage temperature range                          | -20°C to 80°C   |          |
| Protection degree/ pollution degree                | IP20/ 3   |          |
| <i>Material</i>                                    |   |          |
| Housing  | Self extinguishing PPO UL 94V1  |          |
| Heatsink   | Aluminium black anodised  |          |
| Base   | Electroplated steel   |          |

Operating at high temperature

| Ambient temperature | ACI 30 | ACI 50 |
|---------------------|--------|--------|
| 40°C                | 30A    | 50A    |
| 50°C                | 25 A   | 40 A   |
| 60°C                | 20 A   | 30 A   |

**Control mode selection**

**Selection of control signal**

The type of control signal, current, voltage or potentiometer can be selected on the rotary switch.

**Protection**

The control input is protected against overload. If the current exceeds 25 mA, the loop will switch OFF and the LEDs will indicate failure. The input will not be damaged if the 24 V supply by mistake is connected to the signal input. Control input terminals are marked with + and -. Correct polarity must be observed. The control input is floating.

**Insulation voltage**

Line voltage to control: 2500 V a.c.  
Supply to control: 500 V a.c.

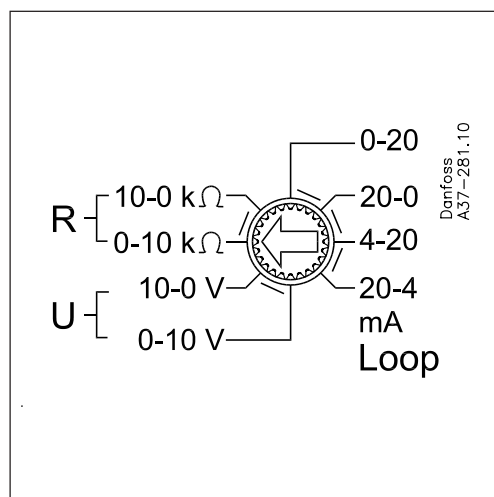

**Function mode selection**

**Phase angle**

Phase angle control is used for control of infrared lamps or heaters in IR heating applications. **Two different operation modes can be selected**

Linear voltage: The load voltage varies linearly with the control signal.

Linear power: The power delivered to the load varies linearly with the control signal.

**Burst firing**

In burst firing mode full sine waves are supplied to the load. Consequently DC magnetizing of the supply transformer is avoided. The number of sine waves varies linearly with the control signal. Adjustable cycle times from 400 ms to 60 sec.

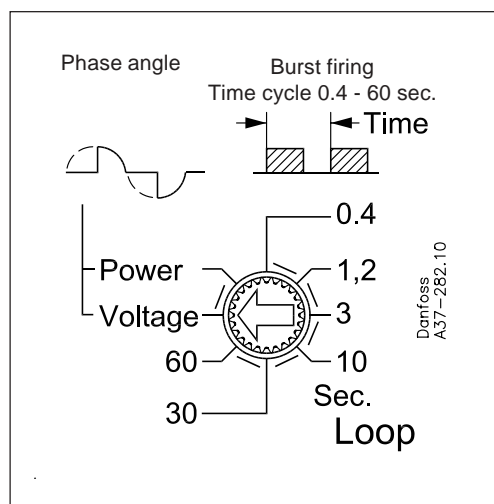

**Wiring**

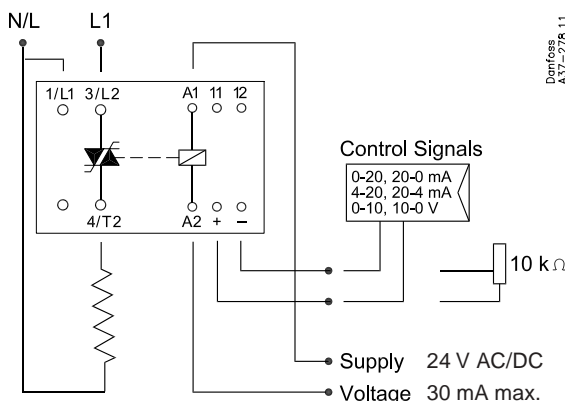

**Applications  
(heater load)**

Single-phase 230 V a.c. (400 V a.c.)  
Phase angle and burst firing mode

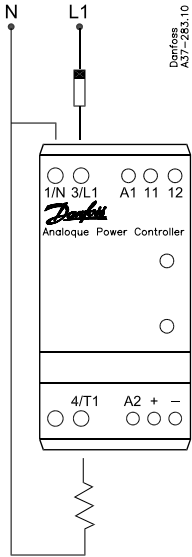

|               |         |       |
|---------------|---------|-------|
| Max. load at: | 230 V   | 400 V |
| ACI 30-1      | 6.9 kW  | 12 kW |
| ACI 50-1      | 11.5 kW | 20 kW |

Three-phase with neutral  
Phase angle and burst firing mode

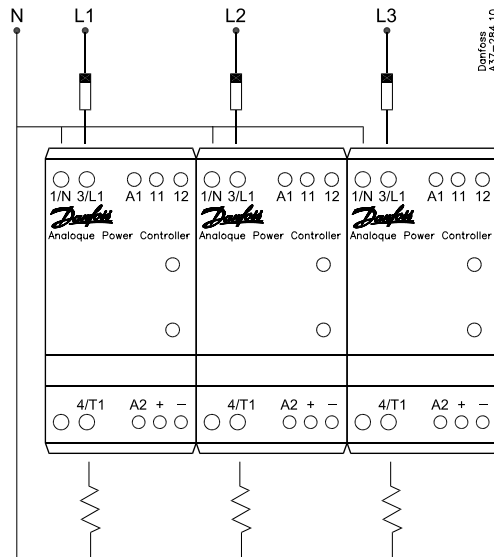

|               |         |
|---------------|---------|
| Max. load at: | 230 V   |
| 3 x ACI 30-1  | 20.7 kW |
| 3 x ACI 50-1  | 24.5 kW |

Three phase with single-phase  
contactor ECI-1 as slave  
Only burst firing mode

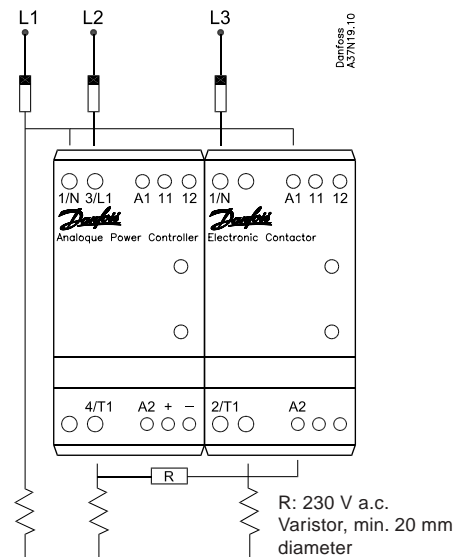

|                     |         |
|---------------------|---------|
| Max. load at:       | 400 V   |
| ACI 30-1 + ECI 30-1 | 20.7 kW |
| ACI 50-1 + ECI 50-1 | 34.1 kW |

**Application  
(transformer loads)**

**Transformer loads**

ACI load driving capability includes transformer applications which means that low voltage loads can be controlled via an isolation transformer without any surge or DC magnetising of the transformer.

**Switching transformers**

The problem in transformer switching is the magnetic circuit. When the transformer is switched off, (H=0) the field (B) remains on a high level due to the high remanence of modern transformer core material. At initial turn-on where the remanence is unknown the ACI will soft start to avoid the high current surge and at repetitive turn-on the switch-off polarity is "remembered" so next turn-on will be in the opposite polarity, thereby eliminating the high current surge normally seen in transformer applications. DC magnetising is eliminated by operating in full cycle mode only.

**Phase angle mode**

An initial turn on ACI will soft start the transformer to the voltage level set by the analogue input.

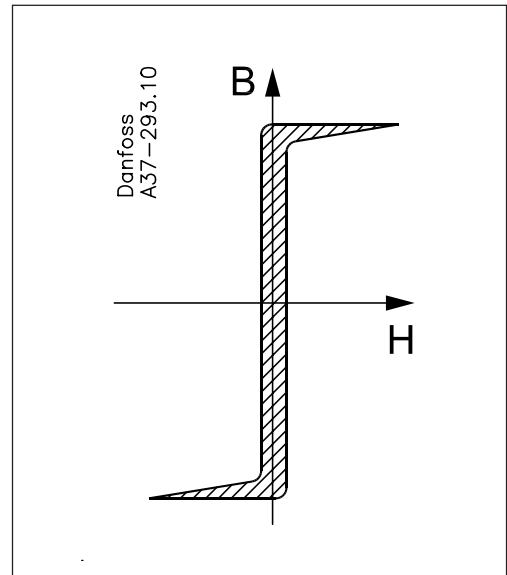

**Burst firing mode**

An initial turn on ACI will soft start the transformer to full on mode. The controller will only allow full cycles to be supplied to the transformer hereby eliminating current surges and DC saturation of the transformer

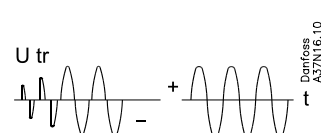
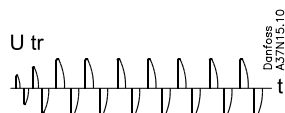

**Applications  
(transformer loads)**

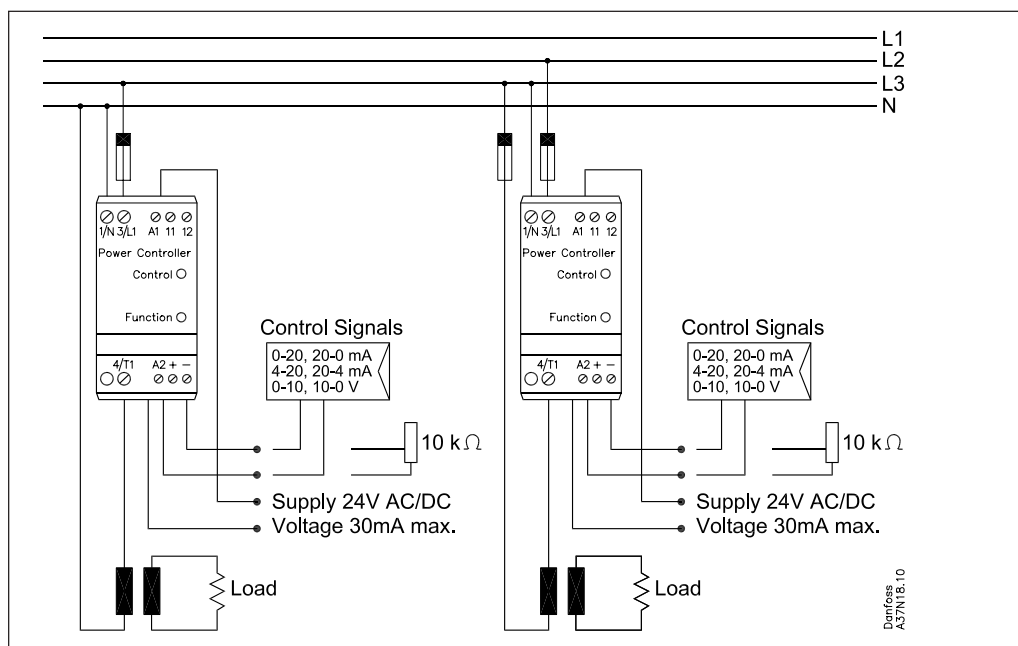

Danfoss  
A37N18.10

**Overhead protection**

If required the power controller can be protected against overheating by inserting a thermostat in the slot on the right-hand side of the controller.

Order: UP 62 thermostat 037N0050

The thermostat is connected in series with the control circuit of the main contactor. When the temperature of the heat sink exceeds 100°C the main contactor will be switched OFF. A manual reset is necessary to restart this circuit.

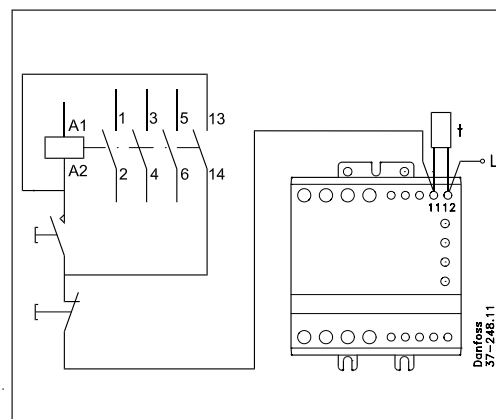

Danfoss  
37-248.11

**EMC specification**

The power controller ACI is in conformity with the standard IEC/EN 60947-4-3 AC Semiconductor Controllers and Contactors for non motor loads.

**Burst firing control mode:**

No action necessary

**Phase angle control mode:**

I < 10 A, no action necessary

I > 10 A, connect 1uF capacitor from N/L to L1 as shown above.

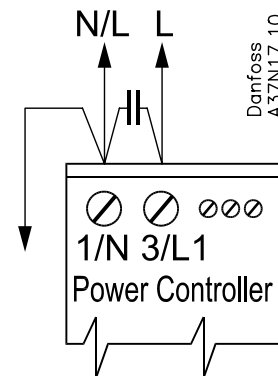

Danfoss  
A37N17.10

**Dimensions**  
mm (inch)

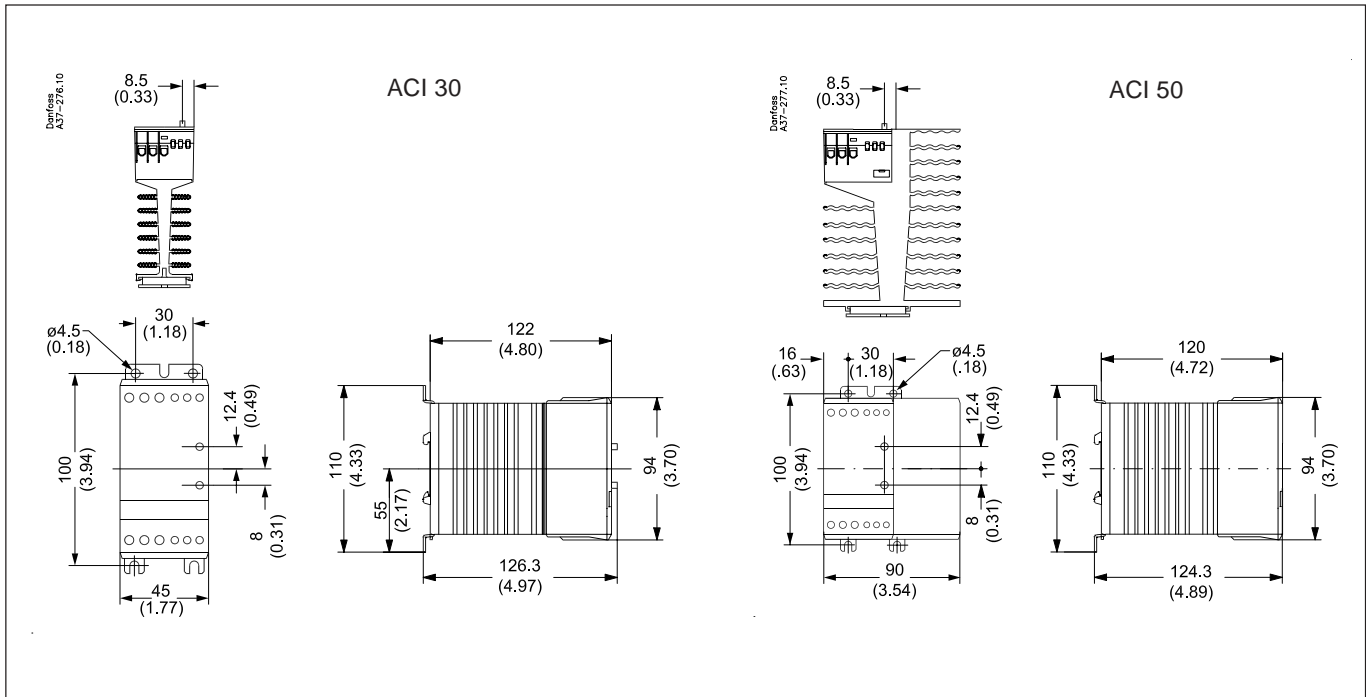

**Mounting instruction**

The controller is designed for vertical mounting. If the controller is mounted horizontally, the load current must be reduced by 50%.

The controller needs no side clearance.

Clearance between two vertical mounted controls must be minimum 80 mm (3.15").

Clearance between controller and top and bottom walls must be minimum 30 mm (1.2").

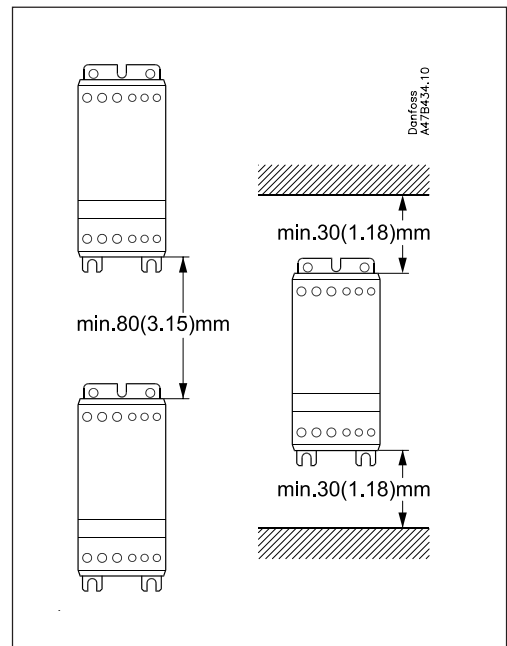

Danfoss can accept no responsibility for possible errors in catalogues, brochures and other printed material. Danfoss reserves the right to alter its products without notice. This also applies to products already on order provided that such alterations can be made without subsequential changes being necessary in specifications already agreed. All trademarks in this material are property of the respective companies. Danfoss and the Danfoss logotype are trademarks of Danfoss A/S. All rights reserved.