

---

CI-tronic™ Starting Torque Limiter  
TCI (Soft Start)



Introduction



Starting Torque Limiters are designed for the soft starting of single and three phase AC motors.

The controller allows smooth starting of all AC induction motors thus eliminating the damaging effects of high starting torque surges.

The TCI controller is easily installed between a standard motor starter and the motor, and features adjustable ramp-up time and initial torque.

Typical applications are conveyors, fans, compressors etc.

Features

- Ramp-Up time adjustable from 0.5 to 5 sec.
- Initial torque adjustable up to 85%
- Single and three phase operation
- LED Status indication.
- Unlimited start/stop operations per hour
- IP 20 Protection
- Compact modular design
- DIN rail mountable
- EN 60947-4-2
- CE, CSA, NRTL/C and C-tick

Adjustments

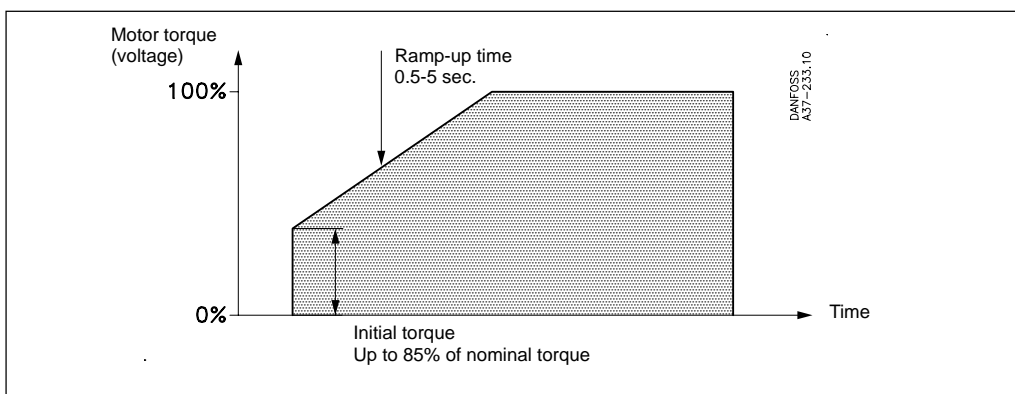

Selection Guide

Operational Voltage V a.c.	Motor current max.	Motor power max.	Dimensions	Type	Code No.
208 - 240	15 A	4.0 kW / 5.5 HP	45 mm module	TCI 15	037N0045
	25 A	7.5 kW / 10 HP	45 mm module	TCI 25	037N0046
400 - 480	15 A	7.5 kW / 10 HP	45 mm module	TCI 15	037N0045
	25A	11 kW / 15 HP	45 mm module	TCI 25	037N0046
480 - 600	15 A	7.5 kW / 10 HP	45 mm module	TCI 15	037N0047
	25 A	18.5 kW / 25 HP	45 mm module	TCI 25	037N0048
690 V AC <sup>1</sup>	25 A	18.5 kW / 25 HP	45 mm module	TCI 25	037N0049

1) 037N0049 for 690 V a.c is not CSA and NRTL/C approved

Technical Data

Control Circuit Specifications	TCI 15	TCI 25
Operational current AC 3, AC 53a and AC 58a (motor load)	15 A	25 A
Motor size at: 208 - 240 V a.c. 400 - 480 V a.c. 480 - 600 V a.c.	0.1-4.0 kW (0.18-5 HP) 0.1-7,5 kW (0.18-10 HP) 0.1-7.5 kW (0.18-10 HP)	0.1-7,5 kW (0.18-10 HP) 0.1-11 kW (0.18-15 HP) 0.1-18kW (0.18-25 HP)
Minimum operational current	50 mA	
Overload current profile	X-Tx: 8-3	
Overload relay trip class	Class 10	
Semiconductor protection fusing type 1 co-ordination type 2 co-ordination $I^2t(t = 10 \text{ ms})$	50 A gL/gG 1800 A <sup>2</sup> s	100 A gL/gG 6300 A <sup>2</sup> s

Control specifications

Ramp-up time	Adjustable from 0,5-5 seconds
Initial torque	Adjustable from 0-85% of nominal torque
EMC immunity	meets requirements of EN50082-1 and EN 50082-2

Insulation specifications

Rated insulation voltage, U <sub>i</sub>	660 V
Rated impulse withstand voltage, U <sub>imp</sub>	4 KV
Installation category	III

Thermal specifications and environment

Power dissipation, continuously duty	1 W/A
Power dissipation, intermittent duty	1 W/A. x duty cycle
Operating temperature range	-5°C to 40°C
Cooling method	Natural convection
Mounting	Vertical (see also general mounting instructions)
Max. temperature with limited current	60°C, see derating for high temperatures in chart below
Storage temperature range	-20°C to 80°C
Protection degree / pollution degree	IP 20 / 3

Materials

Housing	Self extinguishing PPO UL94V1
Heat sink	Aluminum black anodized
Base	Electroplated steel

Functional diagram

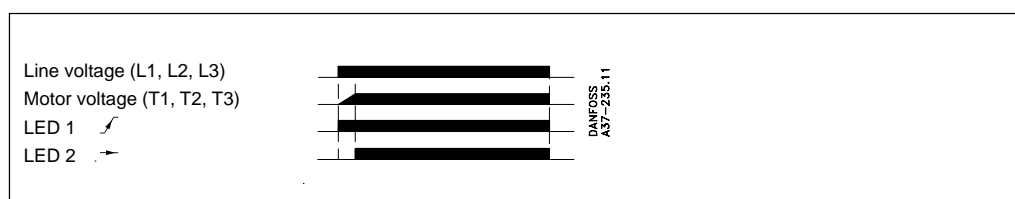

Soft start function

As soon as the TCI controller is connected to mains voltage, it soft starts the motor according to the settings.

Ramp up

During ramp up, the controller will gradually increase the voltage to the motor until it reaches full line voltage. The motors speed will depend on the actual load on the motor.

A motor with little or no load will reach full speed before the voltage has reached its maximum value.

Initial torque

The initial torque is used to set the initial starting voltage. This way it is possible to adapt the controller to an application requiring a higher starting torque.

Wiring

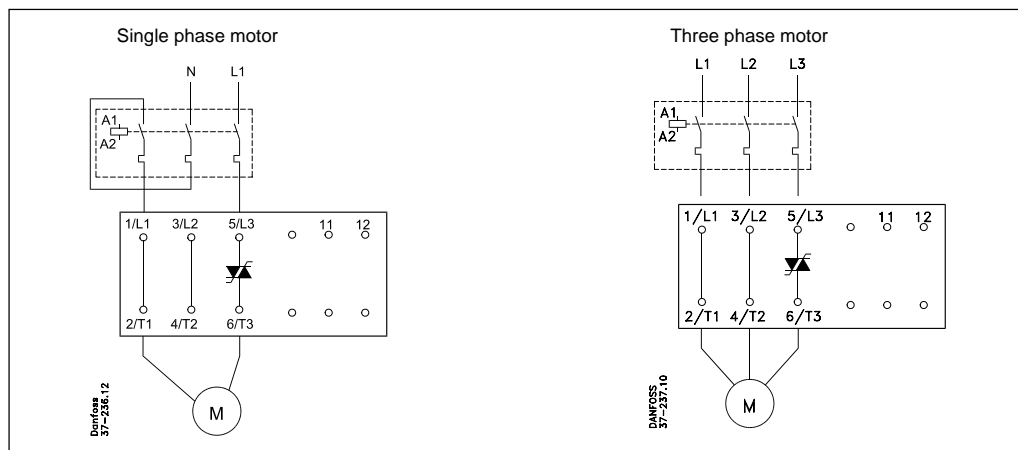

Overload and Short Circuit Protection

Overload and short circuit protection is easily achieved by installing a circuit breaker on the line side of the motor controller. Select the circuit breaker from the table according to motor full load current.

Be aware of the maximum prospective short circuit current breaking capacity. For further information please refer to the data sheet on the circuit breaker.

380 - 415 V a.c.				
Soft start type	Motor full load current in A	Danfoss CTI 25	Max. prospective short-circuit current I <sub>cc</sub> Co-ordination 1	Co-ordination 2
TCI 15	0.10 - 0.16	047B3020	50 kA	50 kA
	0.16 - 0.25	047B3021	50 kA	50 kA
	0.25 - 0.40	047B3022	50 kA	50 kA
	0.40 - 0.63	047B3023	50 kA	50 kA
	0.63 - 1.0	047B3024	50 kA	50 kA
	1.0 - 1.63	047B3025	50 kA	50 kA
	1.6 - 2.5	047B3026	50 kA	50 kA
	2.5 - 4.0	047B3027	50 kA	50 kA
	4 - 6	047B3028	50 kA	50 kA
TCI 25	6 - 10	047B3029	50 kA	10 kA
	10 - 16	047B3030	10 kA	5 kA
	16 - 20	047B3031	8 kA	3 kA
	20 - 25	047B3032	8 kA	3 kA

Dimensions mm (inch)

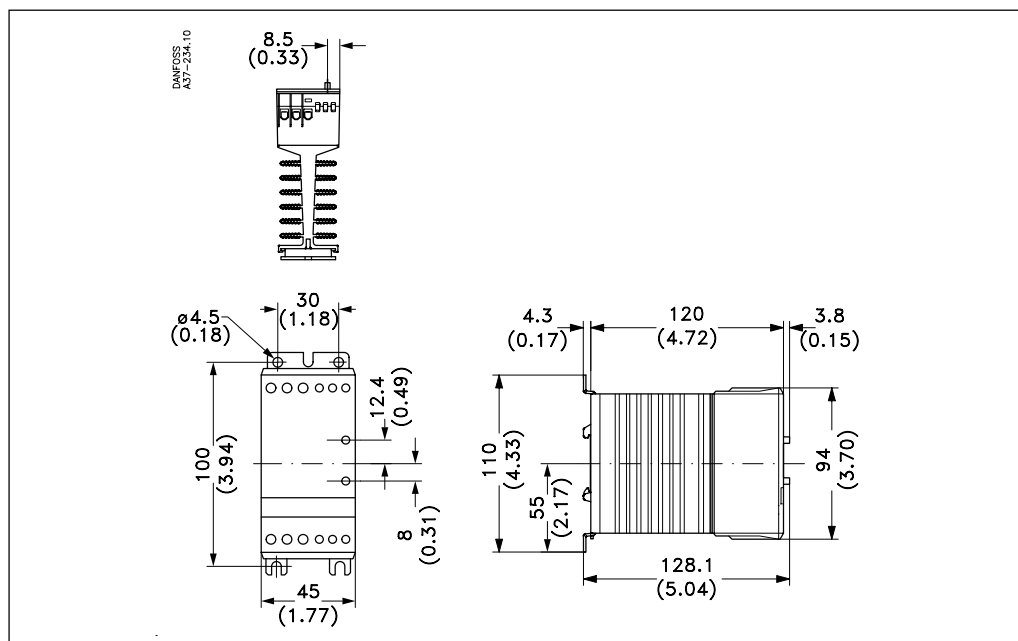

**Operating at high temperatures**

If the ambient temperature exceeds 40°C the current must be derated according to table.

Ambient temperature	Continues current		Duty-cycle rating (15 min. max. on-time)	
	TCI 15	TCI 25	TCI 15	TCI 25
50°C	15 A	25 A	15 A, 100% duty-cycle	25 A, 100% duty-cycle
60°C	15 A	20 A	15 A, 100% duty-cycle	25 A, 80% duty-cycle

**Overheat protection**

If required the controller can be protected against overheating by inserting a thermostat in the slot on the right-hand side of the controller.

Order: UP 62 thermostat 037N0050

The thermostat is connected in series with the control circuit of the main contactor. When the temperature of the heat sink exceeds 100°C the main contactor will be switched OFF. A manual reset is necessary to restart this circuit.

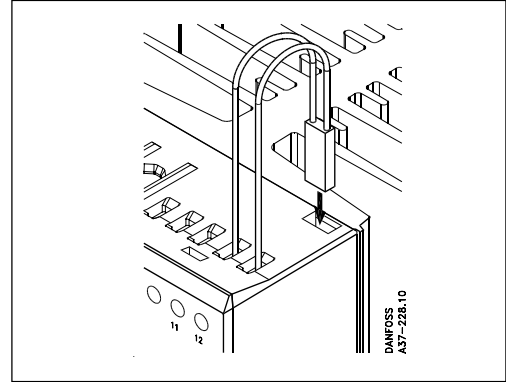

**Mounting instructions**

The controller is designed for vertical mounting. If the controller is mounted horizontally the load current must be reduced by 50%.

The controller needs no side clearance.

Clearance between two vertical mounted controller must be minimum 80 mm (3.15").

Clearance between controller and top and bottom walls must be minimum 30 mm (1.2").

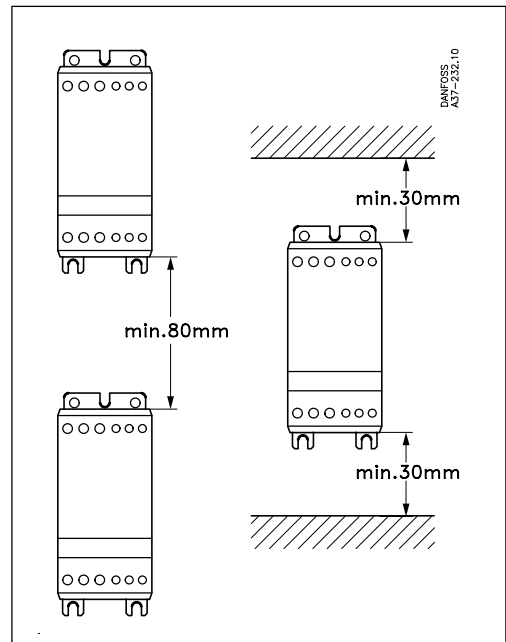



---

Danfoss can accept no responsibility for possible errors in catalogues, brochures and other printed material. Danfoss reserves the right to alter its products without notice. This also applies to products already on order provided that such alterations can be made without subsequential changes being necessary in specifications already agreed. All trademarks in this material are property of the respective companies. Danfoss and the Danfoss logotype are trademarks of Danfoss A/S. All rights reserved.

---