

Thermostats  
RT14E, RT101E, RT107E, RT123E

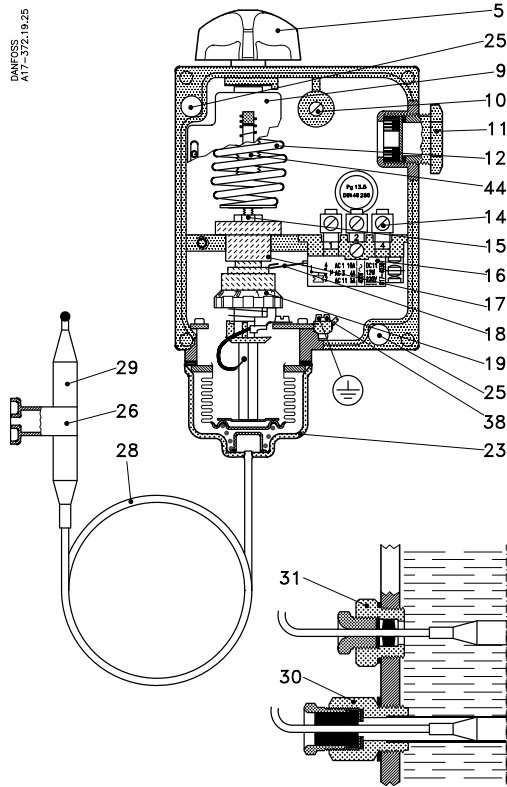

Fig. 1

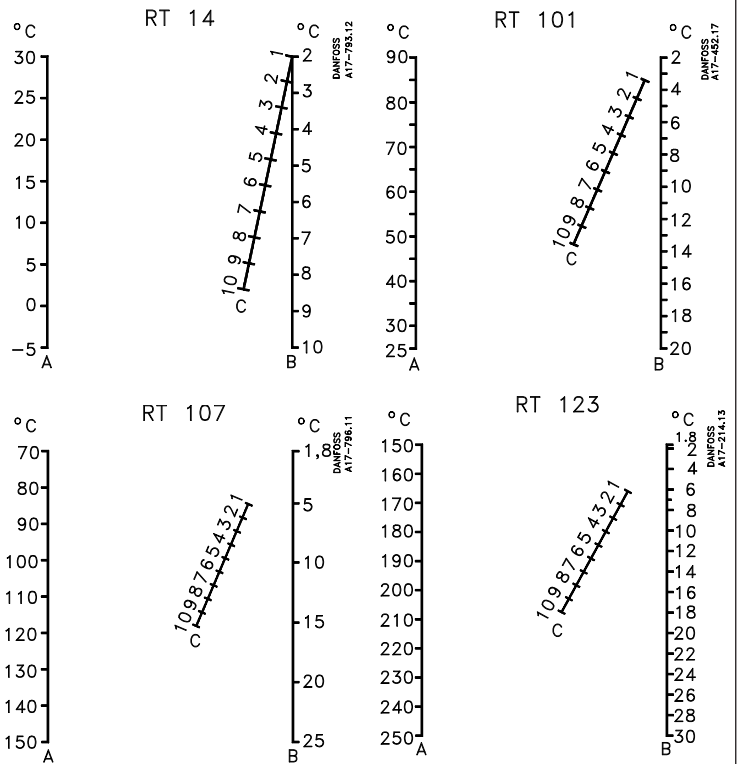

Fig. 2

A: Range setting  
B: Differential obtained  
C: Differential setting

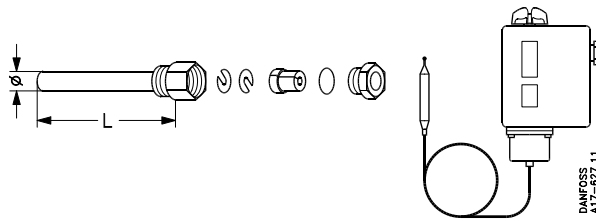

Fig. 3

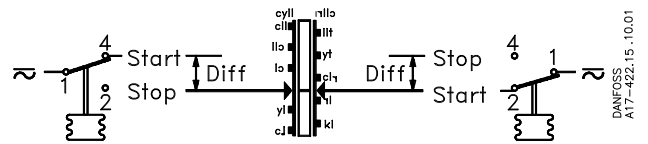

Fig. 4

Product marking

0539 II2G  
**DEMKO 05 ATEX 135385X**  
**EEx ia IIC T5**      $-20^{\circ}\text{C} \leq T_a \leq 65^{\circ}\text{C}$   
**U<sub>i</sub> : 29V**            **L<sub>i</sub> : 0.2μH**  
**I<sub>i</sub> : 0.5A**             **C<sub>i</sub> : 0.5nF**  
**P<sub>i</sub> : 1W**

Technical data

Type	RT14E	RT101E	RT107E	RT123E
Range [°C]	-5...30	25...90	70...150	150...250
Max. permissible bulb temperature [°C]	150	300	215	300

Permissible ambient temperature: -20°C to +65°C

Intrinsically safe specification:

U<sub>i</sub> = 29V    I<sub>i</sub> = 0.5A    P<sub>i</sub> = 1W    C<sub>i</sub> = 0.5nF    L<sub>i</sub> = 0.2μH

Contact load: max. 100 mA, 30V a.c./d.c.  
min. 1 mA, 5V a.c./d.c.

## Installation

RT units can be fitted in any position. Use the mounting holes (25). With outdoor installation, the unit should be protected against rainfall. The bulb should be fixed to the wall by means of a bulb holding bracket (26). If it is desired to install the bulb in a water or brine tank, this can be done by using either a capillary stuffing box (31) or a bulb pocket (30). If bulb pocket is to be used, for correct bulb fitting see fig. 3.

## Electrical connection

See fig. 4.

START = make. STOP = break. DIFF. = differential.

Cable diameter: 6-14 mm

The earth terminal (38) should be connected to earth.

## Adjustment

Set the thermostat for minimum actuating temperature (range setting). Setting is done by rotating the knob (5), at the same time reading the main scale (9).

The differential is set by rotating the differential adjusting nut (19) according to the nomogram concerned (fig. 2).

Maximum actuating temperature is the sum of the temperature setting and the differential.

### Example:

An RT 123 is required to regulate the temperature in a drying oven. Max. temperature 188°C, min. temperature 180°C, differential 188 - 180 = 8°C.

1. Set the thermostat on 180°C with the knob (5).
2. Set the differential adjusting nut (19) on number 3 which can be found by reading off the nomogram for the RT123 in fig. 2.

In general, turning the knob automatically moves both the maximum and minimum actuating temperatures (break and make) up or down because of the fixed differential.

On the other hand, turning the differential adjusting nut only, alters the maximum actuating temperature.



## Safety requirements

- 1) The refrigeration system must always comply with European Ex installation standard, EN 60079-14, any local directive and legislation as well as any other regulation applying in the area of installation.
- 2) RT-E thermostat must be used only with reliable means of limiting the voltage and current to prevent sparks between the contact surfaces. The equipment to be used for electrical load limiting must be certified for gas group IIC. Also RT-E thermostat must be installed as a part of IIC electrical installation.
- 3) Cable and cable entries approved for the application must be used. Cables must not be in contact with sharp edges. The cable must be connected with adequate stress relief in order to prevent that pulling forces can be carried through the cable to the terminal.
- 4) The cycle frequency of the RT-E switch must be kept as low as possible to prevent fatigue failure on the bellows. The vibration level must be kept as low as possible.
- 5) It is recommended to regularly check the function of the RT-E switch.
- 6) Only apparatus designed, constructed and released by Danfoss must be used for application concerned. Danfoss can accept no responsibility in case of alterations made on the thermostats or the use of them against the instructions of Danfoss.
- 7) Any overload of the RT switch must be prevented. Overloaded or damaged apparatus must be exchanged.
- 8) Only authorised persons, who are certified in installing and maintaining refrigeration system may do the installation, maintenance and exchange of the switch.
- 9) Use only appropriate tools
- 10) Dispose of the switch in an environmentally-friendly way.
- 11) Do not use organic solvents for cleaning RT-E thermostats.