

Danfoss



Service Manual



Dear Danfoss partner,

In the field of components for burners and boilers, Danfoss offers a complete range for most oil burners on the market, right from the smallest domestic burners to the largest industrial burners. The construction of burners available today varies widely; therefore a high degree of adaptability is demanded from the individual components.

An example: The new series of BFP service pumps from Danfoss give the greatest possible flexibility where the range of functions and connections is concerned. These pumps are therefore ideal as replacement units for both older Danfoss pumps and pumps from other makers. If you would like precise details of how pump replacement can be simplified - please read on.

Danfoss will of course be pleased to help with the conversions outlined in this service manual and make the work of finding an alternative easier. In other words, we will make it as easy as possible for you to find the most suitable components and service from the comprehensive Danfoss range.

The service manual is intended as an aid in the daily routine. We therefore hope that the manual will make your work with Danfoss burner components easier so that we will be able to look forward to your continued custom.

Your Danfoss Team



Contents

1. Oil pumps		
Contents oil pump conversion	Page	3
Introduction	Page	4
Conversion Danfoss RS -> RSA	Page	7
Conversion Danfoss RSL -> BFP service	Page	8
Conversion Danfoss MSL -> BFP service	Page	10
Conversion Danfoss MS -> BFP service	Page	13
Conversion Danfoss BFP -> BFP service	Page	15
Conversion Suntec -> BFP service	Page	20
Conversion Eckerle -> BFP service	Page	25
Conversion Delta	Page	33
Dimensions / accessories / connections	Page	39
2. Oil burner controls		
Contents oil burner control conversion	Page	56
Introduction	Page	57
Conversion Older Danfoss series -> BHO	Page	58
Conversion Landis & Gyr -> BHO	Page	61
Conversion BHO -> BHO	Page	62
Dimensions / accessories	Page	63-66

3. Ignition units		
Contents Ignition unit conversion	Page	67
Introduction	Page	68
Conversion 52 L -> EBI	Page	69-70
Dimensions / accessories	Page	71-72
4. Nozzles		
EH + ES series nozzles, contents	Page	73
Introduction	Page	74
Conversion	Page	75
Ordering tables	Page	76-77
Marking / dimensions / capacity	Page	78-81
OD series nozzles		
Contents oil nozzle conversion	Page	82
Introduction	Page	83
Conversion Delavan -> Danfoss	Page	85
Conversion Fluidics -> Danfoss	Page	85
Conversion Hago -> Danfoss	Page	85
Conversion Monarch -> Danfoss	Page	85
Conversion Steinen -> Danfoss	Page	85
Nozzle markings / dimensions / capacity / reference pressure	Page	86-90
5. Oil preheaters		
Contents oil preheater conversion	Page	91
Introduction	Page	92
Danfoss standard types	Page	92
Dimensions	Page	93-94

Oil pump conversion

Contents

Introduction	Page	4
Conversion	Danfoss RS -> RSA	Page	7
Conversion	Danfoss RSL -> BFP Service	Page	8
Conversion	Danfoss MSL -> BFP Service	Page	10
Conversion	Danfoss MS -> BFP Service	Page	13
Conversion	Danfoss BFP -> BFP Service	Page	15
Conversion	Suntec -> BFP Service	Page	20
Conversion	Eckerle -> BFP Service	Page	25
Conversion	DELTA -> BFP Service	Page	33
Dimensions	RSA	Page	39
Accessories	RSA	Page	40
Dimensions	RSL, MSL, MS, BFP	Page	41
Accessories	RSL, MSL, MS, BFP	Page	51
Connections	Page	52

Oil pump conversion

The tables below give the following pump conversions:

- Danfoss RS pumps to RSA pumps
- Danfoss RSL/MSL/MS/BFP pumps to BFP service pumps
- Suntec pumps to BFP service pumps
- Eckerle pumps to BFP service pumps
- Delta pumps to BFP service pumps

Using Danfoss service pumps BFP 21 L3 and BFP 21 R3 it is possible to maintain 90% of existing small burners. In other cases it can be difficult to find the correct Danfoss service pump. The main purpose of the conversion tables is to make the replacement of such pumps easier.

The tables are compiled as follows:

- Column 1 always gives the pump type to be replaced.
- Column 2 gives the code number of the pump to be replaced.

Note: Where Eckerle pumps are concerned, column 1 gives the old and column 2 the new designation.

- Column 3 states whether the pump is for 1-pipe or 2-pipe operation.

Note: With the MS pump, the numbers "1 + 2" are shown together because this particular unit has automatic changeover. Eckerle pumps have no suffixes.

- Column 5 gives the Danfoss pump type able to replace the existing pump.
- Column 6 gives the corresponding Danfoss code number.
- The last column, »Comments/accessories«, refers to special characteristics and features. Please note that in some cases accessories are necessary.

Explanation - code number and comments:

When changing over from pumps with hydraulic shut-off valve (RSL and MSLC) to BFP with electric shut-off valve (BFP 11, 21 and 41) a cable must be ordered for connection to the motor terminals in the oil burner control.

Some pump types carry the comment "No repl.". There are several possible explanations, among them:

- The BFP service pump cannot supply the required nozzle capacity.
- The BFP service pump does not have the required coil voltage. BFP coils are only available for 220-240 V a.c., 110-120 V a.c. and 24 V a.c.
- The shaft of the BFP service pump is not of a suitable diameter.
- With the BFP service pump it is possible that a hydraulic cylinder might be

connected to the pressure gauge port on the front.

The position of connections and clockwise/counterclockwise indication are always given when looking on the shaft end. See ill. on page 6).

Before fitting a service pump, a check must be made of whether it is set for 1-pipe or 2-pipe operation. If necessary, the pump must be reset to suit the system in which it is being installed.

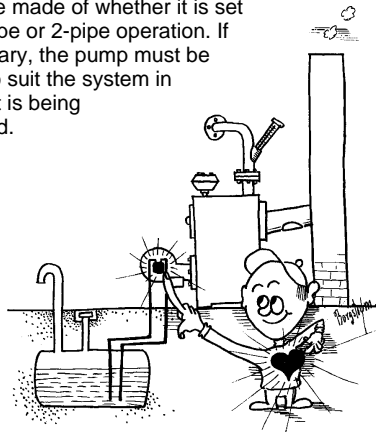

Note:

All information is given looking at the pump on its shaft end (counterclockwise/clockwise), i.e.

- Direction of shaft rotation
- Valve position
- Connections

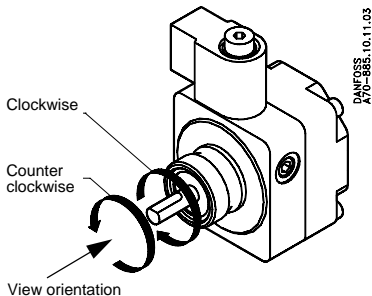

Changeover from 2-pipe to 1-pipe operation

BFP 11

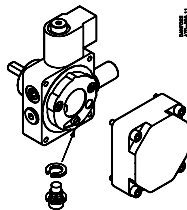

1-pipe: with horseshoe washer fitted

BFP 20 / 21 / 41

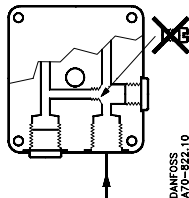

1-pipe: without screw

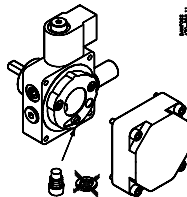

2-pipe: with horseshoe washer removed

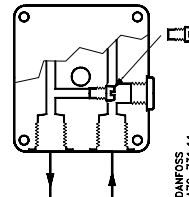

2-pipe: screw inserted

Oil pumps – Danfoss RS

Danfoss oil pumps - older series			➔	Replacement Danfoss types		
Type	Code no.	1/2-pipe	➔	Type	Code no.	Comments/accessories
RS 28	070-5300	1	➔	RSA 28	070-5370	
RS 28	070L5300	1	➔	RSA 28	070L5370	
RS 28	070-5302	2	➔	RSA 28	070-5372	
RS 28	070L5302	2	➔	RSA 28	070L5372	
RS 28	070-5310	1	➔	RSA 28	070-5380	
RS 28	070L5310	1	➔	RSA 28	070L5380	
RS 28	070-5312	2	➔	RSA 28	070-5382	
RS 28	070L5312	2	➔	RSA 28	070L5382	
RS 28	070-5322	2	➔	RSA 28	070-5332	
RS 28	070L5322	2	➔	RSA 28	070L5332	
RS 40	070-3200	1	➔	RSA 40	070-3230	
RS 40	070L3200	1	➔	RSA 40	070L3230	
RS 40	070-3202	2	➔	RSA 40	070-3232	
RS 40	070L3202	2	➔	RSA 40	070L3232	
RS 40	070-3210	1	➔	RSA 40	070-3240	
RS 40	070L3210	1	➔	RSA 40	070L3240	
RS 40	070-3212	2	➔	RSA 40	070-3242	
RS 40	070L3212	2	➔	RSA 40	070L3242	
RS 40	070-3222	2	➔	RSA 40	070-3249	
RS 40	070L3222	2	➔	RSA 40	070L3249	
RS 60	070-3300	1	➔	RSA 60	070-3350	
RS 60	070L3300	1	➔	RSA 60	070L3350	
RS 60	070-3302	2	➔	RSA 60	070-3352	
RS 60	070L3302	2	➔	RSA 60	070L3352	
RS 60	070-3310	1	➔	RSA 60	070-3360	
RS 60	070L3310	1	➔	RSA 60	070L3360	

Oil pumps – Danfoss RS

Danfoss oil pumps - older series			➔	Replacement Danfoss types		
Type	Code no.	1/2-pipe	➔	Type	Code no.	Comments/accessories
RS 60	070-3312	2	➔	RSA 60	070-3362	
RS 60	070L3312	2	➔	RSA 60	070L3362	

Oil pumps – Danfoss RSL

Danfoss oil pumps - older series			➔	Replacement Danfoss types		
Type	Code no.	1/2-pipe	➔	Type	Code no.	Comments/accessories
RSL 028	070-4330	1	➔	BFP 21 R3	071N0157 ¹⁾	
RSL 028	070L4330	1	➔	BFP 21 L3	071N0156 ⁶⁾	+ cable, L = 710 mm: 071G0204
RSL 028	070-4332	2	➔	BFP 21 R3	071N0157 ^{1) 7)}	
RSL 028	070L4332	2	➔	BFP 21 L3	071N0156 ^{6) 7)}	
RSL 028	070-4340	1	➔	BFP 21 R3	071N0157 ¹⁾	
RSL 028	070L4340	1	➔	BFP 21 L3	071N0156 ⁶⁾	+ cable, L = 710 mm: 071G0204
RSL 028	070-4342	2	➔	BFP 21 R3	071N0157 ^{1) 7)}	+ bush Ø54: 071B0011
RSL 028	070L4342	2	➔	BFP 21 L3	071N0156 ^{6) 7)}	
RSL 050	070-3130	1	➔	BFP 21 R5	071N0173 ²⁾	
RSL 050	070L3130	1	➔	BFP 21 L5	071N0172 ²⁾	+ cable, L = 710 mm: 071G0204
RSL 050	070-3132	2	➔	BFP 21 R5	071N0173 ²⁾	
RSL 050	070L3132	2	➔	BFP 21 L5	071N0172 ²⁾	
RSL 050	070-3140	1	➔	BFP 21 R5	071N0173 ²⁾	+ cable, L = 710 mm: 071G0204
RSL 050	070L3140	1	➔	RFP 21 L5	071N0172 ²⁾	+ bush Ø54: 071B0011

1) The solenoid coil must be connected in parallel with the burner motor.

2) Important: These pumps are delivered for two-pipe operation. If the pumps are mounted on a one-pipe system, the changeover screw must be removed (fig. page 6) and the return port must be stopped with a metal plug.

6) If the pump is wanted delivered incl. cable, bush and flange, please order 071N0132.

7) This pump is for one-pipe operation. On pumps for two-pipe operation the changeover screw must be fitted.

Oil pumps – Danfoss RSL

Danfoss oil pumps - older series			➔	Replacement Danfoss types		
Type	Code no.	1/2-pipe	➔	Type	Code no.	Comments/accessories
RSL 050	070-3142	2	➔	BFP 21 R5	071N0173 ²⁾	+ cable, L = 710 mm: 071G0204
RSL 050	070L3142	2	➔	BFP 21 L5	071N0172 ²⁾	+ bush Ø54: 071B0011

Oil pumps – Danfoss RSLB

Danfoss oil pumps - older series			➔	Replacement Danfoss types		
Type	Code no.	1/2-pipe	➔	Type	Code no.	Comments/accessories
RSLB 028	070-4030	1	➔	BFP 20 R3	071N0169 ²⁾	<p>Please note:</p> <p>If a BFP 20 is used on a gravity feed installation, a solenoid valve (if not existing) must be fitted in the nozzle line to ensure "shut off" on burner stop.</p> <p>If a valve is not fitted, then use a BFP 21 and wire the pump's solenoid valve into the control box.</p>
RSLB 028	070L4030	1	➔	BFP 20 L3	071N0168 ²⁾	
RSLB 028	070-4032	2	➔	BFP 20 R3	071N0169 ²⁾	
RSLB 028	070L4032	2	➔	BFP 20 L3	071N0168 ²⁾	
RSLB 028	070-4040	1	➔	BFP 20 R3	071N0169 ²⁾	
RSLB 028	070L4040	1	➔	BFP 20 L3	071N0168 ²⁾	
RSLB 028	070-4042	2	➔	BFP 20 R3	071N0169 ²⁾	
RSLB 028	070L4042	2	➔	BFP 20 L3	071N0168 ²⁾	
RSLB 050	070-4130	1	➔	BFP 20 R5	071N0129 ²⁾	
RSLB 050	070L4130	1	➔	BFP 20 L5	071N0126 ²⁾	
RSLB 050	070-4132	2	➔	BFP 20 R5	071N0129 ²⁾	
RSLB 050	070L4132	2	➔	BFP 20 L5	071N0126 ²⁾	
RSLB 050	070-4140	1	➔	BFP 20 R5	071N0129 ²⁾	
RSLB 050	070L4140	1	➔	BFP 20 L5	071N0126 ²⁾	
RSLB 050	070-4142	2	➔	BFP 20 R5	071N0129 ²⁾	
RSLB 050	070L4142	2	➔	BFP 20 L5	071N0126 ²⁾	

2) Important: These pumps are delivered for two-pipe operation. If the pumps are mounted on a one-pipe system, the changeover screw must be removed (fig. page 6) and the return port must be stopped with a metal plug.

Oil pumps – Danfoss MSLA

Danfoss oil pumps - older series			➔	Replacemet Danfoss types		
Type	Code no.	1/2-pipe	➔	Type	Code no.	Comments/accessories
MSLA 032	071B0101	1	➔	BFP 21 R3	071N0157	
MSLA 032	071B0102	2	➔	BFP 21 R3	071N0157 ⁷⁾	
MSLA 032	071B0103	1	➔	BFP 21 R3	071N0157	MSLA = 100 V a.c.
MSLA 032	071B0104	2	➔	BFP 21 R3	071N0157 ⁷⁾	+ coil 110-120 V a.c.: 071N0061
MSLA 032	071B0105	1	➔	BFP 21 R3	071N0157	+ coil 110-120 V a.c.: 071N0061
MSLA 032	071B0108	2	➔	BFP 21 R3	071N0157 ⁷⁾	MSLA = 200 V a.c.
MSLA 032	071B0112	2	➔	BFP 21 R3	071N0157 ⁷⁾	
MSLA 032	071B0113	1	➔	BFP 21 R3	071N0157	
MSLA 032	071B0132	2	➔	BFP 21 R3	071N0157 ⁷⁾	+ coil 24 V a.c.: 071N0062
MSLA 032	071B1101	1	➔	BFP 21 L3	071N0156 ⁶⁾	
MSLA 032	071B1102	2	➔	BFP 21 L3	071N0156 ⁶⁾ 7)	
MSLA 032	071B1103	1	➔	BFP 21 L3	071N0156 ⁶⁾	MSLA = 100 V a.c.
MSLA 032	071B1104	2	➔	BFP 21 L3	071N0156 ⁷⁾	+ coil 110-120 V a.c.: 071N0061
MSLA 032	071B1105	1	➔	BFP 21 L3	071N0156 ⁶⁾	+ coil 110-120 V a.c.: 071N0061
MSLA 032	071B1111	1	➔	BFP 21 L3	071N0156 ⁶⁾	
MSLA 032	071B1112	2	➔	BFP 21 L3	071N0156 ⁶⁾ 7)	
MSLA 032	071B1114	2	➔	BFP 21 L3	071N0156 ⁶⁾ 7)	
MSLA 032	071B1118	2	➔	BFP 21 L3	071N0156 ⁶⁾ 7)	
MSLA 032	071B1120	2	➔	BFP 21 L3	071N0156 ⁶⁾ 7)	
MSLA 032	071B1126	2	➔	BFP 21 L3	071N0156 ⁶⁾ 7)	
MSLA 032	071B1128	2	➔	BFP 21 L3	071N0156 ⁶⁾ 7)	
MSLA 032	071B1132	2	➔	BFP 21 L3	071N0156 ⁶⁾ 7)	+ coil 24 V a.c.: 071N0062
MSLA 032	071B1134	2	➔	BFP 21 L3	071N0156 ⁶⁾ 7)	
MSLA 032	071B1136	2	➔	BFP 21 L3	071N0156 ⁶⁾ 7)	
MSLA 032	071B1138	2	➔	BFP 21 L3	071N0156 ⁶⁾ 7)	

+ cable,
L = 710 mm:
071G0204

6) If the pump is wanted delivered incl. cable, bush and flange, please order 071N0132.

7) This pump is for one-pipe operation. On pumps for two-pipe operation the changeover screw must be fitted.

Oil pumps – Danfoss MSLA/MSLB

Danfoss oil pumps - older series			➔	Replacement Danfoss types		
Type	Code no.	1/2-pipe	➔	Type	Code no.	Comments/accessories
MSLA 050	071B0201	1	➔	BFP 21 R5	071N0173 ²⁾	
MSLA 050	071B0202	2	➔	BFP 21 R5	071N0173 ²⁾	
MSLA 050	071B0203	1	➔	BFP 21 R5	071N0173 ²⁾	MSLA = 100 V a.c. + coil 110-120 V a.c.: 071N0061
MSLA 050	071B0204	2	➔	BFP 21 R5	071N0173 ²⁾	+ coil 110-120 V a.c.: 071N0061
MSLA 050	071B0205	1	➔	BFP 21 R5	071N0173 ²⁾	MSLA = 200 V a.c.
MSLA 050	071B0208	2	➔	BFP 21 R5	071N0173 ²⁾	
MSLA 050	071B1201	1	➔	BFP 21 L5	071N0172 ²⁾	
MSLA 050	071B1202	2	➔	BFP 21 L5	071N0172 ²⁾	
MSLA 050	071B1203	1	➔	BFP 21 L5	071N0172 ²⁾	MSLA = 100 V a.c. + coil 110-120 V a.c.: 071N0061
MSLA 050	071B1204	2	➔	BFP 21 L5	071N0172 ²⁾	
MSLB 032	071B2101	1	➔	BFP 20 R3	071N0169 ²⁾	<p>Please note:</p> <p>If a BFP 20 is used on a gravity feed installation, a solenoid valve (if not existing) must be fitted in the nozzle line to ensure "shut off" on burner stop.</p> <p>If a valve is not fitted, then use a BFP 21 and wire the pump's solenoid valve into the control box.</p>
MSLB 032	071B3101	1	➔	BFP 20 L3	071N0168 ²⁾	
MSLB 032	071B2102	2	➔	BFP 20 R3	071N0169 ²⁾	
MSLB 032	071B2104	2	➔	BFP 20 R3	071N0169 ²⁾	
MSLB 032	071B3102	2	➔	BFP 20 L3	071N0168 ²⁾	
MSLB 050	071B2201	1	➔	BFP 20 R5	071N0129 ²⁾	
MSLB 050	071B3201	1	➔	BFP 20 L5	071N0126 ²⁾	
MSLB 050	071B2202	2	➔	BFP 20 R5	071N0129 ²⁾	
MSLB 050	071B2203	1	➔	BFP 20 R5	071N0129 ²⁾	
MSLB 050	071B3202	2	➔	BFP 20 L5	071N0126 ²⁾	

2) Important: These pumps are delivered for two-pipe operation. If the pumps are mounted on a one-pipe system, the changeover screw must be removed (fig. page 6) and the return port must be stopped with a metal plug.

Oil pumps – Danfoss MSLC/MSLD

Danfoss oil pumps - older series			➔	Replacement Danfoss types		
Type	Code no.	1/2-pipe	➔	Type	Code no.	Comments/accessories
MSLC 032	071B4101	1	➔	BFP 21 R3	071N0157 ¹⁾	
MSLC 032	071B5101	1	➔	BFP 21 L3	071N0156 ^{1) 6)}	+ cable, L = 710 mm: 071G0204
MSLC 032	071B4102	2	➔	BFP 21 R3	071N0157 ^{1) 7)}	
MSLC 032	071B5102	2	➔	BFP 21 L3	071N0156 ^{1) 6) 7)}	
MSLC 032	071B4103	1	➔	BFP 21 R5	071N0173 ^{1) 2)}	
MSLC 032	071B4105	1	➔	BFP 21 R3	071N0157 ¹⁾	
MSLC 050	071B4201	1	➔	BFP 21 R5	071N0173 ^{1) 2)}	+ cable, L = 710 mm: 071G0204
MSLC 050	071B5201	1	➔	BFP 21 L5	071N0172 ^{1) 2)}	
MSLC 050	071B4202	2	➔	BFP 21 R5	071N0173 ^{1) 2)}	
MSLC 050	071B5202	2	➔	BFP 21 L5	071N0172 ^{1) 2)}	
MSLD 032	071B6101	1	➔	BFP 20 R3	071N0169 ²⁾	
MSLD 032	071B6102	2	➔	BFP 20 R3	071N0169 ²⁾	
MSLD 032	071B7101	1	➔	BFP 20 L3	071N0168 ²⁾	
MSLD 032	071B7102	2	➔	BFP 20 L3	071N0168 ²⁾	
MSLD 032	071B6201	1	➔	BFP 20 R5	071N0129 ²⁾	
MSLD 050	071B6202	2	➔	BFP 20 R5	071N0129 ²⁾	
MSLD 050	071B7201	1	➔	BFP 20 L5	071N0126 ²⁾	
MSLD 050	071B7202	2	➔	BFP 20 L5	071N0126 ²⁾	

1) The solenoid coil must be connected in parallel with the burner motor.

2) Important: These pumps are delivered for two-pipe operation. If the pumps are mounted on a one-pipe system, the changeover screw must be removed (fig. page 6) and the return port must be stopped with a metal plug.

6) If the pump is wanted delivered incl. cable, bush and flange, please order 071N0132.

7) This pump is for one-pipe operation. On pumps for two-pipe operation the changeover screw must be fitted.

Oil pumps – Danfoss MS

Danfoss oil pumps - older series			➔	Replacement Danfoss types		
Type	Code no.	1/2-pipe	➔	Type	Code no.	Comments/accessories
MS 10 L3	071G0125	1 + 2	➔	BFP 20 L3	071N0168 ²⁾	
MS 10 R3	071G0123	1 + 2	➔	BFP 20 R3	071N0169 ²⁾	
MS 10 L3	071G0153	1 + 2	➔		No repl.	
MS 10 R3	071G0175	1 + 2	➔	BFP 20 R3	071N0169 ²⁾	
MS 10 R5	071G0176	1 + 2	➔	BFP 20 R5	071N0129 ²⁾	
MS 10 L5	071G0128	1 + 2	➔	BFP 20 L5	071N0126 ²⁾	
MS 10 R5	071G0124	1 + 2	➔	BFP 20 R5	071N0129 ²⁾	
MS 11 L3	071G0117	1 + 2	➔	BFP 21 L3	071N0156 ^{6) 7)}	
MS 11 R3	071G0118	1 + 2	➔	BFP 21 R3	071N0157 ⁷⁾	
MS 11 L3	071G0121	1 + 2	➔	BFP 21 L3	071N0156 ^{6) 7)}	
MS 11 L3	071G0134	1 + 2	➔	BFP 21 L3	071N0156 ^{6) 7)}	
MS 11 L3	071G0137	1 + 2	➔	BFP 21 L3	071N0156 ^{6) 7)}	
MS 11 L3	071G0139	1 + 2	➔	BFP 21 L3	071N0156 ^{6) 7)}	
MS 11 L3	071G0154	1 + 2	➔	BFP 21 L3	071N0156 ^{6) 7)}	+ coupling with single flat in hole (D-shaped)
MS 11 L3	071G0156	1 + 2	➔	BFP 21 L3	071N0156 ^{6) 7)}	+ coil 24 V a.c.: 071N0062
MS 11 L3	071G0158	1 + 2	➔	BFP 21 L3	071N0156 ^{6) 7)}	
MS 11 R3	071G0160	1 + 2	➔	BFP 21 R3	071N0157 ⁷⁾	+ coil 24 V a.c.: 071N0062
MS 11 L3	071G0162	1 + 2	➔	BFP 21 L3	071N0156 ^{6) 7)}	
MS 11 L3	071G0163	1 + 2	➔	BFP 21 L3	071N0156 ^{6) 7)}	+ coil 24 V a.c.: 071N0062
MS 11 L3	071G0165	1	➔	BFP 21 L3	071N0156 ⁶⁾	
MS 11 R3	071G0173	1 + 2	➔	BFP 21 R3	071N0157 ⁷⁾	
MS 11 R5	071G0174	1 + 2	➔	BFP 21 R5	071N0173 ²⁾	
MS 11 R3	071G0177	1 + 2	➔	BFP 21 R3	071N0157 ⁷⁾	
MS 11 L3	071G0178	1 + 2	➔	BFP 21 L3	071N0156 ^{6) 7)}	

2) Important: These pumps are delivered for two-pipe operation. If the pumps are mounted on a one-pipe system, the changeover screw must be removed (fig. page 6) and the return port must be stopped with a metal plug.

6) If the pump is wanted delivered incl. cable, bush and flange, please order 071N0132.

7) This pump is for one-pipe operation. On pumps for two-pipe operation the changeover screw must be fitted.

Oilpumps – Danfoss MS

Danfoss oil pumps - older series			➔	Replacement Danfoss types		
Type	Code no.	1/2-pipe	➔	Type	Code no.	Comments/accessories
MS 11 L3	071G0179	1 + 2	➔	BFP 21 L3	071N0156 ⁶⁾	Any hydraulic cylinder must be connected to the pressure gauge port on the front.
MS 11 L5	071G0127	1 + 2	➔	BFP 21 L5	071N0172 ²⁾	
MS 11 R5	071G0126	1 + 2	➔	BFP 21 R5	071N0173 ²⁾	
MS 12 L3	071G0115	1 + 2	➔		No repl.	
MS 12 R3	071G0113	1 + 2	➔		No repl.	
MS 12 L5	071G0116	1 + 2	➔		No repl.	
MS 12 R5	071G0114	1 + 2	➔		No repl.	
MS 12 L3	071G0161	1 + 2	➔		No repl.	
MS 12E L3	071G0130	1 + 2	➔	BFP 52E L3	071N2201 ²⁾	
MS 12E R3	071G0129	1 + 2	➔	BFP 52E R3	071N2203 ²⁾	
MS 12E L5	071G0120	1 + 2	➔	BFP 52E L5	071N2202 ²⁾	
MS 12E R5	071G0119	1 + 2	➔	BFP 52E R5	071N2204 ²⁾	
MS 12E L3	071G0140	1 + 2	➔	BFP 52E L3	071N2201 ²⁾	
MS 12E L5	071G0181	1 + 2	➔	BFP 52E L5	071N2202 ²⁾	
MS 21 L3	071G0157	1 + 2	➔	BFP 21 L3	071N0156 ⁶⁾	
MS 21 R3	071G0167	1 + 2	➔	BFP 21 R3	071N0157	

2) Important: These pumps are delivered for two-pipe operation. If the pumps are mounted on a one-pipe system, the changeover screw must be removed (fig. page 6) and the return port must be stopped with a metal plug.

6) If the pump is wanted delivered incl. cable, bush and flange, please order 071N0132.

Oil pumps – Danfoss BFP

BFP			➔	BFP-Service pumps		
Type	Code no.	1/2-pipe	➔	Type	Code no.	Comments/accessories
BFP 11 L3	071N0101	2	➔	BFP 11 L3	071N0141 ³⁾	
BFP 21 L3	071N0102	2	➔	BFP 21 L3	071N0156 ^{6) 7)}	
BFP 11 L3	071N0103	2	➔	BFP 21 L3	071N0156 ^{6) 7)}	
BFP 21 L3	071N0104	2	➔	BFP 21 L3	071N0156 ^{6) 7)}	
BFP 11 L5	071N0105	2	➔	BFP 21 L5	071N0172 ²⁾	
BFP 21 L5	071N0107	2	➔	BFP 21 L3	071N0157 ⁷⁾	
BFP 20 L3	071N0108	1	➔	BFP 20 L3	071N0168 ²⁾	
BFP 21 R3	071N0109	2	➔	BFP 21 R3	071N0157 ⁷⁾	Any hydraulic cylinder must be connected to the pressure gauge port on the front.
BFP 21 L3	071N0111	2	➔	BFP 21 L3	071N0156 ^{6) 7)}	
BFP 21 R3	071N0112	2	➔	BFP 21 R3	071N0157 ⁷⁾	
BFP 21 L3	071N0113	2	➔	BFP 21 L3	071N0156 ^{6) 7)}	
BFP 11 L3	071N0114 ⁵⁾	2	➔	BFP 21 L3	071N0156 ^{6) 7)}	+ coupling with single flat in hole (D-shaped)
BFP 31 L3	071N0115	2	➔	BFP 21 L3	071N0156 ^{6) 7)}	
BFP 21 L5	071N0116	2	➔	BFP 21 L5	071N0172 ²⁾	Any hydraulic cylinder must be connected to the pressure gauge port on the front.
BFP 20 R3	071N0118	1	➔	BFP 20 R3	071N0169 ²⁾	
BFP 21 L3	071N0119	2	➔	BFP 21 L3	071N0156 ⁷⁾	
BFP 21 R5	071N0120	1	➔	BFP 21 R5	071N0172 ²⁾	
BFP 21 L3	071N0122	1	➔	BFP 21 L3	071N0156 ⁶⁾	
BFP 21 L3	071N0123	2	➔	BFP 21 L3	071N0156 ⁷⁾	+ coil 110 V: 071N0061
BFP 20 L3	071N0125	2	➔	BFP 20 L3	071N0168 ²⁾	
BFP 20 L5	071N0126	2	➔	BFP 20 L5	071N0126 ²⁾	

2) Important: These pumps are delivered for two-pipe operation. If the pumps are mounted on a one-pipe system, the changeover screw must be removed (fig. page 6) and the return port must be stopped with a metal plug.

3) A screw for 2-pipe operation is fitted under the cover of these pumps.

Without horseshoe washer: Pump set for 2-pipe operation. With horseshoe washer: Pump set for 1-pipe operation.

6) If the pump is wanted delivered incl. cable, bush and flange, please order 071N0132.

7) This pump is for one-pipe operation. On pumps for two-pipe operation the changeover screw must be fitted.

Oil pumps – Danfoss BFP

BFP			➔	BFP-Service pumps		
Type	Code no.	1/2-pipe	➔	Type	Code no.	Comments/accessories
BFP 20 L3	071N0127	1	➔	BFP 20 L3	071N0168 ²⁾	
BFP 20 R3	071N0128	1	➔	BFP 20 L3	071N0169 ²⁾	
BFP 20 R5	071N0129	2	➔	BFP 20 R5	071N0129 ²⁾	
BFP 21 L3	071N0130	2	➔	BFP 21 L3	071N0156 ⁷⁾	
BFP 21 L3	071N0132	1	➔	BFP 21 L3	071N0156	
BFP 31 L3	071N0133	2	➔	BFP 21 L3	071N0156 ⁷⁾	+ coupling with single flat in hole (D-shaped)
BFP 41 L3	071N0135	2	➔	BFP 41 L3	071N0160 ⁷⁾	
BFP 21 R3	071N0136	1	➔	BFP 21 R3	071N0157	
BFP 41 R3	071N0137	2	➔	BFP 21 R3	071N0157 ⁷⁾	
BFP 11 L3	071N0141 ³⁾	1	➔	BFP 11 L3	071N0141 ³⁾	
BFP 11 L3	071N0142 ³⁾	1	➔	BFP 11 L3	071N0141 ³⁾	
BFP 11 R3	071N0143 ³⁾	1	➔	BFP 11 R3	071N0155 ³⁾	
BFP 11 L3	071N0144 ³⁾	2	➔	BFP 11 L3	071N0141 ³⁾	
BFP 11 R3	071N0145 ³⁾	2	➔	BFP 11 R3	071N0155 ³⁾	
BFP 11 L3	071N0146 ³⁾	2	➔	BFP 11 L3	071N0141 ³⁾	Old coil might be usable.
BFP 21 L3	071N0147	2	➔	BFP 21 L3	071N0156 ⁷⁾	
BFP 21 L3	071N0148	2	➔	BFP 21 L3	071N0156 ⁷⁾	
BFP 31 L3	071N0149	2	➔	BFP 21 L3	071N0156 ⁷⁾	
BFP 21 L3	071N0150	2	➔	BFP 21 L3	071N0156 ⁷⁾	
BFP 21 L3	071N0151	2	➔	BFP 21 L3	071N0156 ⁷⁾	
BFP 11 L3	071N0152 ³⁾	2	➔	BFP 11 L3	071N0141 ³⁾	
BFP 11 L3	071N0153 ³⁾	2	➔	BFP 11 L3	071N0141 ³⁾	+ coil 24 V a.c.: 071N0062

2) Important: These pumps are delivered for two-pipe operation. If the pumps are mounted on a one-pipe system, the changeover screw must be removed (fig. page 6) and the return port must be stopped with a metal plug.

3) A screw for 2-pipe operation is fitted under the cover of these pumps.

Without horseshoe washer: Pump set for 2-pipe operation. With horseshoe washer: Pump set for 1-pipe operation.

7) This pump is for one-pipe operation. On pumps for two-pipe operation the changeover screw must be fitted.

Oil pumps – Danfoss BFP

BFP			➔	BFP-Service pumps		
Type	Code no.	1/2-pipe	➔	Type	Code no.	Comments/accessories
BFP 21 R3	071N0154	1	➔	BFP 21 R3	071N0157	
BFP 11 R3	071N0155 ³⁾	1	➔	BFP 11 R3	071N0155 ³⁾	
BFP 21 L3	071N0156	1	➔	BFP 21 L3	071N0156	
BFP 21 R3	071N0157	1	➔	BFP 21 R3	071N0157	
BFP 21 L5	071N0158	1	➔	BFP 21 L5	071N0172 ²⁾	
BFP 21 R5	071N0159	1	➔	BFP 21 R5	071N0173 ²⁾	
BFP 41 L3	071N0160	1	➔	BFP 41 L3	071N0160	
BFP 20 L3	071N0161	1	➔	BFP 20 L3	071N0168 ²⁾	
BFP 20 R3	071N0162	1	➔	BFP 20 R3	071N0169 ²⁾	
BFP 11 R5	071N0163	2	➔	BFP 21 R5	071N0173 ²⁾	
BFP 21 L3	071N0164	2	➔	BFP 21 L3	071N0156 ⁷⁾	
BFP 11 R5	071N0165 ³⁾	2	➔	BFP 21 R5	071N0173 ²⁾	
BFP 10 R5	071N0166	2	➔	BFP 20 R5	071N0129 ²⁾	
BFP 21 R3	071N0167	2	➔	BFP 21 R3	071N0157 ⁷⁾	
BFP 20 L3	071N0168	2	➔	BFP 20 L3	071N0168 ²⁾	
BFP 20 R3	071N0169	2	➔	BFP 20 R3	071N0169 ²⁾	
BFP 21 L3	071N0170	2	➔	BFP 21 L3	071N0160 ⁷⁾	
BFP 21 R3	071N0171	2	➔	BFP 21 R3	071N0157 ⁷⁾	
BFP 21 L5	071N0172	2	➔	BFP 21 L5	071N0172 ²⁾	
BFP 21 R5	071N0173	2	➔	BFP 21 R5	071N0173 ²⁾	
BFP 41 L3	071N0174	2	➔	BFP 41 L3	071N0160 ⁷⁾	
BFP 21 L3	071N0175	1	➔	BFP 21 L3	071N0156	
BFP 21 L3	071N0176	1	➔	BFP 21 L3	071N0156	+ coil: 071N0061

2) Important: These pumps are delivered for two-pipe operation. If the pumps are mounted on a one-pipe system, the changeover screw must be removed (fig. page 6) and the return port must be stopped with a metal plug.

3) A screw for 2-pipe operation is fitted under the cover of these pumps.

Without horseshoe washer: Pump set for 2-pipe operation. With horseshoe washer: Pump set for 1-pipe operation.

7) This pump is for one-pipe operation. On pumps for two-pipe operation the changeover screw must be fitted

Oil pumps – Danfoss BFP

BFP			➔	BFP-Service pumps		
Type	Code no.	1/2-pipe	➔	Type	Code no.	Comments/accessories
BFP 10 R3	071N0177	2	➔	BFP 20 R3	071N0169 ²⁾	
BFP 11 L5	071N0178	2	➔	BFP 21 L5	071N0172 ²⁾	
BFP 21 L3	071N0179	2	➔	BFP 21 L3	071N0156	
BFP 20 R5	071N0180	2	➔	BFP 20 R5	071N0129 ²⁾	
BFP 11 R3	071N0181	2	➔	BFP 11 R3	071N0155 ³⁾	
BFP 21 L3	071N0182	2	➔	BFP 21 L3	071N0156 ⁷⁾	
BFP 11 R3	071N0183	2	➔	BFP 11 R3	071N0155 ^{3) 7)}	
BFP 11 L3	071N0184 ²⁾	2	➔	BFP 11 L3	071N0141 ³⁾	
BFP 21 L3	071N0185	2	➔	BFP 21 L3	071N0156 ⁷⁾	
BFP 41 L3	071N0188	2	➔	BFP 41 L3	071N0160 ⁷⁾	
BFP 21 L3	071N0189	2	➔	BFP 21 L3	071N0156 ⁷⁾	+ coil: 071N0062
BFP 31 L3	071N0190	2	➔	BFP 11 L3	071N0141 ³⁾	
BFP 31 R3	071N0191	2	➔	BFP 11 R3	071N0155 ³⁾	
BFP 31 L3	071N0192	1	➔	BFP 11 L3	071N0141 ³⁾	
BFP 21 L3	071N0193	1	➔	BFP 21 L3	071N0156 ⁶⁾	
BFP 21 L5	071N0194	1	➔	BFP 21 L5	071N0172 ²⁾	
BFP 21 R5	071N0195	1	➔	BFP 21 R5	071N0173 ²⁾	
BFP 41 R3	071N0196	1	➔	BFP 21 R3	071N0157	
BFP 21 L3	071N0197	2	➔	BFP 21 L3	071N0156 ⁷⁾	
BFP 21 R3	071N0198	1	➔	BFP 21 R3	071N0157	
BFP 21 L5	071N0202	2	➔	BFP 21 L5	071N0172 ²⁾	
BFP 21 L3	071N0204	2	➔		No repl.	

2) Important: These pumps are delivered for two-pipe operation. If the pumps are mounted on a one-pipe system, the changeover screw must be removed (fig. page 6) and the return port must be stopped with a metal plug.

3) A screw for 2-pipe operation is fitted under the cover of these pumps.

Without horseshoe washer: Pump set for 2-pipe operation. With horseshoe washer: Pump set for 1-pipe operation.

7) This pump is for one-pipe operation. On pumps for two-pipe operation the changeover screw must be fitted.

Oil pumps – Danfoss BFP

BFP				BFP-Service pumps		
Type	Code no.	1/2-pipe	➔	Type	Code no.	Comments/accessories
BFP 21 R5	071N0207	2	➔	BFP 21 R5	071N0173 ²⁾	
BFP 21 R3	071N0208	2	➔	BFP 21 R3	071N0157 ⁷⁾	
BFP 11 L3	071N0210 ³⁾	1	➔	BFP 11 L3	071N0141 ³⁾	
BFP 20 L3	071N0212	2	➔	BFP 20 L3	071N0168 ²⁾	+ coupling with single flat in hole (D-shaped)
BFP 11 L3	071N0213 ³⁾	1	➔	BFP 11 L3	071N0141 ³⁾	
BFP 21 R3	071N0214	1	➔	BFP 21 R3	071N0157	
BFP 21 R3	071N0215	2	➔	BFP 21 R3	071N0157 ⁷⁾	071N0215 has G 1/8 in S+R
BFP 21 L3	071N0217	2	➔	BFP 21 L3	071N0156 ⁷⁾	
BFP21L3-LE	071N2103	2	➔	BFP 21 L3 LE	071N2113	
BFP21L3-LE	071N2104	2	➔	BFP 21 L3 LE	071N2113	
BFP21R3LE	071N2107	2	➔	BFP 21 R3 LE	071N2107	
BFP31L3-LE	071N2109	2	➔	BFP 21 L3 LE	071N2113	
BFP21L3-LE	071N2113	2	➔	BFP 21 L3 LE	071N2113	
BFP21L3-LE	071N2114	2	➔	BFP 21 L3 LE	071N2113	
BFP 52E L3	071N2201	2	➔	BFP 52E L3	071N2201	
BFP 52E L5	071N2202	2	➔	BFP 52E L5	071N2202	
BFP 52E R3	071N2203	2	➔	BFP 52E R3	071N2203	
BFP 52E R5	071N2204	2	➔	BFP 52E R5	071N2204	
BFP 52E L5	071N2205	2	➔	BFP 52E L5	071N2202	
BFP 52E R5	071N2206	2	➔	BFP 52E R5	071N2204	
BFP 52E L3	071N2211	2	➔	BFP 52E L3	071N2201	
BFP 52E L5	071N2212	2	➔	BFP 52E L5	071N2202	+ coupling with single flat in hole (D-shaped)
BFP 52E L3	071N2213	2	➔	BFP 52E L3	071N2201	

2) Important: These pumps are delivered for two-pipe operation. If the pumps are mounted on a one-pipe system, the changeover screw must be removed (fig. page 6) and the return port must be stopped with a metal plug.

3) A screw for 2-pipe operation is fitted under the cover of these pumps.

Without horseshoe washer: Pump set for 2-pipe operation. With horseshoe washer: Pump set for 1-pipe operation.

7) This pump is for one-pipe operation. On pumps for two-pipe operation the changeover screw must be fitted.

Oil pumps – Suntec

Suntec			➔	Danfoss oil pumps		
Type	Code no.	1/2-pipe	➔	Type	Code no.	Comments/accessories
AN47A	13261P	2	➔	BFP 20 R3	071N0169 ²⁾	
AN47D	13391P	2	➔	BFP 20 L3	071N0168 ²⁾	
AN47C	13421P	2	➔	BFP 20 L3	071N0168 ²⁾	
AN47B	13951P	2	➔	BFP 20 R3	071N0169 ²⁾	
AN47A	72163P	2	➔	BFP 20 R3	071N0169 ²⁾	
AN47B	72173P	2	➔	BFP 20 R3	071N0169 ²⁾	+ flange and bush Ø54: 071N0047
AN47C	72183P	2	➔	BFP 20 L3	071N0168 ²⁾	
AN47D	72193P	2	➔	BFP 20 L3	071N0168 ²⁾	
AN47A	72263P	2	➔	BFP 20 R3	071N0169 ²⁾	
AN47B	72273P	2	➔	BFP 20 R3	071N0169 ²⁾	+ bush Ø54: 071B0011
AN47C	72283P	2	➔	BFP 20 L3	071N0168 ²⁾	
AN47D	72293P	2	➔	BFP 20 L3	071N0168 ²⁾	
AN47C	72473M	1	➔	BFP 20 L3	071N0168 ²⁾	+ 071N0047, possible changeover to 1-pipe operation
AN47A	72832M	1	➔	BFP 20 R3	071N0169 ²⁾	
AN47A	73263P	2	➔	BFP 20 R3	071N0169 ²⁾	
AN47B	73273P	2	➔	BFP 20 R3	071N0169 ²⁾	
AN47C	73283P	2	➔	BFP 20 L3	071N0168 ²⁾	
AN47A	73443P	2	➔	BFP 20 R3	071N0169 ²⁾	
AN57B	13301P	2	➔	BFP 20 R5	071N0129 ²⁾	
AN57A	72433P	2	➔	BFP 20 R5	071N0129 ²⁾	+ flange and bush Ø54: 071N0047
AN57C	72823P	2	➔	BFP 20 L5	071N0126 ²⁾	
AN67B	13351P	2	➔	BFP 20 R5	071N0129 ²⁾	
AN67C	13361P	2	➔	BFP 20 L5	071N0126 ²⁾	Suntec: 80 l/h, BFP: 40 l/h at 12 bar
AN67D	13571P	2	➔	BFP 20 L5	071N0126 ²⁾	
AN67C	72333P	2	➔	RSA 40	070L3249 ²⁾	+ flange: 070-0211

2) Important: These pumps are delivered for two-pipe operation. If the pumps are mounted on a one-pipe system, the changeover screw must be removed (fig. page 6) and the return port must be stopped with a metal plug.

Oil pumps – Suntec

Suntec			➔	Danfoss oil pumps		
Type	Code no.	1/2-pipe	➔	Type	Code no.	Comments/accessories
AN67A	72383P	2	➔	BFP 20 R5	071N0129 ²⁾	+ flange: 071N0047 Suntec: 80 l/h, BFP: 40 l/h at 12 bar
AN67C	72423P	2	➔	RSA 40	070L3249 ²⁾	+ flange: 070-0211
AN67B	72513P	2	➔	RSA 40	070-3249 ²⁾	
AN67D	72523P	2	➔	BFP 20 L5	071N0126 ²⁾	+ flange: 071N0047 Suntec: 80 l/h, BFP: 40 l/h at 12 bar
AN67B	73353P	2	➔	BFP 20 R5	071N0129 ²⁾	
AN67A	73453P	2	➔	BFP 20 R5	071N0129 ²⁾	+ 24 V a.c. coil: 071N0062
AL35B	95202P0200	2	➔	BFP 21 R3	071N0157 ⁷⁾	
AL35B	95202P0500	2	➔	BFP 21 R3	071N0157 ⁷⁾	
AL35C	95212P0500	2	➔	BFP 21 L3	071N0156 ^{6) 7)}	
AL35C	95242M0500	1	➔	BFP 21 L3	071N0156 ⁶⁾	
AL35A	95262P0500	2	➔	BFP 21 R3	071N0157 ⁷⁾	
AL35C	95282P0500	2	➔	BFP 21 L3	071N0156 ^{6) 7)}	
AL35D	95292P0200	2	➔	BFP 21 L3	071N0156 ^{6) 7)}	+ 24 V a.c. coil: 071N0062
AL35C	95402P0500	2	➔	BFP 21 L3	071N0156 ^{6) 7)}	Suntec: G 1/8 in S+R
AL35C	95652M0500	1	➔	BFP 21 L3	071N0156 ⁶⁾	
AL35A	95702P0500	2	➔	BFP 21 R3	071N0157 ⁷⁾	
AL35C	95782P0500	2	➔	BFP 21 L3	071N0156 ^{6) 7)}	
AL35B	95802P0500	2	➔	BFP 21 R3	071N0157 ⁷⁾	
AL35C	95402P0500R	2	➔	BFP 21 L3	071N0156 ^{6) 7)}	
AL55B	95312P0500	2	➔	BFP 21 R5	071N0173 ²⁾	
AS47A	15361P0500	2	➔	BFP 21 R3	071N0157 ⁷⁾	
AS47B	15371P0500	2	➔	BFP 21 R3	071N0157 ⁷⁾	
AS47C	15381P0500	2	➔	BFP 21 L3	071N0156 ^{6) 7)}	
AS47D	15391P0500	2	➔	BFP 21 L3	071N0156 ^{6) 7)}	

2) Important: These pumps are delivered for two-pipe operation. If the pumps are mounted on a one-pipe system, the changeover screw must be removed (fig. page 6) and the return port must be stopped with a metal plug.

6) If the pump is wanted delivered incl. cable, bush and flange, please order 071N0132.

7) This pump is for one-pipe operation. On pumps for two-pipe operation the changeover screw must be fitted.

Oil pumps – Suntec

Suntec			➔	Danfoss oil pumps		
Type	Code no.	1/2-pipe	➔	Type	Code no.	Comments/accessories
AS47D	15501P0500	2	➔	BFP 21 L3	071N0156 ^(6) 7)	
AS47B	15511P0500	2	➔	BFP 21 R3	071N0157 ⁷⁾	
AS47C	15541P0500	2	➔	BFP 21 L3	071N0156 ^(6) 7)	
AS47D	15571P0500	2	➔	BFP 21 L3	071N0156 ^(6) 7)	+ coupling with single flat in hole (D-shaped)
AS47D	15621P0500	2	➔	BFP 21 L3	071N0156 ^(6) 7)	
AS47D	15681P0500	2	➔	BFP 21 L3	071N0156 ^(6) 7)	
AS47C	15691P0500	2	➔	BFP 21 L3	071N0156 ^(6) 7)	
AS47D	15721P0500	2	➔	BFP 21 L3	071N0156 ^(6) 7)	
AS47D	15801P0500	2	➔	BFP 21 L3	071N0156 ^(6) 7)	
AS47A	74323P0500	2	➔	BFP 21 R3	071N0157 ⁷⁾	
AS47C	74343P0500	2	➔	BFP 21 L3	071N0156 ^(6) 7)	+ flange and bush Ø54: 071N0047
AS47D	74353P0500	2	➔	BFP 21 L3	071N0156 ^(6) 7)	
AS47A	74363P0500	2	➔	BFP 21 R3	071N0157 ⁷⁾	
AS47C	74383P0500	2	➔	BFP 21 L3	071N0156 ^(6) 7)	+ bush Ø54: 071B0011
AS47D	74393P0500	2	➔	BFP 21 L3	071N0156 ^(6) 7)	
AS47C	74443P0500	2	➔	BFP 21 L3	071N0156 ^(6) 7)	
AS47B	74453P0500	2	➔	BFP 21 R3	071N0157 ⁷⁾	+ flange and bush Ø54: 071N0047
AS47C	74513M0500	1	➔	BFP 21 L3	071N0156 ⁽⁶⁾	
AS47C	74613P0500	2	➔	BFP 21 L3	071N0156 ^(6) 7)	
AS47C	75543P0500	2	➔	BFP 21 L3	071N0156 ^(6) 7)	
AS47D	75623P0500	2	➔	BFP 21 L3	071N0156 ^(6) 7)	
AS47A	75643P0500	2	➔	BFP 21 R3	071N0157 ⁷⁾	
AS57C	15441P0500	2	➔	BFP 21 L5	071N0172 ^(2) 7)	
AS57C	74413P0500	2	➔	BFP 21 L5	071N0172 ⁽²⁾	
AS57B	74423P0500	2	➔	BFP 21 R5	071N0173 ⁽²⁾	+ flange and bush Ø54: 071N0047

2) Important: These pumps are delivered for two-pipe operation. If the pumps are mounted on a one-pipe system, the changeover screw must be removed (fig. page 6) and the return port must be stopped with a metal plug.

6) If the pump is wanted delivered incl. cable, bush and flange, please order 071N0132.

7) This pump is for one-pipe operation. On pumps for two-pipe operation the changeover screw must be fitted.

Oil pumps – Suntec

Suntec			➔	Danfoss oil pumps		
Type	Code no.	1/2-pipe	➔	Type	Code no.	Comments/accessories
AS57C	75443P0500	2	➔	BFP 21 L5	071N0172 ²⁾	
AE45C	13601P	2	➔	BFP 20 L5	071N0126 ²⁾	
AE45C	13701M	1	➔	BFP 20 L5	071N0126 ²⁾	Possible changeover to 1-pipe operation Suntec: 1/8 NPTF in nozzle outlet
AE47B	13661P	2	➔	BFP 20 R5	071N0129 ²⁾	
AE47D	13781M	1	➔	BFP 20 L5	071N0126 ²⁾	
AE47A	13841M	1	➔	BFP 20 R5	071N0129 ²⁾	Possible changeover to 1-pipe operation
AE47D	13851P	2	➔	BFP 20 L5	071N0126 ²⁾	
AE47C	13861P	2	➔	BFP 20 L5	071N0126 ²⁾	
AE47C	13871P	2	➔	BFP 20 L5	071N0126 ²⁾	
AE47B	72673P	2	➔	BFP 20 R5	071N0129 ²⁾	+ bush Ø54: 071B0011
AE47C	72743M	1	➔	BFP 20 L5	071N0126 ²⁾	+ flange and bush Ø54: 071N0047, Possible changeover to 1-pipe operation
AE47C	73683P	2	➔	BFP 20 L5	071N0126 ²⁾	
AE57B	13641M	1	➔	BFP 20 R5	071N0129 ²⁾	Possible changeover to 1-pipe operation
AE57C	73733P	2	➔	BFP 20 L5	071N0126 ²⁾	
AE67D	72783P	2	➔	BFP 20 L5	071N0126 ²⁾	+ flange: 071N0047 Suntec: 80 l/h, BFP: 40 l/h at 12 bar
AE67C	73613P	2	➔	BFP 20 L5	071N0126 ²⁾	Suntec: 80 l/h, BFP: 40 l/h at 12 bar
AE77C	72702P	2	➔	RSA 60	070L3347 ²⁾	+ flange: 070-0211 Possible changeover to 1-pipe operation
AE77C	73802P	2	➔	BFP 20 L5	071N0126 ²⁾	Suntec: 80 l/h, BFP: 40 l/h at 12 bar
AE97C	73902P	2	➔	BFP 20 L5	071N0126 ²⁾	Suntec: 130 l/h, BFP: 40 l/h at 12 bar
AP47A	75553P0500	2	➔		No repl.	
AP47C	75563P0500	2	➔	BFP 52E L5	071N2202 ^{2) 4)}	

2) Important: These pumps are delivered for two-pipe operation. If the pumps are mounted on a one-pipe system, the changeover screw must be removed (fig. page 6) and the return port must be stopped with a metal plug.

4) The pump NC valve must be connected in parallel to the NC valve in the nozzle line.

Oil pumps – Suntec

Suntec			➔	Danfoss oil pumps		
Type	Code no.	1/2-pipe	➔	Type	Code no.	Comments/accessories
AP47B	75613P0500	2	➔	BFP 52E R5	071N2204 ⁴⁾	
AP47C	74603P0500	2	➔	BFP 52E L5	071N2202 ⁴⁾	+ flange and bush Ø54: 071N0047
AP57C	74433P0500	2	➔	BFP 52E L5	071N2202 ⁴⁾	Suntec: 35 l/h, BFP: 26 l/h at 22 bar + 071N0047
AP57C	75453P0500	2	➔	BFP 52E L5	071N2202 ⁴⁾	
AP57A	75493P0500	2	➔	BFP 52E R5	071N2204 ⁴⁾	Suntec: 35 l/h, BFP: 26 l/h at 22 bar
AP67C	74583P0500	2	➔	BFP 52E L5	071N2202 ⁴⁾	Suntec: 58 l/h, BFP: 26 l/h at 22 bar + 071N0047
AP67C	75593P0500	2	➔	BFP 52E L5	071N2202 ⁴⁾	Suntec: 58 l/h, BFP: 26 l/h at 22 bar
AP245C	95541P0500	2	➔	BFP 52E L5	071N2202 ⁴⁾	
AP245C	95601P0500	2	➔	BFP 52E L5	071N2202 ⁴⁾	
AP265C	95111P0500	2	➔	BFP 52E L5	071N2202 ⁴⁾	Suntec: 68 l/h, BFP: 26 l/h at 22 bar
AP345C	95101P0500	2	➔		No repl.	Suntec: No pressure on the measuring port on the front in stage 1.
AT245C	95412P0500	2	➔	BFP 52E L5	071N2202	
AT245D	95442P0500	2	➔		No repl.	
AT245A	95472P0500	2	➔		No repl.	Suntec: Nozzle output on right
AT245D	95482M0500	1	➔		No repl.	
AT255C	95492P0500	2	➔	BFP 52E L5	071N2202	Suntec: 47 l/h, BFP: 26 l/h at 22 bar
AT255A	95522P0500	2	➔		No repl.	Suntec: Nozzle output on right
AT265C	95562P0500	2	➔	BFP 52E L5	071N2202	Suntec: 68 l/h, BFP: 26 l/h at 22 bar
AT3....			➔		No repl.	Special pump

4) The pump NC valve must be connected in parallel to the NC valve in the nozzle line.

Oil pumps – Eckerle

Eckerle		➡	Danfoss oil pumps		
Old designation	New designation	➡	Type	Code no.	Comments/accessories
UNI 1.1 L5 L64W	UNI-E 2.1 L1 L64	➡	BFP 20 L3	071N0168 ²⁾	Eckerle: G 1/8 in S+R
UNI 1.2 L1 L64-50	UNI 2.12 L1 L64	➡	BFP 21 L3	071N0156 ⁶⁾	
UNI 1.2 L5 L14	UNI 2.12 L1 L14	➡	BFP 21 L3	071N0156 ⁶⁾	
UNI 1.2 L5 L64-M1	UNI-E 2.1 L1 L64-21	➡	BFP 21 L3	071N0156 ⁶⁾	Eckerle: G 1/8 in S+R
UNI 1.2 L5 L64-50	UNI 2.12 L1 L64	➡	BFP 21 L3	071N0156 ⁶⁾	
UNI 1.2 L5 M14-50	UNI 2.12 L1 M14	➡	BFP 21 L3	071N0156 ⁶⁾	
UNI 1.2 L5 M64-50-W	UNI 2.12 L1 M64-65	➡	BFP 21 L3	071N0156 ⁶⁾	Eckerle: G 1/8 in S+R
UNI 1.2 L62 M14-01-W	UNI 2.12 L6 M14-65	➡	BFP 21 L5	071N0172 ²⁾	Eckerle: max. 75 l/h, BFP: max 40 l/h at 12 bar
UNI 1.2 L62 L14W		➡	BFP 21 L5	071N0172 ²⁾	
UNI 1.42 L5 A64-W	UNI 2.42 L5 L64-65	➡	BFP 52E L5	071N2202 ²⁾	Eckerle: G 1/8 in S+R
UNI 1.42 L5 L64W		➡	BFP 52E L3	071N2201 ²⁾	
UNI 1.42 L6 L64W		➡	BFP 52E L5	071N2202 ²⁾	
UNI 1.72 L62 L14-W	UNI 2.17 L6 M14-65	➡		No repl.	
UNI 2.1 L1 L40	UNI-E 2.1 L1 L10 (-22,-30)	➡	BFP 20 L3	071N0168 ²⁾	+ coupling with single flat in hole (D-shaped)
UNI 2.1 L1 L44	UNI-E 2.1 L1 L14	➡	BFP 20 L3	071N0168 ²⁾	
UNI 2.1 L1 L44H	UNI-E 2.1 L14	➡	BFP 20 L3	071N0168 ²⁾	
UNI 2.1 R1 L40	UNI-E 2.1 R1 L10	➡	BFP 20 R3	071N0169 ²⁾	+ coupling with single flat in hole (D-shaped)
UNI 2.1 R1 L44-21	UNI-E 2.1 R1 L14	➡	BFP 20 R3	071N0169 ²⁾	
UNI 2.1 L5 L40-21	UNI-E 2.1 L5 L10	➡	BFP 20 L5	071N0126 ²⁾	+ coupling with single flat in hole (D-shaped)
UNI 2.1 L5 L42	UNI-E 2.1 L5 L12	➡	BFP 20 L5	071N0126 ²⁾	+ coupling with single flat in hole (D-shaped) + 071B0011
UNI 2.1 L5 L44	UNI-E 2.1 L5 L14 (-13)	➡	BFP 20 L5	071N0126 ²⁾	
UNI 2.1 L5 L50	UNI-E 2.1 L5 L10	➡	BFP 20 L5	071N0126 ²⁾	Eckerle: 10-25 bar, BFP max. 20 bar + coupling with single flat in hole (D-shaped)
UNI 2.1 L5 R44	UNI-E 2.1 L5 R14 (-13)	➡	BFP 20 L5	071N0126 ²⁾	
UNI 2.1 L5 R94	UNI-E 2.1 L5 R74	➡	BFP 20 L5	071N0126 ²⁾	Eckerle: G 1/8 in S+R

2) Important: These pumps are delivered for two-pipe operation. If the pumps are mounted on a one-pipe system, the changeover screw must be removed (fig. page 6) and the return port must be stopped with a metal plug.

6) If the pump is wanted delivered incl. cable, bush and flange, please order 071N0132.

Oil pumps – Eckerle

Eckerle		➔	Danfoss oil pumps		
Old designation	New designation	➔	Type	Bestellnummer	Comments/accessories
UNI 2.1 R5 L42-UI-21	UNI-E 2.1 R5 L12-80	➔	BFP 20 R5	071N0129 ²⁾	+ coupling with single flat in hole (D-shaped)
UNI 2.1 R5 L43-UI-21	UNI-E 2.1 R5 L13-80	➔	BFP 20 R5	071N0129 ²⁾	+ flange: 071N0047
UNI 2.1 R5 L43		➔	BFP 20 R5	071N0129 ²⁾	
UNI 2.1 R5 L44	UNI-E 2.1 R5 L14	➔	BFP 20 R5	071N0129 ²⁾	
UNI 2.1 R5 L54	UNI-E 2.1 R5 L24	➔	BFP 20 R5	071N0129 ²⁾	Eckerle: max 25 bar
UNI 2.1 R5 R42		➔	BFP 20 R5	071N0129 ²⁾	
UNI 2.1 R5 R44	UNI-E 2.1 R5 R14	➔	BFP 20 R5	071N0129 ²⁾	
UNI 2.1 R5 R45-21	UNI-E 2.1 R5 R15	➔	BFP 20 R5	071N0129 ²⁾	+ bush : 071B0011
	UNI-E 2.1 R5 R60	➔	BFP 20 R5	071N0129 ²⁾	G ¹ / ₈ in S+R + coupling with single flat in hole (D-shaped)
UNI 2.1 R5 R80	UNI-E 2.1 R5 R40	➔	BFP 20 R5	071N0129 ²⁾	+ coupling with single flat in hole (D-shaped)
UNI 2.1 L6 L54	UNI-E 2.1 L6 L24	➔		No repl.	Eckerle: Ø32, RSA 40: Ø54 neck diameter
UNI 2.1 L6 L54-06	UNI-E 2.1 L6 L24	➔		No repl.	
UNI 2.1 R6 L25	UNI-E 2.1 R6 L25	➔	RSA 40	070-3249	
UNI 2.1 R6 R54	UNI-E 2.1 R6 L24	➔		No repl.	Eckerle: Ø32, RSA: Ø54 neck diameter
UNI 2.1 L7 L55	UNI-E 2.1 L7 L15	➔	RSA 60	070L3347	
UNI 2.1 L7 L55-05	UNI-E 2.1 L7 L25	➔	RSA 60	070L3347	
UNI 2.1 R7 L55	UNI-E 2.1 R7 L15	➔	RSA 60	070L3352	Shaft: Eckerle: Ø8, RSA: Ø10
UNI 2.1 G22 L1 L10/L40	UNI-E 2.1 G22	➔	BFP 20 L3	071N0168 ²⁾	+ coupling with single flat in hole (D-shaped)
	UNI-E 2.1 L1 L64 (-21)	➔	BFP 20 L3	071N0168 ²⁾	
	UNI-E 2.1 L5 R74	➔	BFP 20 L5	071N0172 ²⁾	G ¹ / ₈ in S+R
UNI 2.1 G41-21 L1 L10	UNI-E 2.1 G41	➔	BFP 20 L3	071N0168 ²⁾	
	UNI-E 2.1 G41-13	➔	BFP 20 L3	071N0168 ²⁾	+ coupling with single flat in hole (D-shaped)
	UNI-E 2.2 L1 L10	➔	BFP 21 L3	071N0156 ⁶⁾	

2) Important: These pumps are delivered for two-pipe operation. If the pumps are mounted on a one-pipe system, the changeover screw must be removed (fig. page 6) and the return port must be stopped with a metal plug.

6) If the pump is wanted delivered incl. cable, bush and flange, please order 071N0132.

Oil pumps – Eckerle

Eckerle		➡	Danfoss oil pumps		
Old designation	New designation	➡	Type	Code no.	Comments/accessories
UNI 2.2 L1 L14	UNI-E 2.2 L1 L14	➡	BFP 21 L3	071N0156 ⁶⁾	
UNI 2.2 L1 L16W	UNI-E 2.2 L1 L16-10	➡	BFP 21 L3	071N0156 ⁶⁾	+ flange: 071N0047
UNI 2.2 L1 L44	UNI-E 2.2 L1 L14	➡	BFP 21 L3	071N0156 ⁶⁾	
UNI 2.2 L1 R14	UNI-E 2.2 L1 R14-12	➡	BFP 21 L3	071N0156 ⁶⁾	
UNI 2.2 R1 L40	UNI-E 2.2 R1 L10	➡	BFP 21 R3	071N0157	+ coupling with single flat in hole (D-shaped)
UNI 2.2 R1 M14	UNI-E 2.2 R1 M14	➡	BFP 21 R3	071N0157	
UNI 2.2 R1 R24	UNI-E 2.2 R1 R24	➡	BFP 21 R3	071N0157	Eckerle: max 25 bar
	UNI-E 2.2 R1 S14	➡	BFP 21 R3	071N0157	
UNI 2.2 L5 L14	UNI-E 2.2 L5 L14-92	➡	BFP 21 L5	071N0172 ²⁾	Eckerle: G 1/8 in S+R Eckerle: 10-25 bar, BFP: max. 20 bar
UNI 2.2 L5 L15-21-05	UNI-E 2.2 L5 L15	➡	BFP 21 L5	071N0172 ²⁾	+ bush: 071B0011
UNI 2.2 L5 L40-X	UNI-E 2.2 L5 L10-50	➡	BFP 21 L5	071N0172 ²⁾	+ coupling with single flat in hole (D-shaped)
UNI 2.2 L5 L42	UNI-E 2.2 L5 L12	➡	BFP 21 L5	071N0172 ²⁾	+ bush: 071B0011 + coupling with single flat in hole (D-shaped)
UNI 2.2 L5 L60		➡	BFP 21 L5	071N0172 ²⁾	+ coupling with single flat in hole (D-shaped)
	UNI-E 2.2 L5 L60	➡	BFP 21 L5	071N0172 ²⁾	Eckerle: G 1/8 in S+R + coupling with single flat in hole (D-shaped)
UNI 2.2 L5 L62		➡	BFP 21 L5	071N0172 ²⁾	
UNI 2.2 L5 M14-C1	UNI.E 2.2 L5 M14-12	➡	BFP 21 L5	071N0172 ²⁾	
UNI 2.2 L5 S20	UNI-E 2.2 L5 S20	➡	BFP 21 L5	071N0172 ²⁾	Eckerle: 10-25 bar, BFP: max. 20 bar + coupling with single flat in hole (D-shaped)
UNI 2.2 L5 S20-21-BUD	UNI-E 2.2 L5 S20 BUD	➡	BFP 21 L5	071N0172 ²⁾	Eckerle: max 25 bar, BFP: max. 20 bar + coupling with single flat in hole (D-shaped)
UNI 2.2 L5 S74	UNI-E 2.2 L5 L14	➡	BFP 21 L5	071N0172 ²⁾	Eckerle: 10-25 bar, BFP: max. 20 bar + coupling with single flat in hole (D-shaped)

2) Important: These pumps are delivered for two-pipe operation. If the pumps are mounted on a one-pipe system, the changeover screw must be removed (fig. page 6) and the return port must be stopped with a metal plug.

6) If the pump is wanted delivered incl. cable, bush and flange, please order 071N0132.

Oil pumps – Eckerle

Eckerle		➔	Danfoss oil pumps		
Old designation	New designation	➔	Type	Code no.	Comments/accessories
	UNI-E 2.2 L5 S74	➔	BFP 21 L5	071N0172 ²⁾	G ¹ / ₈ in S+R. Eckerle: max 25 bar
UNI 2.2 R5 L14	UNI-E 2.2 R5 L14	➔	BFP 21 R5	071N0173 ²⁾	
	UNI-E 2.2 R5 M14	➔	BFP 21 R5	071N0173 ²⁾	
UNI 2.2 R5 M45	UNI-E 2.2 R5 M15	➔	BFP 21 R5	071N0173 ²⁾	+ bush: 071B0011
UNI 2.2 R5 R14	UNI-E 2.2 R5 R14	➔	BFP 21 R5	071N0173 ²⁾	
UNI 2.2 R5 R60-21	UNI-E 2.2 R5 R60	➔	BFP 21 R5	071N0173 ²⁾	Eckerle: G 1/8 in S+R
UNI 2.2 R5 R80B	UNI-E 2.2 R5 R60	➔	BFP 21 R5	071N0173 ²⁾	+ coupling with single flat in hole (D-shaped)
	UNI-E 2.2 R5 S14	➔	BFP 21 R5	071N0173 ²⁾	
UNI 2.2 R5 S60	UNI-E 2.2 R5 S60	➔	BFP 21 R5	071N0173 ²⁾	
	UNI-E 2.2 L6 L14	➔	BFP 21 L5	071N0172 ²⁾	Eckerle: max 75 l/h, BFP: 40 l/h at 12 bar
UNI 2.2 L6 L16W	UNI-E 2.2 L6 L16-10	➔	BFP 21 L5	071N0172 ²⁾	Eckerle: max 75 l/h, BFP: max 40 l/h at 12 bar + 071N0047
UNI 2.2 L6 L24	UNI-E 2.2 L6 L24	➔	BFP 21 L5	071N0172 ²⁾	
	UNI-E 2.2 L6 LR14-81	➔	BFP 21 L5	071N0172 ²⁾	
UNI 2.2 R6 M24	UNI-E 2.2 R6 M24	➔	BFP 21 R5	071N0173 ²⁾	Eckerle: 75 l/h, BFP: max 40 l/h at 12 bar
UNI 2.2 R6 S24-ET	UNI-E 2.2 R6 S24 (-40)	➔	BFP 21 R5	071N0173 ²⁾	
UNI 2.2 R6 S24 ET(R1)	UNI-E 2.2 R6 S24-40	➔	BFP 21 R5	071N0173 ²⁾	
UNI 2.2 L7 L26		➔	BFP 21 L5	071N0172 ²⁾	Eckerle: 120 l/h, BFP: max 40 l/h at 12 bar + 071N0047
UNI 2.2 L7 L24		➔	BFP 21 L5	071N0172 ²⁾	
	UNI-E 2.2 L7 L28	➔	BFP 21 L5	071N0172 ²⁾	
	UNI-E 2.2 L7 LR14-61	➔	BFP 21 L5	071N0172 ²⁾	Eckerle: 120 l/h, BFP: max 40 l/h at 12 bar
UNI 2.2 R7 L24-05	UNI-E 2.2 R7 L24	➔	BFP 21 R5	071N0173 ²⁾	
UNI 2.2 R7 R24-R1(-ET)	UNI-E 2.2 R7 R24-40	➔	BFP 21 R5	071N0173 ²⁾	
UNI 2.2 R7 R54-5 (-ET)	UNI-E 2.2 R7 R24	➔	BFP 21 R5	071N0173 ²⁾	

2) Important: These pumps are delivered for two-pipe operation. If the pumps are mounted on a one-pipe system, the changeover screw must be removed (fig. page 6) and the return port must be stopped with a metal plug.

Oil pumps – Eckerle

Eckerle		➔	Danfoss oil pumps		
Old designation	New designation	➔	Type	Code no.	Comments/accessories
UNI 2.2 R7 R56-H-ET	UNI-E 2.2 R7 R24	➔	BFP 21 R5	071N0173 ²⁾	
UNI 2.3 L1 L56 (W-1-05)	UNI-E 2.3 L1 L26-80	➔	BFP 20 L3	071N0168 ²⁾	Eckerle: 10-25 bar BFP: max. 20 bar + flange: 071N0047
UNI 2.3 L1 R54	UNI-E 2.3 L1 R24-13	➔	BFP 20 L3	071N0168 ²⁾	Eckerle: 10-25 bar, BFP: max 20 bar
	UNI-E L5 L24-13	➔	BFP 20 L5	071N0126 ²⁾	Eckerle: max 25 bar, BFP: max 20 bar
UNI 2.3 L5 L54	UNI-E 2.3 L5 L24-13	➔	BFP 20 L5	071N0126 ²⁾	Eckerle: 10-25 bar, BFP: max 20 bar
UNI 2.3 L5 L56-I (W-06)	UNI-E 2.3 L5 L26-80	➔	BFP 20 L5	071N0126 ²⁾	Eckerle: 10-25 bar, BFP: max 20 bar + flange: 071N0047
	UNI-E 2.3 L5 L64	➔	BFP 20 L5	071N0126 ²⁾	Eckerle: G 1/8 in S+R
UNI 2.3 L5 R54-S	UNI-E 2.3 L5 R24-13	➔	BFP 20 L5	071N0126 ²⁾	
UNI 2.3 R5 L54-05	UNI-E 2.3 R5 L24	➔	BFP 20 R5	071N0129 ²⁾	Eckerle: max 25 bar, BFP: max 20 bar
	UNI-E 2.3 R5 R24-13	➔	BFP 20 R5	071N0129 ²⁾	
UNI 2.3 R5 R54		➔	BFP 20 R5	071N0129 ²⁾	Eckerle: 10-25 bar, BFP: max 20 bar
UNI 2.3 R5 R64-I	UNI-E 2.3 R5 R24-93	➔	BFP 20 R5	071N0129 ²⁾	Eckerle: max 25 bar, BFP: max 20 bar
UNI 2.3 R6 L55-05	UNI-E 2.3 R6 L25	➔	BFP 20 R5	071N0129 ²⁾	Eckerle: max 75 l/h, BFP: 40 l/h at 12 bar
UNI 2.4 L1 M10-VO	UNI-E 2.4 L1 M10-22	➔	BFP 52E L3	071N2201 ^{2) 4)}	+ coupling with single flat in hole (D-shaped)
UNI 2.4 L1 M14-C1	UNI-E 2.4 L1 M14-12	➔	BFP 52E L3	071N2201 ^{2) 4)}	
UNI 2.4 L1 R14-C		➔		No repl.	
UNI 2.4 L1 R14-V1-21	UNI-E 2.4 L1 R14-12	➔		No repl.	Righthand nozzle output on Eckerle
UNI 2.4 L1 R44	UNI-E 2.4 L1 R14	➔		No repl.	
	UNI-E 2.4 L5 L20	➔	BFP 52E L5	071N2202 ^{2) 4)}	+ coupling with single flat in hole (D-shaped)
UNI 2.4 L5 L24	UNI-E 2.4 L5 L24	➔	BFP 52E L5	071N2202 ^{2) 4)}	
	UNI-E 2.4 L5 M20	➔	BFP 52E L5	071N2202 ^{2) 4)}	+ coupling with single flat in hole (D-shaped)
UNI 2.4 L5 M24		➔	BFP 52E L5	071N2202 ²⁾	
UNI 2.4 L5 M20-21	UNI-E 2.4 L5 M20	➔	BFP 52E L5	071N2202 ^{2) 4)}	+ coupling with single flat in hole (D-shaped)

2) Important: These pumps are delivered for two-pipe operation. If the pumps are mounted on a one-pipe system, the changeover screw must be removed (fig. page 6) and the return port must be stopped with a metal plug.

4) The pump NC valve must be connected in parallel to the NC valve in the nozzle line.

Oil pumps – Eckerle

Eckerle		➔	Danfoss oil pumps		
Old designation	New designation	➔	Type	Code no.	Comments/accessories
UNI 2.4 L5 R24		➔		No repl.	Righthand nozzle output on Eckerle
UNI 2.4 L5 R24		➔		No repl.	Righthand nozzle output on Eckerle
UNI 2.4 L5 S24	UNI-E 2.4 L5 S24	➔		No repl.	
UNI 2.4 R5 L24		➔	BFP 52E R5	071N2204 ⁴⁾	
UNI 2.4 R5 L24-05	UNI-E 2.4 R5 L24	➔	BFP 52E R5	071N2204 ⁴⁾	
UNI 2.4 R5 R24	UNI-E 2.4 R5 R24	➔		No repl.	Righthand nozzle output on Eckerle
UNI 2.4 R5 S70		➔		No repl.	
UNI 2.4 R5 S70-ET	UNI-E 2.4 R5 S70	➔		No repl.	
UNI 2.4 R5.5 L24	UNI-E 2.4 R5.5 L24	➔		No repl.	
UNI 2.4 L6 L22	UNI-E 2.4 L6 L22	➔	BFP 52E L5	071N2202 ⁴⁾	Eckerle: max 75 l/h, BFP: max. 40 l/h at 12 bar + bush: 071B0011
UNI 2.4 L6 L24		➔	BFP 52E L5	071N2202 ⁴⁾	Eckerle: max 75 l/h, BFP: max. 40 l/h at 12 bar
UNI 2.4 L6 L24-05	UNI-E 2.4 L6 L24	➔	BFP 52E L5	071N2202 ⁴⁾	
UNI 2.4 L6 M24-C1	UNI-E 2.4 L6 M24-12	➔	BFP 52E L5	071N2202 ⁴⁾	
UNI 2.4 R6 S24		➔		No repl.	Righthand nozzle output on Eckerle
UNI 2.4 R6 S24 ET	UNI-E 2.4 R6 S24	➔		No repl.	
UNI 2.4 L7 L23	UNI-E 2.4 L7 L22	➔	BFP 52E L5	071N2202 ⁴⁾	Eckerle: 120 l/h, BFP 40 l/h at 12 bar + 071N0047 + coupling with single flat in hole (D-shaped)
UNI 2.4 L7 L24		➔	BFP 52E L5	071N2202 ⁴⁾	Eckerle: max 120 l/h, BFP: max. 40 l/h at 12 bar
UNI 2.4 L7 L24-05	UNI-E 2.4 L7 L24	➔	BFP 52E L5	071N2202 ⁴⁾	
UNI 2.4 L7 L25-K	UNI-E 2.4 L7 L25-20	➔	BFP 52E L5	071N2202 ⁴⁾	Eckerle: max 120 l/h, BFP: max. 40 l/h at 12 bar + bush: 071B0011
UNI 2.4 L7 L26		➔	BFP 52E L5	071N2202 ⁴⁾	Eckerle: max 120 l/h, BFP: max. 40 l/h at 12 bar

4) The pump NC valve must be connected in parallel to the NC valve in the nozzle line.

Oil pumps – Eckerle

Eckerle		➔	Danfoss oil pumps		
Old designation	New designation	➔	Type	Code no.	Comments/accessories
UNI 2.4 L7 L58	UNI-E 2.4 L7 L26 (-05)	➔	BFP 52E L5	071N2202 ⁴⁾	Eckerle: max 120 l/h, BFP: max. 40 l/hbei 12 bar + cable + flange: 071N0047
UNI 2.4 L7 M26	UNI-E 2.4 L7 M25	➔	BFP 52E L5	071N2202 ⁴⁾	Eckerle: max 120 l/h, BFP: max 40 l/hbei 12 bar + flange: 071N0047
UNI 2.4 R7 R54-06	UNI-E 2.4 R7 R24	➔		No repl.	Eckerle: Righthand nozzle output on Eckerle
UNI 2.42 R5 R70-ET	UNI-E 2.42 R5 R70	➔		No repl.	
	UNI-E 2.42 L5 L64-65	➔	BFP 52E L5	071N2202	Eckerle: G 1/8 in S+R
	UNI-E 2.6 L5 L14	➔	BFP 20 L5	071N0126 ²⁾	
UNI 2.6 L5 L44		➔	BFP 20 L5	071N0126 ²⁾	Possible changeover to 1-pipe operation
	UNI-E 2.6 L6 L14	➔	BFP 20 L5	071N0126 ²⁾	Eckerle: 75 l/h, BFP: 40 l/h at 12 bar
	UNI-E 2.6 L6 L14	➔	BFP 20 L5	071N0126 ²⁾	
UNI 2.6 L6 L44		➔		No repl.	
UNI 2.6 Stage 6		➔		No repl.	
UNI 2.6 Stage 7		➔		No repl.	
UNI 2.7 L5 L44		➔	BFP 20 L5	071N0126 ²⁾	
UNI 2.7 R5 R44	UNI-E 2.7 R5 R14	➔	BFP 20 R5	071N0129 ²⁾	
UNI 2.8 L5 L16		➔	BFP 21 L5	071N0172 ²⁾	BFP without remote setting + flange: 071N0047
UNI 2.91 L5 L44	UNI-E 2.91 L5 L14	➔		No repl.	
UNI 2.91 L7 L44-05	UNI-E 2.91 L7 L14	➔		No repl.	
UNI 2.91 R7 L44	UNI-E 2.91 R7 L14	➔		No repl.	
UNI 2.93 L1 R44	UNI-E 2.93 L1 R14	➔		No repl.	
UNI 2.96 L5 L44-05	UNI-E 2.96 L5 L14	➔		No repl.	
UNI 2.96 L7 L44	UNI-E 2.96 L7 L14	➔		No repl.	
UNI 2.10 L7 L56-S-W	UNI-E 2.10 L7 L26-11	➔	RSA 60	070L3362	+ flange: 070-0211
UNI 2.10 L7 L56-W1-05	UNI-E 2.10 L7 L26-11	➔	RSA 60	070L3362	
UNI 2.10 L8 L56-S-W	UNI-E 2.10 L8 L26-11	➔	RSA 95	070L3482	

2) Important: These pumps are delivered for two-pipe operation. If the pumps are mounted on a one-pipe system, the changeover screw must be removed (fig. page 6) and the return port must be stopped with a metal plug.

4) The pump NC valve must be connected in parallel to the NC valve in the nozzle line.

Oil pumps – Eckerle

Eckerle		➔	Danfoss oil pumps		
Old designation	New designation	➔	Type	Code no.	Comments/accessories
UNI 2.10 L8 L56-W1-05	UNI-E 2.10 L8 L26-11	➔	RSA 95	070L3482	+ flange: 070-0211
UNI 2.12 L1 L14		➔	BFP 21 L3	071N0156 ⁶⁾	
UNI 2.12 L1 L64		➔	BFP 21 L3	071N0156 ⁶⁾	Eckerle: G 1/8 in S+R
UNI 2.12 L1 M14		➔	BFP 21 L3	071N0156 ⁶⁾	
UNI 2.12 L1 M64		➔	BFP 21 L3	071N0156 ⁶⁾	Eckerle: G 1/8 in S+R
UNI 2.12 L1 M64-65		➔	BFP 21 L3	071N0156 ⁶⁾	
UNI 2.12 L6 M14		➔	BFP 21 L5	071N0172 ²⁾	
UNI 2.12 L6 M14-65		➔	BFP 21 L5	071N0172 ²⁾	Eckerle: 75 l/h, BFP: 40 l/h at 12 bar
UNI 2.13 L8 L56-S	UNI-E 2.13 L8 L26-11	➔		No repl.	
UNI 2.17 L6 M14-65		➔		No repl.	
UNI 2.20 11L7 L26-W-01	UNI-E 2.20 L7 L26	➔		No repl.	

2) Important: These pumps are delivered for two-pipe operation. If the pumps are mounted on a one-pipe system, the changeover screw must be removed (fig. page 6) and the return port must be stopped with a metal plug.

6) If the pump is wanted delivered incl. cable, bush and flange, please order 071N0132.

Oil pumps – DELTA

DELTA			➔	Danfoss oil pumps		
Type	Code no.	1 or 2 pipe	➔	Type	Code no.	Remarks
V	V1LR2 4 (or 5)	2	➔	BFP 20 L3	071N0168 ²⁾	
V	V1LR1 4 (or 5)	1	➔	BFP 20 L3	071N0168 ²⁾	
V	V1LL2 4 (or 5)	2	➔	BFP 20 L3	071N0168 ²⁾	
V	V1LL1 4 (or 5)	1	➔	BFP 20 L3	071N0168 ²⁾	
V	V1RL2 4 (or 5)	2	➔	BFP 20 R3	071N0169 ²⁾	
V	V1RL1 4 (or 5)	1	➔	BFP 20 R3	071N0169 ²⁾	
V	V1RR2 4 (or 5)	2	➔	BFP 20 R3	071N0169 ²⁾	
V	V1RR1 4 (or 5)	1	➔	BFP 20 R3	071N0169 ²⁾	
V	V2LR2 4 (or 5)	2	➔	BFP 20 L5	071N0126 ²⁾	
V	V2LR1 4 (or 5)	1	➔	BFP 20 L5	071N0126 ²⁾	
V	V2LL2 4 (or 5)	2	➔	BFP 20 L5	071N0126 ²⁾	
V	V2LL1 4 (or 5)	1	➔	BFP 20 L5	071N0126 ²⁾	
V	V2RL2 4 (or 5)	2	➔	BFP 20 R5	071N0129 ²⁾	
V	V2RL1 4 (or 5)	1	➔	BFP 20 R5	071N0129 ²⁾	
V	V2RR2 4 (or 5)	2	➔	BFP 20 R5	071N0129 ²⁾	
V	V2RR1 4 (or 5)	1	➔	BFP 20 R5	071N0129 ²⁾	
V	VU 3 ...				No repl.	Delta 75 l/h at 10 bar
V	VU 4 ...				No repl.	Delta 95 l/h at 10 bar
V	VU 5 ...				No repl.	Delta 110 l/h at 10 bar

2) Important: These pumps are delivered for two-pipe operation. If the pumps are mounted on a one-pipe system, the changeover screw must be removed (fig. page 6) and the return port must be stopped with a metal plug.

Oil pumps – DELTA

DELTA			➔	Danfoss oil pumps		
Type	Code no.	1 or 2 pipe	➔	Type	Code no.	Remarks
VD	VD1LR2 4 (or 5)	2	➔	BFP 20 L3	071N0168 ²⁾	
VD	VD1LR1 4 (or 5)	1	➔	BFP 20 L3	071N0168 ²⁾	
VD	VD1LL2 4 (or 5)	2	➔	BFP 20 L3	071N0168 ²⁾	
VD	VD1LL1 (4 or 5)	1	➔	BFP 20 L3	071N0168 ²⁾	
VD	VD1RL2 4 (or 5)	2	➔	BFP 20 R3	071N0169 ²⁾	
VD	VD1RL1 4 (or 5)	1	➔	BFP 20 R3	071N0169 ²⁾	
VD	VD1RR2 4 (or 5)	2	➔	BFP 20 R3	071N0169 ²⁾	
VD	VD1RR1 4 (or 5)	1	➔	BFP 20 R3	071N0169 ²⁾	
VD	VD2LR2 4 (or 5)	2	➔	BFP 20 L5	071N0126 ²⁾	
VD	VD2LR1 4 (or 5)	1	➔	BFP 20 L5	071N0126 ²⁾	
VD	VD2LL2 4 (or 5)	2	➔	BFP 20 L5	071N0126 ²⁾	
VD	VD2LL1 4 (or 5)	1	➔	BFP 20 L5	071N0126 ²⁾	
VD	VD2RL2 4 (or 5)	2	➔	BFP 20 R5	071N0129 ²⁾	
VD	VD2RL1 4 (or 5)	1	➔	BFP 20 R5	071N0129 ²⁾	
VD	VD2RR2 4 (or 5)	2	➔	BFP 20 R5	071N0129 ²⁾	
VD	VD2RR1 4 (or 5)	1	➔	BFP 20 R5	071N0129 ²⁾	
VD	VD 3 ...				No repl.	Delta 75 l/h at 10 bar
VD	VD 4 ...				No repl.	Delta 95 l/h at 10 bar

2) Important: These pumps are delivered for two-pipe operation. If the pumps are mounted on a one-pipe system, the changeover screw must be removed (fig. page 6) and the return port must be stopped with a metal plug.

Oil pumps – DELTA

DELTA			➔	Danfoss oil pumps		
Type	Code no.	1 or 2 pipe	➔	Type	Code no.	Remarks
VM	VM1LR2 4 (or 5) F84-220	2	➔	BFP 21 L3	071N0156 ^{6) 7)}	F84-220: Indicates coil with loose cable and for 220 V, 50 Hz. If using other voltages the following must be ordered extra: Coil no. 071N0061 for 110/120 VAC or Coil no. 071N0062 for 24 VAC NB: VM1 and VM2 are delivered with G ¹ / ₈ and G ¹ / ₄ respectively in the suction and the return outlet.
VM	VM1LR1 4 (or 5) F84-220	1	➔	BFP 21 L3	071N0156 ⁶⁾	
VM	VM1LL2 4 (or 5) F84-220	2	➔	BFP 21 L3	071N0156 ^{6) 7)}	
VM	VM1LL1 4 (or 5) F84-220	1	➔	BFP 21 L3	071N0156 ⁶⁾	
VM	VM1RL2 4 (or 5) F84-220	2	➔	BFP 21 R3	071N0157 ⁷⁾	
VM	VM1RL1 4 (or 5) F84-220	1	➔	BFP 21 R3	071N0157	
VM	VD1RR2 4 (or 5) F84-220	2	➔	BFP 21 R3	071N0157 ⁷⁾	
VM	VM1RR1 4 (or 5) F84-220	1	➔	BFP 21 R3	071N0157	
VM	VM2LR2 4 (or 5) F84-220	2	➔	BFP 21 L5	071N0172 ²⁾	
VM	VM2LR1 4 (or 5) F84-220	1	➔	BFP 21 L5	071N0172 ²⁾	
VM	VM2LL2 4 (or 5) F84-220	2	➔	BFP 21 L5	071N0172 ²⁾	
VM	VM2LL1 4 (or 5) F84-220	1	➔	BFP 21 L5	071N0172 ²⁾	
VM	VM2RL2 4 (or 5) F84-220	2	➔	BFP 21 R5	071N0173 ²⁾	
VM	VM2RL1 4 (or 5) F84-220	1	➔	BFP 21 R5	071N0173 ²⁾	
VM	VM2RR2 4 (or 5) F84-220	2	➔	BFP 21 R5	071N0173 ²⁾	
VM	VM2RR1 4 (or 5) F84-220	1	➔	BFP 21 R5	071N0173 ²⁾	
VM	VM 3 ...			No repla.	Delta 75 l/h at 10 bar	

2) Important: These pumps are delivered for two-pipe operation. If the pumps are mounted on a one-pipe system, the changeover screw must be removed (fig. page 6) and the return port must be stopped with a metal plug.

6) If the pump is wanted delivered incl. cable, bush and flange, please order 071N0132.

7) This pump is for one-pipe operation. On pumps for two-pipe operation the changeover screw must be fitted.

Oil pumps – DELTA

DELTA			➔	Danfoss oil pumps		
Type	Code no.	1 or 2 pipe	➔	Type	Code no.	Remarks
VM	VM1LR2 4 (or 5) M8-220	2	➔	BFP 21 L3	071N0156 ^{6) 7)}	M8-220: Indicates coil with fixed cable and for 220 V, 50 Hz. Generally the following cable should be ordered here: Cable no. 071G0200 L = 500 mm or Cable no. 071G0202 L = 280 mm or Cable no. 071G0204 L = 710 mm If using other voltages the following must be ordered extra: Coil no. 071N0061 for 110/120 VAC or Coil no. 071N0062 for 24VAC NB: VM1 and VM2 are delivered with G ¹ / ₈ and G ¹ / ₄ respectively in the suction and the return outlet.
VM	VM1LR1 4 (or 5) M8-220	1	➔	BFP 21 L3	071N0156 ⁶⁾	
VM	VM1LL2 4 (or 5) M8-220	2	➔	BFP 21 L3	071N0156 ^{6) 7)}	
VM	VM1LL1 4 (or 5) M8-220	1	➔	BFP 21 L3	071N0156 ⁶⁾	
VM	VM1RL2 4 (or 5) M8-220	2	➔	BFP 21 R3	071N0157 ⁷⁾	
VM	VM1RL1 4 (or 5) M8-220	1	➔	BFP 21 R3	071N0157	
VM	VD1RR2 4 (or 5) M8-220	2	➔	BFP 21 R3	071N0157 ⁷⁾	
VM	VM1RR1 4 (or 5) M8-220	1	➔	BFP 21 R3	071N0157	
VM	VM2LR2 4 (or 5) M8-220	2	➔	BFP 21 L5	071N0172 ²⁾	
VM	VM2LR1 4 (or 5) M8-220	1	➔	BFP 21 L5	071N0172 ²⁾	
VM	VM2LL2 4 (or 5) M8-220	2	➔	BFP 21 L5	071N0172 ²⁾	
VM	VM2LL1 4 (or 5) M8-220	1	➔	BFP 21 L5	071N0172 ²⁾	
VM	VM2RL2 4 (or 5) M8-220	2	➔	BFP 21 R5	071N0173 ²⁾	
VM	VM2RL1 4 (or 5) M8-220	1	➔	BFP 21 R5	071N0173 ²⁾	
VM	VM2RR2 4 (or 5) M8-220	2	➔	BFP 21 R5	071N0173 ²⁾	
VM	VM2RR1 4 (or 5) M8-220	1	➔	BFP 21 R5	071N0173 ²⁾	
VM	VM 3 ...			No repla.	Delta 75 l/h at 10 bar	

2) Important: These pumps are delivered for two-pipe operation. If the pumps are mounted on a one-pipe system, the changeover screw must be removed (fig. page 6) and the return port must be stopped with a metal plug.

6) If the pump is wanted delivered incl. cable, bush and flange, please order 071N0132.

7) This pump is for one-pipe operation. On pumps for two-pipe operation the changeover screw must be fitted.

Oil pumps – DELTA

DELTA			➔	Danfoss oil pumps		
Type	Code no.	1 or 2 pipe	➔	Type	Code no.	Remarks
VMK	VMK1LR2 4-6 / F84-220	2	➔	BFP 52E L3	071N02201 ⁴⁾	<p>F84-220: Indicates coil with loose cable and for 220 V, 50 Hz.</p> <p>BFP52E is not delivered for other voltages.</p> <p>NB: VMK1 and VMK2 are delivered with G¹/₈ and G¹/₄ respectively in the suction and the return outlet.</p>
VMK	VMK1LR1 4-6 / F84-220	1	➔	BFP 52E L3	071N02201 ⁴⁾	
VMK	VMK1LL2 4-6 / F84-220	2	➔		No repl.	
VMK	VMK1LL1 4-6 / F84-220	1	➔		No repl.	
VMK	VMK1RL2 4-6 / F84-220	2	➔		No repl.	
VMK	VMK1RL1 4-6 / F84-220	1	➔		No repl.	
VMK	VMK1RR2 4-6 / F84-220	2	➔	BFP 52E R3	071N2203 ⁴⁾	
VMK	VMK1RR1 4-6 / F84-220	1	➔	BFP 52E R3	071N2203 ⁴⁾	
VMK	VMK2LR2 4-6 / F84-220	2	➔	BFP 52E L5	071N2202 ⁴⁾	
VMK	VMK2LR1 4-6 / F84-220	1	➔	BFP 52E L5	071N2202 ⁴⁾	
VMK	VMK2LL2 4-6 / F84-220	2	➔		No repl.	
VMK	VMK2LL1 4-6 / F84-220	1	➔		No repl.	
VMK	VMK2RL2 4-6 / F84-220	2	➔		No repl.	
VMK	VMK2RL1 4-6 / F84-220	1	➔		No repl.	
VMK	VMK2RR2 4-6 / F84-220	2	➔	BFP 52E R5	071N2204 ⁴⁾	
VMK	VMK2RR1 4-6 / F84-220	1	➔	BFP 52E R5	071N2204 ⁴⁾	
VMK	VMK 3 ...				No repl.	Delta 75 l/h at 10 bar

4) The NC-solenoid coil must be connected in parallel with the burner motor.

Oil pumps – DELTA

DELTA			➔	Danfoss oil pumps		
Type	Code no.	1 or 2 pipe	➔	Type	Code no.	Remarks
VMK	VMK1LR2 4-6 / M8-220	2	➔	BFP 52E L3	071N02201 ⁴⁾	<p>M8-220: Indicates coil with fixed cable and for 220 V, 50 Hz. Generally the following cable should be ordered here: Cable no. 071G0200 L = 500 mm for the NC-valve or Cable no. 071G0202 L = 280 mm for the NC-valve or Cable no. 071G0204 L = 710 mm for the NC-valve and Cable no. 071G0201 L = 500 mm for the NO-valve or Cable no. 071G0203 L = 280 mm for the NO-valve or Cable no. 071G0205 L = 710 mm for the NO-valve</p> <p>BFP52E is not delivered for other voltages.</p> <p>NB: VMK1 and VMK2 are delivered with G¹/₈ and G¹/₄ respectively in the suction and the return outlet.</p>
VMK	VMK1LR1 4-6 / M8-220	1	➔	BFP 52E L3	071N02201 ⁴⁾	
VMK	VMK1LL2 4-6 / M8-220	2	➔		No repl.	
VMK	VMK1LL1 4-6 / M8-220	1	➔		No repl.	
VMK	VMK1RL2 4-6 / M8-220	2	➔		No repl.	
VMK	VMK1RL1 4-6 / M8-220	1	➔		No repl.	
VMK	VMK1RR2 4-6 / M8-220	2	➔	BFP 52E R3	071N2203 ⁴⁾	
VMK	VMK1RR1 4-6 / M8-220	1	➔	BFP 52E R3	071N2203 ⁴⁾	
VMK	VMK2LR2 4-6 / M8-220	2	➔	BFP 52E L5	071N2202 ⁴⁾	
VMK	VMK2LR1 4-6 / M8-220	1	➔	BFP 52E L5	071N2202 ⁴⁾	
VMK	VMK2LL2 4-6 / M8-220	2	➔		No repl.	
VMK	VMK2LL1 4-6 / M8-220	1	➔		No repl.	
VMK	VMK2RL2 4-6 / M8-220	2	➔		No repl.	
VMK	VMK2RL1 4-6 / M8-220	1	➔		No repl.	
VMK	VMK2RR2 4-6 / M8-220	2	➔	BFP 52E R5	071N2204 ⁴⁾	
VMK	VMK2RR1 4-6 / M8-220	1	➔	BFP 52E R5	071N2204 ⁴⁾	
VMK	VMK 3 ...				No repl.	Delta 75 l/h at 10 bar

4) The NC-solenoid coil must be connected in parallel with the burner motor.

Dimensions – RSA

RSA 28 – RSA 40 – RSA 60

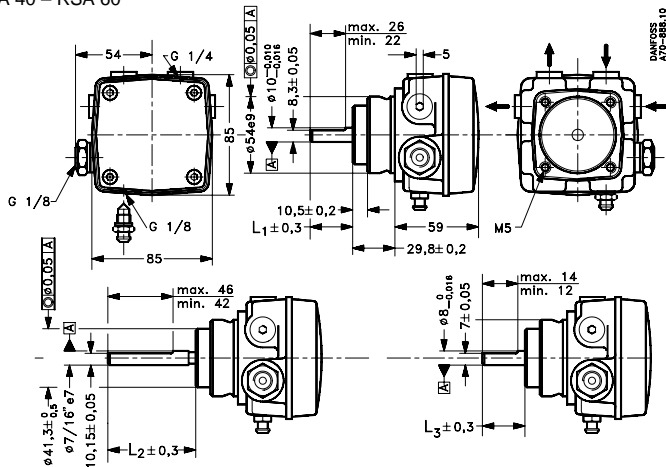

G 1/4 = R 1/4 = 1/4RG = 1/4 in BSPF

Type	L1	L2	L3
RSA 28	30,0	62,0	11,4
RSA 40	28,8	60,8	10,2
RSA 60	26,8	58,8	-

Accessories – RSA

RSA 28 – RSA 40 – RSA 60
Flange 070-0211

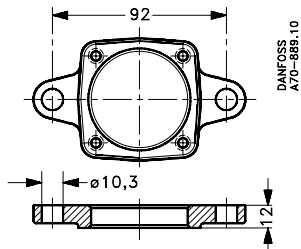

Type	L1	L2	L3
RSA 28	30,0	62,0	11,4
RSA 40	28,8	60,8	10,2
RSA 60	26,8	58,8	–

Dimensions – RSL

RSL 028

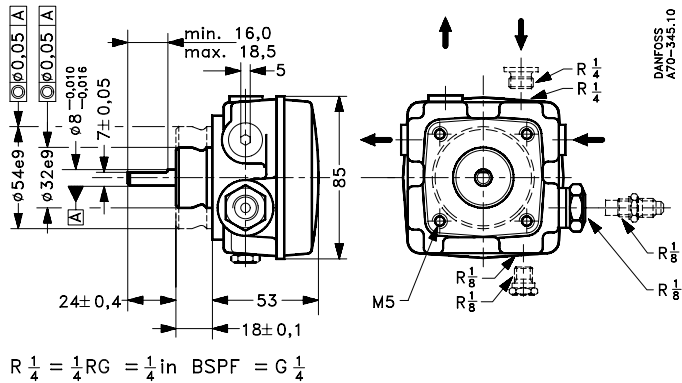

Dimensions – RSL

RSL 050

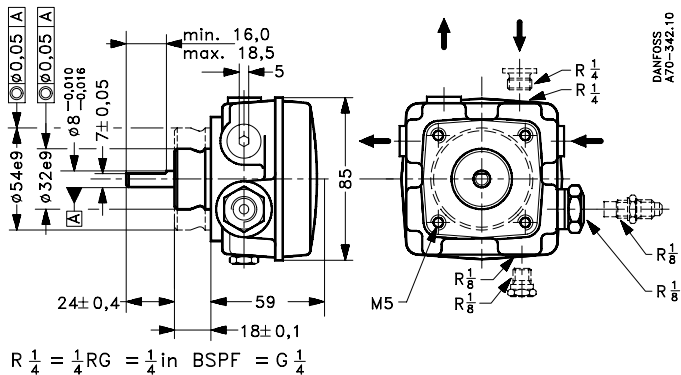

Dimensions – MSL

MSLA – MSLB – MSLC – MSLD

The illustrations show MSLA (MSLB, MSLC and MSLD are without solenoid valve and coil)

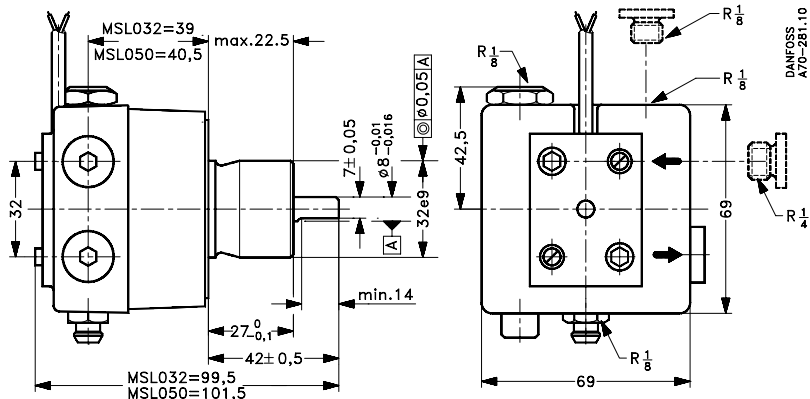

$$R \frac{1}{4} = \frac{1}{4}RG = \frac{1}{4}in \text{ BSPF} = G \frac{1}{4}$$

Dimensions – MS

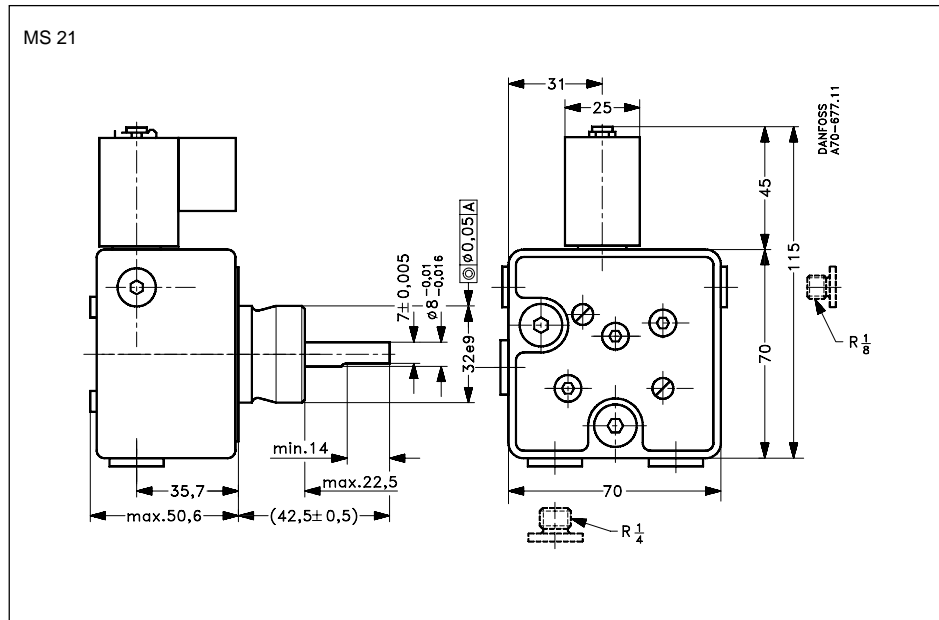

Dimensions – MS

MS 12E

MS 10: without solenoid valves

MS 11: without NO valve (dotted lines)

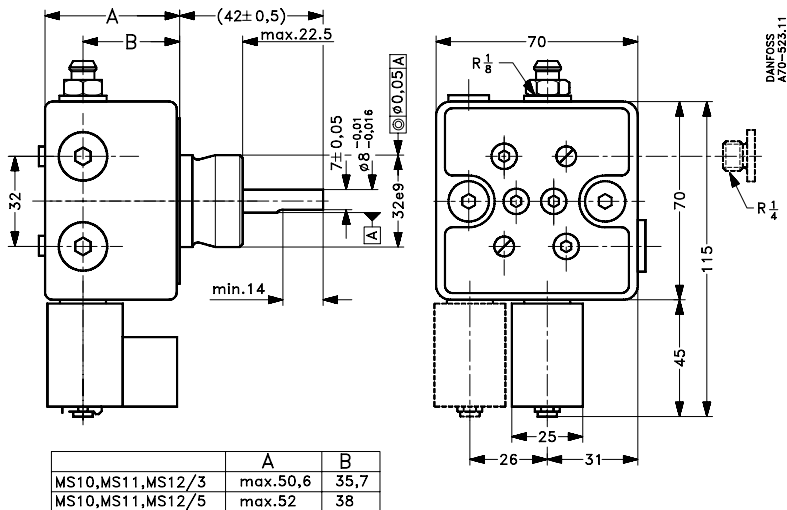

DANFOSS
A70-523.11

Dimensions – BFP

BFP 11R3

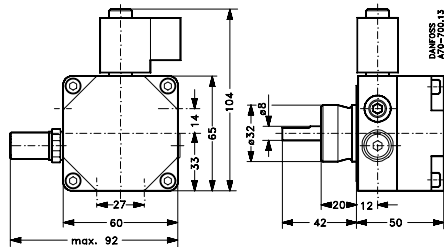

BFP 11L3

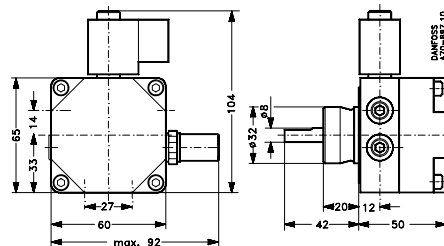

Dimensions – BFP

BFP 20

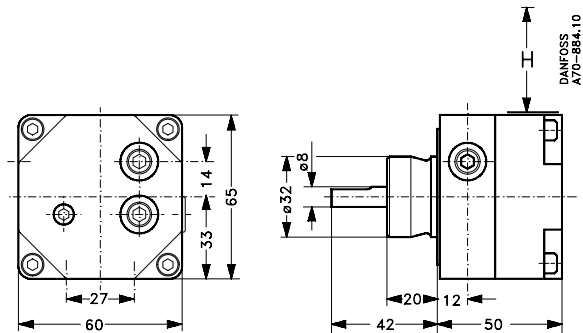

Min. 45 mm height clearance is necessary when replacing the cartridge filter.

Dimensions – BFP

BFP 21

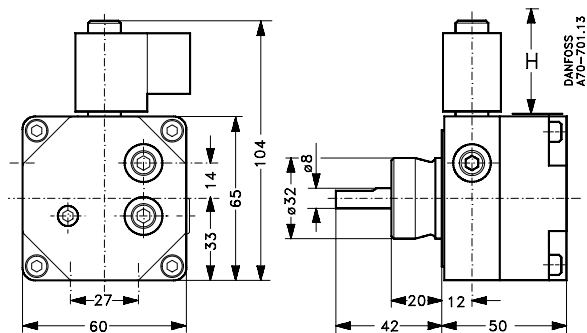

Min. 45 mm height clearance is necessary when replacing the cartridge filter.

Dimensions – BFP

BFP 41

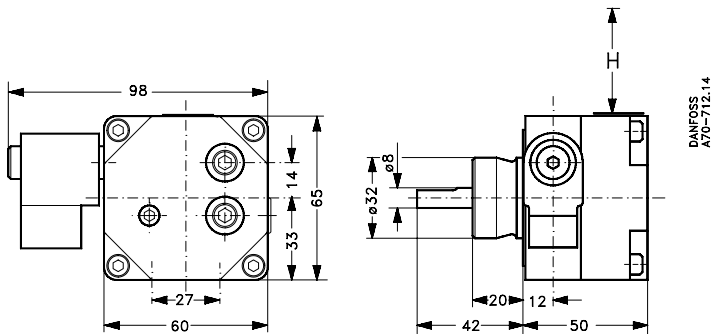

Min. 45 mm height clearance is necessary when replacing the cartridge filter.

Dimensions – BFP

BFP 52E

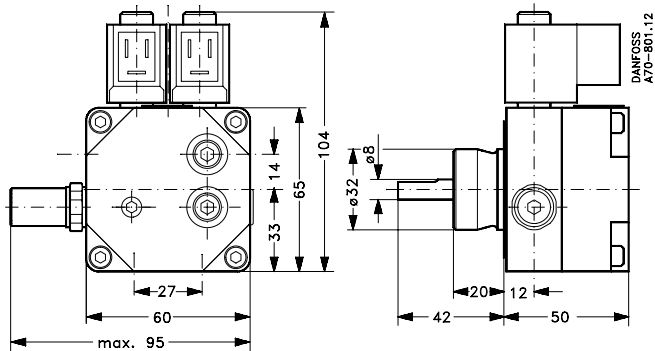

Min. 45 mm height clearance is necessary when replacing the cartridge filter.

Accessories – RSL / MSL / MS / BFP

Screws and bush
Code no. 071B0011

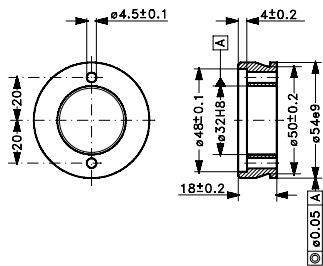
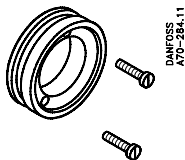

Screws, bush and flange
Code no. 071N0047

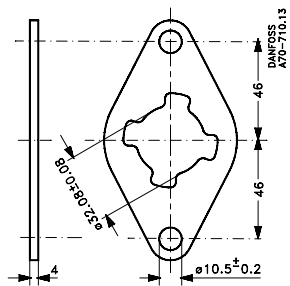
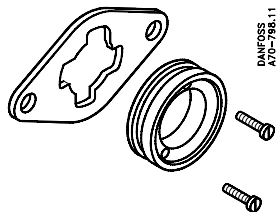

Connections – BFP

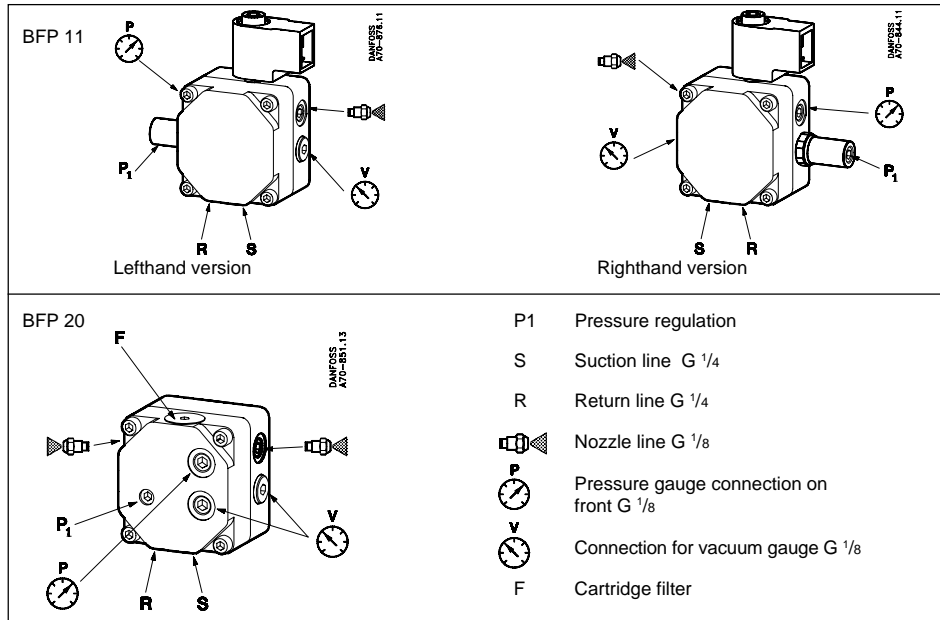

Connections – BFP

BFP 21

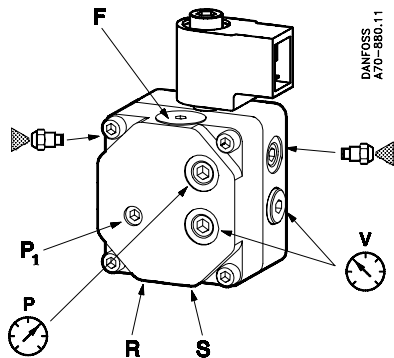



P1 Pressure regulation

S Suction line G 1/4

R Return line G 1/4

 Nozzle line G 1/8

 Pressure gauge connection on front G 1/8

 Connection for vacuum gauge G 1/8

F Cartridge filter

Connections – BFP

BFP 41

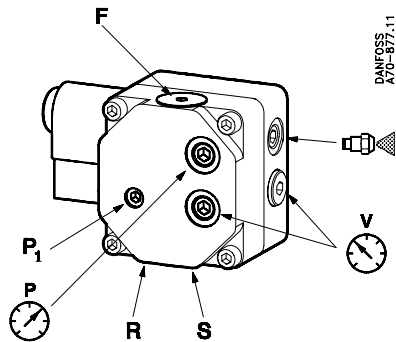



P1 Pressure regulation

S Suction line G 1/4

R Return line G 1/4

 Nozzle line G 1/8

 Pressure gauge connection on front G 1/8



 Connection for vacuum gauge G 1/8

F Cartridge filter

Connections – BFP

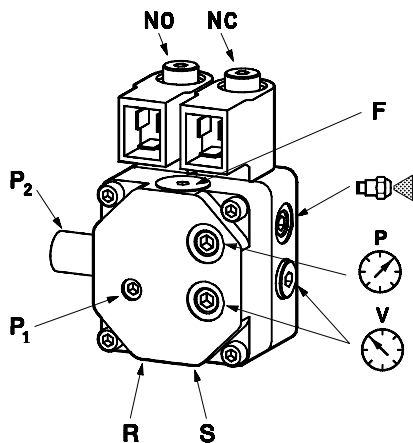
BFP 52E



- | | |
|---|--|
| P1 | Pressure regulation 1 |
| P2 | Pressure regulation 2 |
| S | Suction line G 1/4 |
| R | Return line G 1/4 |
|  | Nozzle line G 1/8 |
|  | Pressure gauge connection on front G 1/8 |
|  | Connection for vacuum gauge G 1/8 |
| F | Cartridge filter |

DANFOSS
A70-820.11

2. Oil burner control conversion

Contents

Introduction	Page 57
Conversion	57F, 57H, 57L -> BHO	Page 58
Conversion	BHO, older series -> BHO	Page 58
Conversion	BHO 1 WLE and BHO 4 WLE -> LOA 44	Page 59
Conversion	BHO 21/25 and BHOV 22 -> LOA 44	Page 60
Conversion	LOA -> BHO	Page 61
Conversion	BHO -> BHO	Page 62
Dimensions	BHO	Page 63
Dimensions	Service pack A	Page 64
Accessories	BHO	Page 65

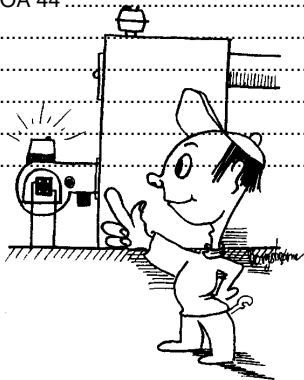

Oil burner controls conversion

Oil burner control conversions are given in the tables below:

The following old Danfoss oil burner controls can be replaced: types 57F, 57H, 57L and BHO.

According to the European standard EN 230, oil burner controls must in future have undervoltage protection.



BHO 64 incorporates this protection.

Therefore it is this oil burner control that most often replaces the old Danfoss types.

The overview is built up as follows:

- Column 1 always gives the old oil burner control types that are to be replaced.
- Column 2 gives the code numbers of the oil burner controls that are to be replaced.
- Column 4 gives the new types of Danfoss oil burner controls.
- Column 5 gives the corresponding code numbers.
- The last column gives the code numbers of the corresponding accessories.

Oil burner controls

Older Danfoss series		➔	Replacement Danfoss oil burner controls			
Type	Code no.	➔	Type	Code no.	Comments/accessories	
57F1	057F0001	➔	BHO 64	057H7036	+ 057H7010 + 057H7011 + 057H7087 + 057H7071 + 057H7072 (see page 63-64)	
57F3	057F0003	➔	BHO 64	057H7036		
57H1	057H0062	➔	BHO 64	057H7036		
57H1	057H0072	➔	BHO 64	057H7036	+ 057H7022 (see page 64)	
57H1	057H1002	➔	BHO 64	057H7036		
57H3	057H1003	➔	BHO 64	057H7036		
57H1 WLE	057H0042	➔	LOA 44	057H7040		
57H1	057H0052	➔	BHO 64	057H7036		
57H2	057H0053	➔	BHO 64	057H7036		
57H2	057H0063	➔	BHO 64	057H7036		
57H3	057H1005 ¹⁾	➔	BHO 64	057H7036		
57H3	057H0054 ¹⁾	➔	BHO 64.1	057H7037		+ 057H7010 + 057H7011 + 057H7087 + 057H7071 + 057H7072 (see page 62-63)
57H3	057H0064 ¹⁾	➔	BHO 64.1	057H7037		
57H5	057H0045	➔	LOA 44	057H7040	+ 057H7022 (see page 64)	
57H5	057H0055	➔	BHO 64	057H7036		
57H5	057H0065	➔	BHO 64	057H7036		
57H6	057H0032	➔		No repl.		
57L 1	057L0001	➔	BHO 64	057H7036	+ 057H7010 + 057H7011 + 057H7087 + 057H7071 + 057H7072 (see p. 63-64). Use motor starter on 380 V	
57L 1d	057L0002	➔	BHO 64	057H7036		
57L 3	057L0003	➔	BHO 64.1	057H7037		
57L 3d	057L0004	➔	BHO 64.1	057H7037		
BCG 1d	057L1001	➔		No repl.		
BCG 1d	057L1002	➔		No repl.		
BCG 1d	057L1003	➔		No repl.		
BCG 3,3d	057L1004	➔		No repl.		

1) Units supplied with L&G (Ståfa) reset button placing only

3) Preignition of 6 sec.

Oil burner controls

Older Danfoss series		➔	Replacement Danfoss oil burner controls		
Type	Code no.	➔	Type	Code no.	Comments/accessories
BCG 3.5d	057L1005	➔		No repl.	
BHO 1A	057H3013	➔	BHO 64	057H7036	+ 057H7022 (see page 64)
BHO 1B	057H3014	➔	BHO 64	057H7036	
BHO 1	057H3011	➔	BHO 64	057H7036	
BHO 1 WLE	057H3010	➔	LOA 44	057H7040	
BHO 1 WLE	057H3054	➔	LOA 44	057H7040	
BHO 3B	057H3018	➔	BHO 64.1	057H7037	
BHO 3B	057H3020	➔	BHO 64.1	057H7037	
BHO 4	057H4104	➔	BHO 64	057H7036	
BHO 4B	057H4144	➔	BHO 64	057H7036	
BHO 4 WLE	057H4110	➔	LOA 44	057H7040	
BHO 4.1	057H3012	➔	BHO 64	057H7036	
BHO 4.1B	057H3039	➔	BHO 64	057H7036	
BHO 4.1B	057H3044	➔	BHO 64	057H7036	
BHO 5	057H4105	➔	BHO 64	057H7036	
BHO 5.1	057H3015	➔	BHO 64	057H7036	
BHO 6	057H3032	➔		No repl.	
BHO 11	057H2011	➔	BHO 64	057H7036	+ 057H7022 (see page 64)
BHO 11.1	057H2011	➔	BHO 64	057H7036	
BHO 11.1	057H2013	➔	BHO 64	057H7036	
BHO 11.1	057H2014	➔	BHO 64	057H7036	
BHO 12	057H2031	➔	BHO 64	057H7036	
BHO 12	057H2012	➔	BHO 64	057H7036	
BHO 12.1	057H2005	➔	BHO 64	057H7036	
BHO 12.1	057H2012	➔	BHO 64	057H7036	

3) Preignition of 6 sec.

Oil burner controls

Older Danfoss series		➔	Replacement Danfoss oil burner controls		
Type	Code no.	➔	Type	Code no.	Comments/accessories
BHO 15	057H2015	➔	BHO 64	057H7036	+ 057H7010 + 057H7011 + 057H7079 + 057H7071 + 057H7072 (see page 63-64)
BHO 21	057H2042	➔	LOA 44	057H7040	
BHO 25	057H2045	➔	LOA 44	057H7040	+ 057H7022 (see page 64)
BHOV 1	057H3016	➔	BHO 64	057H7036	
BHOV 4	057H3030	➔	BHO 64	057H7036	
BHOV 4A	057H3033	➔	BHO 64	057H7036	
BHOV 4B	057H3034	➔	BHO 64	057H7036	
BHOV 12.2	057H2030	➔	BHO 64	057H7036	
BHOV 12.2	057H2033	➔	BHO 64	057H7036	
BHOV 12.2	057H2034	➔	BHO 64	057H7036	
BHOV 22	057H2054	➔	LOA 44	057H7040	Not supplied by Danfoss
FRA	086B0090	➔	LAE 10 LFE 10	Landis Stäfa	
FRU	086B0091	➔	LFE	Landis Stäfa	Not supplied by Danfoss

2) Ionisation

Oil burner controls

Landis & Gyr		➔	Replacement Danfoss oil burner controls		
Type	Code no.	➔	Type	Code no.	Comments/accessories
LOA 21.1	71B27	➔	BHO 64	057H7036	
LOA 21.1	73A27	➔	BHO 64A ⁴⁾	057H7030	
LOA 22.1	71B27	➔	BHO 64	057H7036	
LOA 22	"DF"	➔	BHO 64	057H7036	
LOA 24.1	71B27	➔	BHO 64	057H7036	
LOA 24.5	71C27	➔	BHO 64	057H7037	
LOA 44.2	52A27	➔	LOA 44	057H7040	

4) Post ignition 2 sec.

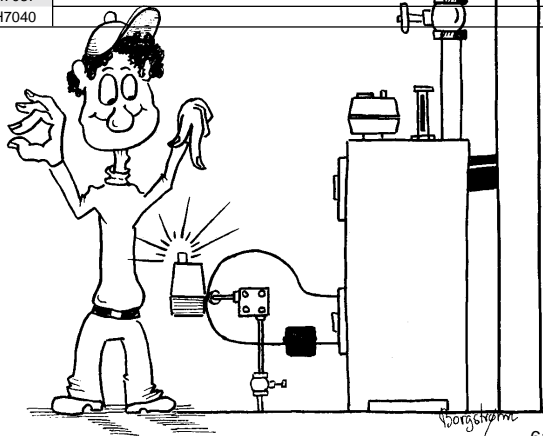

Oil burner controls

BHO			➡	BHO		
Type	Code no.	Comments/ accessories	➡	Type	Code no.	Comments/ accessories
BHO 61A	057H7031		➡	BHO 64A ⁴⁾	057H7030	
BHO 61	057H7032		➡	BHO 64	057H7036	
BHO 62	057H7034		➡	BHO 64	057H7036	
BHO 62D	057H7035		➡	BHO 64	057H7036	
BHO 64	057H7036		➡	BHO 64	057H7036	
BHO 64A	057H7030		➡	BHO 64A ⁴⁾	057H7030	
BHO 64.1	057H7037		➡	BHO 64.1	057H7037	

4) Post ignition 2 sec.

Defective components	Replacement components 7000 series code no.
Older oil burner controls	BHO 60 series + photo unit
BHO 60 series	BHO 60 series only
Old LD/LDS 057H0020 etc. 057H2000 series	BHO 60 series + photo unit
New LD/LDS 057H7000 series	Photo unit only

In burners without solenoid valve the motor must be connected to the solenoid valve terminals so that instead of prepurge, only pre-ignition takes place.

E.g. during maintenance work on the burner, if the oil burner control or photo unit shows defects it must be noted that there are different series of these components. In some circumstances both components must be replaced even though only one of them is defective. See table.

Units supplied with L&G (Stäfa) reset button placing only.

Dimensions - BHO

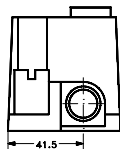
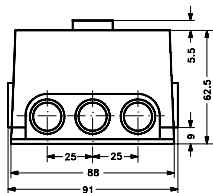

Oil burner control
057H7036

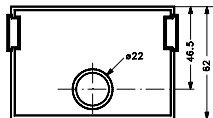

Danfoss
A07-535.10

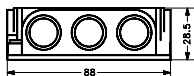

Cable entry
057H7011

Danfoss
A07-572.10

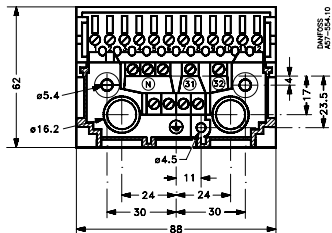

Base 057H7010
The cross-hatched part
can be replaced.

Danfoss
A07-554.10

Dimensions - service pack A 057H7022

Contents

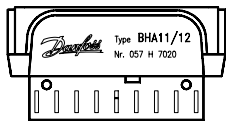

057H7020

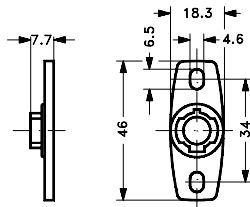
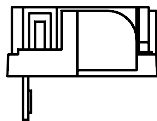

057H7071

DANFOSS
A57-564.11

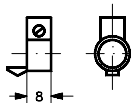

057H7072

DANFOSS
A57-562.11

H = 65,5
L = 520

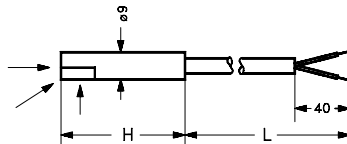

057H7087

DANFOSS
A57-566.10

Accessories

Service pack A - code no. 057H7022 - contains the following components:

Designation	Code no.	Comments
BHA 11/12	057H7020	Adapter
Photo unit	057H7087	Elongated housing and high light sensitivity
Flange	057H7071	As the old LD photo unit
Clamping ring	057H7072	

Please note that the BHO 64 is equipped with a hold - in relay for preheater applications.

Therefore, if you are using the adapter kit to replace a 57H, or old series BHO with the BHO 64, you will need to check if the boiler thermostat has been wired between terminals 7 & 9 in the old base. If it has this needs to be removed and rewired according to the yellow instruction sheet supplied with the adapter kit. Failure to do this will result in the boiler thermostat being bypassed and the boiler not shutting down.

Accessories

When servicing, the photo unit must also be replaced if reliable operation is to continue.

DANFOSS
A57-561.11

Top cover with 12 connections

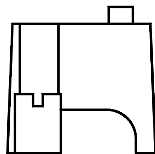
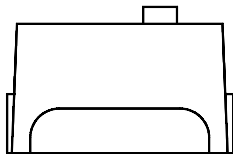

Adapter BHA 11/12

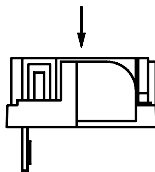
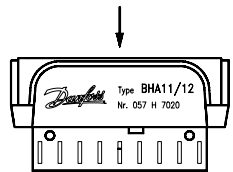

Base with 9 connections

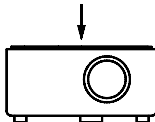
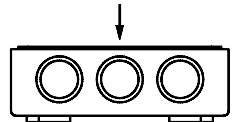

Adapter + BHO 64 have together the same height as BHO 11/12.

3. Ignition transformer/unit conversion

Contents

Introduction	Page 68
Conversion	52L -> EBI	Page 69
Dimensions	EBI	Page 71
Accessories	Page 72

Ignition transformer/unitconversion

The following tables give information on the conversion of ignition units.

The following old Danfoss ignition transformers are to be replaced: Type 52L.

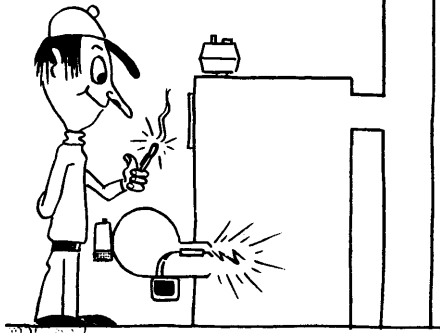

The overview is compiled as follows:

- Column 1 always gives the type of ignition transformers that are to be replaced.
- Column 2 gives the code numbers of the ignition transformers that are to be replaced.
- Column 4 gives the new electronic ignition units from Danfoss.
- Column 5 gives the corresponding code numbers.
- The last column gives the code numbers of the corresponding accessories.

Ignition transformers/units

52L			➡	EBI		
Type	Code no.	Comments/ accessories	➡	Type	Code no.	Comments/ accssories
52L	052L0000-03		➡	EBI	052F0030	+ 052F0102 + 052F0061
52L	052L0005		➡	EBI	052F0030	+ 052F0102 + 052F0061
52L	052L0007-09		➡	EBI	052F0030	+ 052F0102 + 052F0061
52L	052L0014-15		➡	EBI	052F0030	+ 052F0102 + 052F0061
52L	052L0017		➡	EBI	052F0030	+ 052F0102 + 052F0061
52L	052L0019-20		➡	EBI	052F0030	+ 052F0102 + 052F0061
52L	052L0023		➡	EBI	052F0030	+ 052F0102 + 052F0061
52L	052L0028		➡	EBI	052F0030	+ 052F0102 + 052F0061
52L	052L0034		➡	EBI	052F0030	+ 052F0102 + 052F0061
52L	052L0036-39		➡	EBI	052F0030	+ 052F0102 + 052F0061
52L	052L0041-42		➡	EBI	052F0030	+ 052F0102 + 052F0061
52L	052L0045-48		➡	EBI	052F0030	+ 052F0102 + 052F0061
52L	052L0050-56		➡	EBI	052F0030	+ 052F0102 + 052F0061
52L	052L0058-61		➡	EBI	052F0030	+ 052F0102 + 052F0061
52L	052L0063-64		➡	EBI	052F0030	+ 052F0102 + 052F0061
52L	052L0066-79		➡	EBI	052F0030	+ 052F0102 + 052F0061
52L	052L0082		➡	EBI	052F0030	+ 052F0102 + 052F0061
52L	052L0086-87		➡	EBI	052F0030	+ 052F0102 + 052F0061
52L	052L0089-93		➡	EBI	052F0030	+ 052F0102 + 052F0061
52L	052L0095-98		➡	EBI	052F0030	+ 052F0102 + 052F0061
52L	052L1033		➡	EBI	052F0030	+ 052F0102 + 052F0061
52L	052L1011		➡	EBI	052F0030	+ 052F0102 + 052F0061
52L	052L1050-51		➡	EBI	052F0030	+ 052F0102 + 052F0061
52L	052L1054-57		➡	EBI	052F0030	+ 052F0102 + 052F0061

Note: 052F0102 is a primary cable of 630 mm length.
For 052F0061 see page 72.

Ignition transformers/units

52L			➔	EBI		
Type	Code. no.	Comments/ accessories	➔	Type	Code no.	Comments/ accssories
52L	052L1075-76		➔	EBI	052F0030	+ 052F0102 + 052F0061
52L	052L1080		➔	EBI	052F0030	+ 052F0102 + 052F0061
52L	052L1085		➔	EBI	052F0030	+ 052F0102 + 052F0061
52L	052L0040		➔	EBI	052F0040 ²⁾	+ 052F0102 + 052F0061
52L	052L0049		➔	EBI	052F0040 ²⁾	+ 052F0102 + 052F0061
52L	052L0018		➔	EBI	052F0040 ²⁾	+ 052F0102 + 052F0061
52L	052L0026		➔	EBI	052F0040 ²⁾	+ 052F0102 + 052F0061
52L	052L0030		➔	EBI	052F0040 ²⁾	+ 052F0102 + 052F0061
52L	052L0065		➔	EBI	052F0040 ²⁾	+ 052F0102 + 052F006
52L	052L0088		➔	EBI	052F0040 ²⁾	+ 052F0102 + 052F0061
52L	052L1058		➔	EBI	052F0040 ²⁾	+ 052F0102 + 052F0061
52L	052L0006		➔			No replacement
52L	052L0013		➔			No replacement
52L	052L0016		➔			No replacement
52L	052L0021		➔			No replacement
52L	052L0044		➔			No replacement
52L	052L0062		➔			No replacement
52L	052L0099-1002		➔			No replacement
52L	052L1007-08		➔			No replacement
52L	052L1010		➔			No replacement
52L	052L1019		➔			No replacement
52L	052L1021-22		➔			No replacement
52L	052L0010		➔			No replacement
52L	052L0027		➔			No replacement

2) One pole ignition unit.

Dimensions- EBI

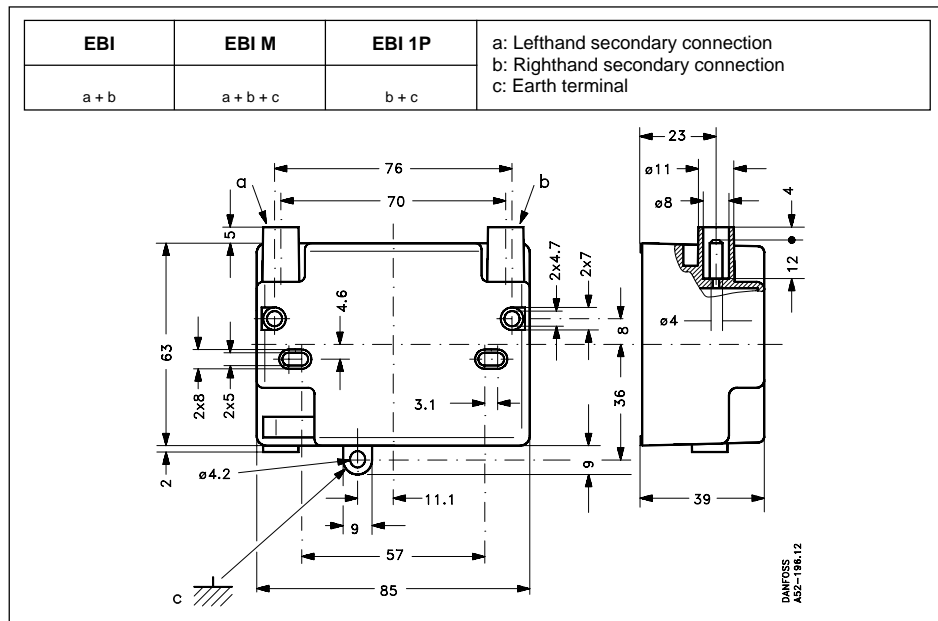

DANFOSS
AS2-196.12

Accessories

EBI service packs

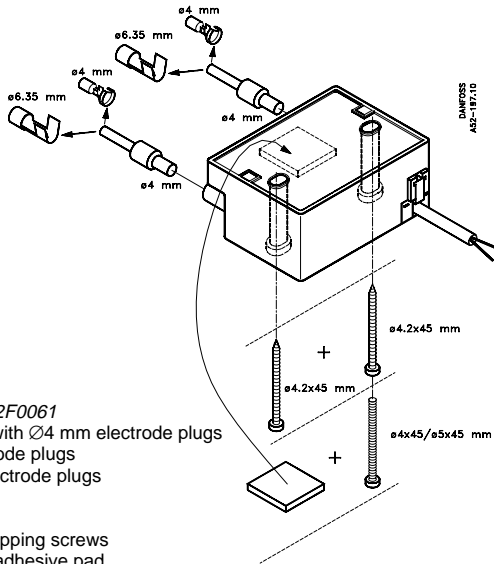

Accessory set 052F0061

- 2 ignition cables with Ø4 mm electrode plugs
- 2 x Ø4 mm electrode plugs
- 2 x Ø6.35 mm electrode plugs
- 2 x M4 screws
- 2 x M5 screws
- 2 x 4.2 mm self-tapping screws
- 1 x double-sided adhesive pad

The EBI accessory set 052F0061 is used, for example, when replacing a Danfoss type 52L ignition transformer or another make.

In addition to the high-voltage cables and electrode plugs, the accessory set also contains an assortment of screws. When fitting EBI only one screw and the double-sided adhesive pad are necessary. EBI can thus be used in most existing installations without it being necessary to drill new holes in the burner.

EBI accessory set 052F0063 contains an EBI (052F0030) with primary cable (052F0102) and accessory set 052F0061.

4. EH + ES series nozzles - conversion

Contents

Introduction	Page 74
Conversion data	Page 75
Ordering tables	Page 76 + 77
Marking	Page 78
Dimensions	Page 79
Nozzle capacities as function of pressure	Page 80
Nozzle capacities, net calorific values	Page 81



EH + ES series nozzles

Introduction

Danfoss has developed a series of oil nozzles types EH and ES for the optimum combustion of kerosene in domestic oil burners.

The standard oil nozzles type OD-CEN can also be used for the atomizing and dosing of kerosene - however, these oil nozzles have been calibrated and defined for the operation of standard fuel oil (3.4 cSt, density 840 kg/m³ and 10 bar).

Our existing oil nozzles e.g. 60°S and 80°H can directly be replaced by our new 60°ES - 80°EH. If standard oil nozzles OD-CEN are used in media with essentially changed specifications as e.g. kerosene, the tolerances of the oil

nozzle will be increased. With the new EH and ES nozzles the tolerance for throughput has been improved to $\pm 5\%$ for kerosene.

Reference Test Conditions

The EH + ES nozzles have been tested under the following reference conditions: Viscosity 1.65 sCt - density 790kg/m³, atomizing pressure 8 bar. Before leaving the production department, each nozzle is tested for:

- capacity
- spray angle
- atomizing characteristics and uniformity

Conversion

Nozzle Interchange Chart			
Hago H.SS	➡		Danfoss EH/H
Hago P, ES	➡		Danfoss ES/S
Delavan A	➡		Danfoss EH/H
Delevan B, W	➡		Danfoss ES/S
Monarch NS	➡		Danfoss EH/H
Monarch PLP, AR, R	➡		Danfoss ES/S
Steinen H, PH	➡		Danfoss EH/H
Steinen SS, Q	➡		Danfoss ES/S

Ordering tables – Type EH hollow spray pattern

Marking USgal/h	60°	80°	Nominal kg/h	l/h (rounded)	Filter mesh µm	Filter type
0.40		030H8304	1.20	1.50	45	Sinter
0.45	030H6306	030H8306	1.35	1.70	45	Sinter
0.50	030H6308	030H8308	1.50	1.90	75	Sinter
0.55	030H6310	030H8310	1.65	2.10	75	Sinter
0.60	030H6312	030H8312	1.80	2.25	75	Sinter
0.65	030H6314	030H8314	1.95	2.45	75	Sinter
0.75	030H6316	030H8316	2.25	2.85	75	Sinter
0.85	030H6318	030H8318	2.55	3.20	75	Sinter
1.00	030H6320	030H8320	3.00	3.80	75	Sinter
1.10	030H6322	030H8322	3.30	4.15	120	Sinter

Test specification (kg/h):

1.65 cSt
 790 kg/m³
 8 bar (115 psi)

$$l/h \sim \frac{\text{kg/h}}{0.79}$$

Ordering tables – Type ES solid spray pattern

Marking USgal/h	60°	80°	Nominal kg/h	l/h (rounded)	Filter mesh µm	Filter type
0.40	030F6304	030F8304	1.20	1.50	45	Sinter
0.45	030F6306	030F8306	1.35	1.70	45	Sinter
0.50	030F6308	030F8308	1.50	1.90	75	Sinter
0.55	030F6310	030F8310	1.65	2.10	75	Sinter
0.60	030F6312	030F8312	1.80	2.25	75	Sinter
0.65	030F6314	030F8314	1.95	2.45	75	Sinter
0.75	030F6316	030F8316	2.25	2.85	75	Sinter
0.85	030F6318	030F8318	2.55	3.20	75	Sinter
1.00	030F6320	030F8320	3.00	3.80	75	Sinter
1.10	030F6322	030F8322	3.30	4.15	120	Sinter

Test specification (kg/h):

1.65 cSt
790 kg/m³
8 bar (115 psi)

$$l/h \sim \frac{kg/h}{0.79}$$

Marking on EH + ES nozzle

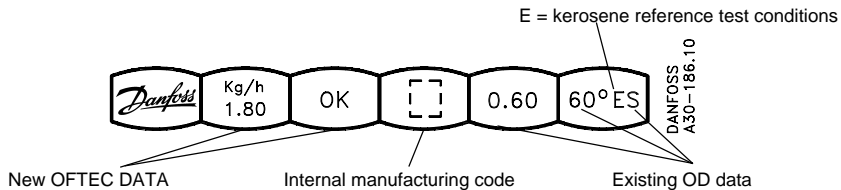

The nominal kg/h throughputs are at a test pressure of 8 bar with a permissible tolerance of $\pm 5\%$

Dimension

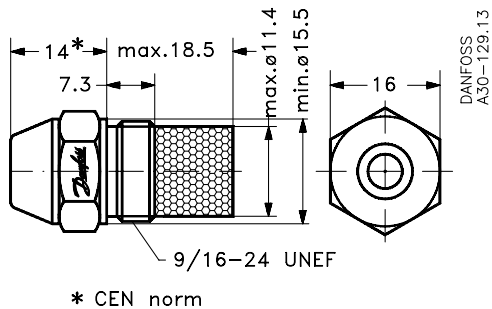

Nozzle capacities as function of pressure

Nozzle size	6 bar GPH	7 bar GPH	8 bar GPH	9 bar GPH	10 bar GPH
0.40	0.37	0.40	0.43	0.45	0.48
0.50	0.46	0.50	0.53	0.57	0.60
0.55	0.51	0.55	0.59	0.62	0.66
0.60	0.55	0.60	0.64	0.68	0.72
0.65	0.60	0.65	0.69	0.74	0.78
0.75	0.69	0.75	0.80	0.85	0.90
0.85	0.79	0.85	0.91	0.96	1.02
1.00	0.92	1.00	1.07	1.13	1.19
1.10	1.01	1.10	1.17	1.25	1.31
1.20	1.11	1.20	1.28	1.36	1.43
1.25	1.16	1.25	1.34	1.42	1.49
1.35	1.25	1.35	1.44	1.53	1.61
1.50	1.39	1.50	1.60	1.70	1.79
1.65	1.52	1.65	1.76	1.87	1.97
1.75	1.62	1.75	1.87	1.98	2.09

Nozzle Reference Test conditions

CEN Standard

Viscosity 3.40 cSt – density 840 kg/m³ atomizing pressure 10 bar.
Capacity kg/h.

OFTEC Reference Conditions

Viscosity 1.65 cSt – density 790 kg/m³ atomizing pressure 8 bar.
Capacity kg/h.

USgal Reference Conditions

Viscosity 3.40 cSt – density 820 kg/m³ atomizing pressure 7 bar.
Capacity USgal/h.

Note: when comparing nozzle capacity, kg/h or USgal – remember the definition point.

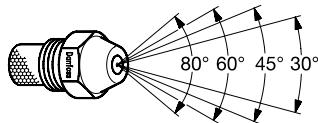

$$Q_2 \sim Q_1 \sqrt{\frac{P_2}{P_1}}$$

EH + ES series nozzles. Capacities, net calorific values** (rounded figs.)

Nozzle Size		6 bar		7 bar		8 bar		9 bar		10 bar	
kg/h**	USgal ***	kW	Btu's	kW	Btu's	kW	Btu's	kW	Btu's	kW	Btu's
1.20	0.40	12.50	42500	13.50	46000	14.45	49250	15.30	52250	16.15	55000
1.35	0.45	14.00	48000	15.20	51750	16.25	55500	17.25	58750	18.15	62000
1.50	0.50	15.65	53250	16.85	57500	18.00	61500	19.15	65250	20.15	68750
1.65	0.55	17.20	58500	18.50	63250	19.85	67750	21.00	71750	22.20	75750
1.80	0.60	18.75	64000	20.25	69000	21.65	73750	23.00	78250	24.20	82500
1.95	0.65	20.30	69250	22.20	74750	23.45	80000	24.85	84750	26.20	89500
2.25	0.75	23.45	80000	25.30	86250	27.00	92250	28.65	97750	30.25	103000
2.55	0.85	26.50	90500	28.65	97750	30.65	104500	32.50	111000	34.25	117000
3.00	1.00	31.25	106500	33.75	115000	36.00	123000	38.25	130500	40.30	137500
3.30	1.10	34.35	117250	37.00	126500	39.70	135250	42.00	143500	44.35	151250
3.60	1.20	37.50	128000	40.50	138250	43.30	147750	46.00	157000	48.40	165250
3.75	1.25	39.00	133000	42.20	145000	45.00	153500	47.85	163250	50.50	172500

* Nett value 43.30 MJ/kg

** Approx 12.00 kW/kg

*** Approx 123.000 Btu's/USgal/h

* For gross calorific values multiply by 1.069.

The above information gives a quick guide to nozzle output at different pump pressures. .

Remember to take into account boiler efficiency.

Example: Boiler rating 19.00 kW (65000 Btu's) Boiler eff. 85%, $19 \div 0.85 = 22.35$ kW

(76,268 Btu's) input req'd.

Nozzle selection: 1.80 kg/h (0.60 USgal/h) Nozzle at approx 8.54 bar

4. OD series oil nozzles - conversion

Contents

Introduction	Page 83
Range overview	Page 84
Conversion data	Page 85
Marking	Page 86
Dimensions	Page 87
Nozzle capacity / reference pressure	Page 88
Nozzle capacity / reference pressure CEN nozzles	Page 89



OD series oil nozzles - conversion

By far the most application requirements are met with only three basic types (S-H-B).

S = solid atomising pattern

H = hollow atomising pattern

B = semi-solid atomising pattern

The nozzles are available with four different spray angles:

30°, 45°, 60° and 80°.

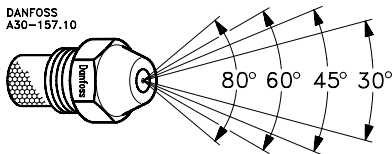

Danfoss oil nozzles cover capacities from 1.25 kg/h to 110 kg/h. (0.40 USgal/h to 35 USgal/h)

Note:

Danfoss oil nozzles are available with the following filters:

Capacity range
0.40 to 0.45 USgal/h
45 µm sinterbronze filter

Capacity range
0.50 to 1.00 USgal/h
75 µm sinterbronze filter

Capacity range
1.10 to 1.35 USgal/h
120 µm sinterbronze filter

Capacity range
1.50 to 11.00 USgal/h
140 µm monel mesh filter

Capacity range
12.0 USgal/h and above,
without filter

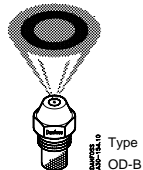
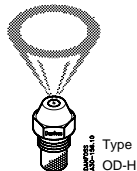
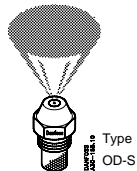

Danfoss oil nozzles, OD series

USgal/h	30°	45°	60°	80°	CENkg/h
0,40			S	S H	1,46
0,45			S H	S H	1,66
0,50	S H	S H	S H	S H	1,87
0,55	S H	S H	S H	S H	2,11
0,60	S H	S H	S H B	S H B	2,37
0,65	S H B	S H B	S H B	S H B	2,67
0,75	S H B	S H B	S H B	S H B	2,94
0,85	S H B	S H B	S H B	S H B	3,31
1,00	S H B	S H B	S H B	S H B	3,72
1,10	S H	S H	S H	S H	4,24
1,20	S H	S H	S H	S H	4,45
1,25	S H B	S H B	S H B	S H B	4,71
1,35	S H B	S H B	S H B	S H B	5,17
1,50	S H B	S H B	S H B	S H B	5,84
1,65	S H	S H	S H	S H	6,08
1,75	S H	S H	S H	S H	6,55
2,00	S H B	S H B	S H B	S H B	
2,25	S H B	S H B	S H B	S H B	
2,50	S H B	S H B	S H B	S H B	
2,75	S H B	S H B	S H B	S H B	
3,00	S H B	S H B	S H B	S H B	
3,50	S	S	S	S	

USgal/h	30°	45°	60°	80°	CENkg/h
3,75	B	B	B	B	
4,00		S	S	S	
4,50		S B	S B	S B	
5,00		S B	S B	S B	
5,50		S B	S B	S B	
6,00		S B	S B	S B	
6,50		B	B	B	
7,50		B	B	B	
8,50		B	B	B	
10,00		B	B	B	
11,00		B	B	B	
12,00		B	B	B	
13,50		B	B	B	
15,00		B	B	B	
17,00			B	B	
19,50			B	B	
22,00		B	B	B	
25,00			B	B	
28,00			B	B	
31,50		B	B	B	
35,00		B			

■ These oil nozzles are manufactured in accordance with European standard EN 293.

Danfoss oil nozzles type S, H and B can be used to replace the following nozzles of other makes:

Conversion to Danfoss oil nozzles		
Delavan A	➡	Danfoss H
Delavan B	➡	Danfoss S
Delavan W	➡	Danfoss B
Fluidics SF	➡	Danfoss S
Fluidics HF	➡	Danfoss H
Fluidics S	➡	Danfoss S
Fluidics H	➡	Danfoss H
Monarch PL	➡	Danfoss H/B
Monarch NS	➡	Danfoss H
Monarch PLP	➡	Danfoss B
Monarch AR	➡	Danfoss S
Monarch R	➡	Danfoss S
Hago B	➡	Danfoss S
Hago H	➡	Danfoss H
Hago SS	➡	Danfoss H/B
Hago P	➡	Danfoss S
Hago ES	➡	Danfoss S
Steinen PH	➡	Danfoss H/B
Steinen H	➡	Danfoss H
Steinen SS	➡	Danfoss B
Steinen Q	➡	Danfoss S
Steinen S	➡	Danfoss S

The values given are based on experience and should therefore only be considered as a guide.

Nozzle markings

Marking on CEN nozzles

The new CEN marking applies to the CEN definition point and nozzles are marked EN (European standard):

The nozzle capacity in kg/h is measured at an atomising pressure of 1000 kPa ($\times 10^{-2}$ bar) using a test oil with a viscosity of 3.4 mm²/s and a density of 840 kg/m³.

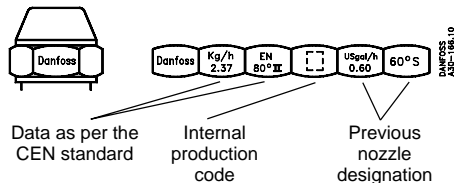

Marking on standard nozzles

The marking on standard nozzles gives the capacity in USgal/h, the spray pattern and spray angle at 700 kPa ($\times 10^{-2}$ bar) using a test oil with a viscosity of 3.4 mm²/s and a density of 820 kg/m³.

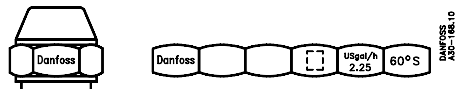

Dimensions

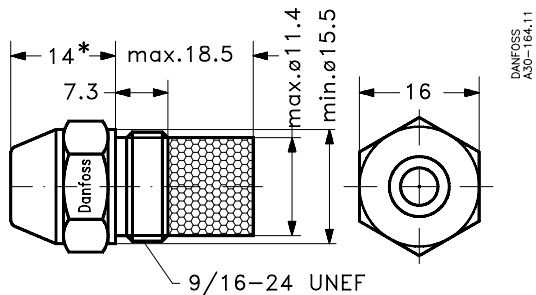

* CEN standard

Nozzle capacities

CEN

Nozzle capacities in kg/h as a function of the atomising pressure with an oil of viscosity 3.4 mm²/s and density 840 kg/m³.

Reference pressure

6 bar kg/h	7 bar kg/h	8 bar kg/h	10 bar kg/h	12 bar kg/h	14 bar kg/h
1,13	1,22	1,30	1,46	1,59	1,72
1,28	1,38	1,48	1,66	1,81	1,96
1,44	1,56	1,67	1,87	2,04	2,21
1,63	1,76	1,88	2,11	2,31	2,49
1,83	1,98	2,11	2,37	2,59	2,80
2,06	2,23	2,38	2,67	2,92	3,15
2,27	2,45	2,62	2,94	3,22	3,47
2,56	2,76	2,96	3,31	3,62	3,91
2,88	3,11	3,32	3,72	4,07	4,40
3,28	3,54	3,79	4,24	4,64	5,01
3,44	3,72	3,98	4,45	4,87	5,26
3,64	3,94	4,21	4,71	5,15	5,57
4,00	4,32	4,62	5,17	5,66	6,11
4,52	4,88	5,22	5,84	6,39	6,90
4,70	5,08	5,43	6,08	6,66	7,19
5,07	5,48	5,85	6,55	7,17	7,55

Nozzle capacities

Nozzle capacities in USgal/h as a function of the atomising pressure with an oil of viscosity 3.4 mm²/s and density 820 kg/m³.

Reference pressure					
6 bar GPH	7 bar GPH	8 bar GPH	10 bar GPH	12 bar GPH	14 bar GPH
0,37	0,40	0,43	0,48	0,52	0,56
0,42	0,45	0,48	0,54	0,59	0,64
0,46	0,50	0,53	0,60	0,65	0,71
0,51	0,55	0,59	0,66	0,72	0,78
0,55	0,60	0,64	0,72	0,78	0,85
0,60	0,65	0,69	0,78	0,85	0,92
0,69	0,75	0,80	0,90	0,98	1,06
0,79	0,85	0,91	1,02	1,11	1,20
0,92	1,00	1,07	1,19	1,31	1,41
1,01	1,10	1,17	1,31	1,44	1,55
1,11	1,20	1,28	1,43	1,57	1,70
1,16	1,25	1,34	1,49	1,64	1,77
1,25	1,35	1,44	1,61	1,77	1,97
1,39	1,50	1,60	1,79	1,96	2,12
1,52	1,65	1,76	1,97	2,16	2,33
1,62	1,75	1,87	2,09	2,29	2,47
1,85	2,00	2,14	2,39	2,62	2,83
2,08	2,25	2,41	2,69	2,95	3,18
2,31	2,50	2,67	2,99	3,27	3,54
2,54	2,75	2,92	3,29	3,60	3,89

Reference pressure

6 bar GPH	7 bar GPH	8 bar GPH	10 bar GPH	12 bar GPH	14 bar GPH
2,78	3,00	3,21	3,59	3,93	4,24
3,24	3,50	3,74	4,18	4,58	4,95
3,47	3,75	4,01	4,48	4,91	5,30
3,70	4,00	4,28	4,78	5,24	5,66
4,17	4,50	4,81	5,38	5,89	6,36
4,64	5,00	5,35	5,98	6,55	7,07
5,09	5,50	5,88	6,57	7,20	7,78
5,55	6,00	6,41	7,17	7,85	8,48
6,02	6,50	6,95	7,77	8,51	9,19
6,94	7,50	8,02	8,96	9,82	10,61
7,87	8,50	9,09	10,16	11,13	12,02
9,26	10,00	10,69	11,95	13,09	14,14
10,18	11,00	11,76	13,15	14,40	15,56
11,11	12,00	12,83	14,34	15,71	16,97
12,50	13,50	14,43	16,14	17,67	19,09
13,89	15,00	16,04	17,93	19,64	21,21
15,74	17,00	18,17	20,32	22,26	24,04
18,05	19,50	20,85	23,31	25,53	27,58
20,37	22,00	23,52	26,29	28,80	31,11
23,14	25,00	26,73	29,88	32,73	35,35
25,92	28,00	29,93	33,47	36,66	39,60
29,16	31,50	33,67	37,65	41,24	44,55

$$Q_2 \sim Q_1 \cdot \sqrt{\frac{P_2}{P_1}} \quad 1 \text{ USgal} \sim 3,785 \text{ l}$$

5. Oil preheater conversion

Contents

Introduction	Page 92
Danfoss standard	Types	Page 92
Dimensions	FPHB 5	Page 93
Dimensions	FPHB 10	Page 94

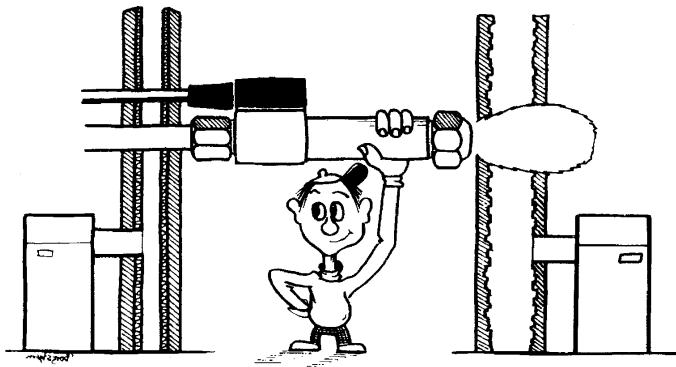

Preheater conversions

If the preheater needs replacing, consult the burner manufacturer. If a standard preheater is involved, it can also be purchased from an oil burner stockist or from Danfoss.

Danfoss standard types:

Type	Connection	Neck dia.	PTC	Code no.
FPHB 5	M8 x 1	18.5	1 x 70°	030N1201
FPHB 5	G 1/8	18.5	1 x 70°	030N1202
FPHB 5	G 1/8	18.2	1 x 70°	030N1218
FPHB 5	M8 x 1	18.2	1 x 70°	030N1219
FPHB 5	M16 x 1	18.5	1 x 120°	030N1223
FPHB 5	G 1/8	18.2	1 x 120°	030N1208
FPHB 10	G 1/8	18.5	2 x 120°	030N1220
FPHB 10	M8 x 1	18.2	2 x 120°	030N1224
FPHB 10	G 1/8	18.2	2 x 120°	030N1221

Dimensions – oil preheaters

FPHB 5

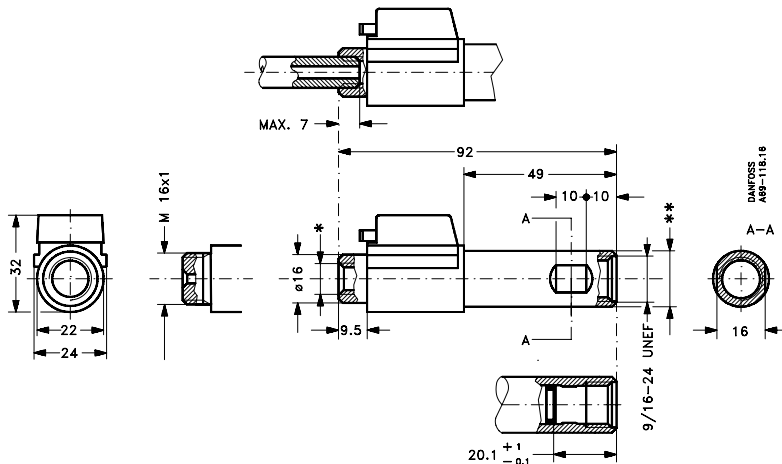

* Thread (see code no.)

** Neck diameter (see code no.)

Dimensions

FPHB 10

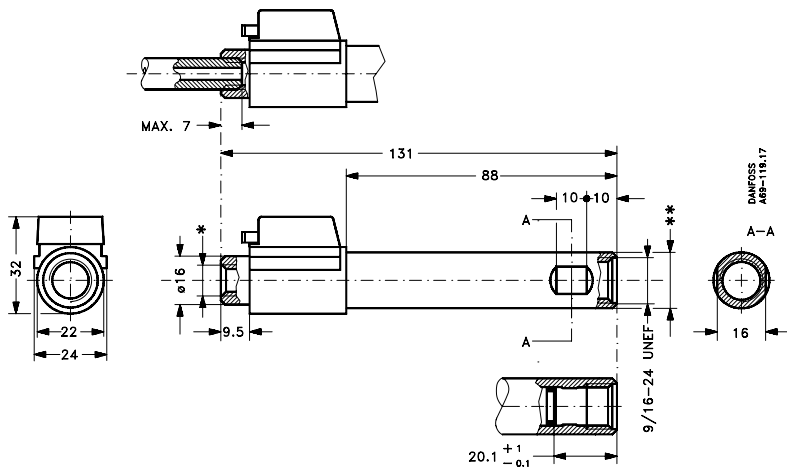

* Thread (see code no.)

** Neck diameter (see code no.)

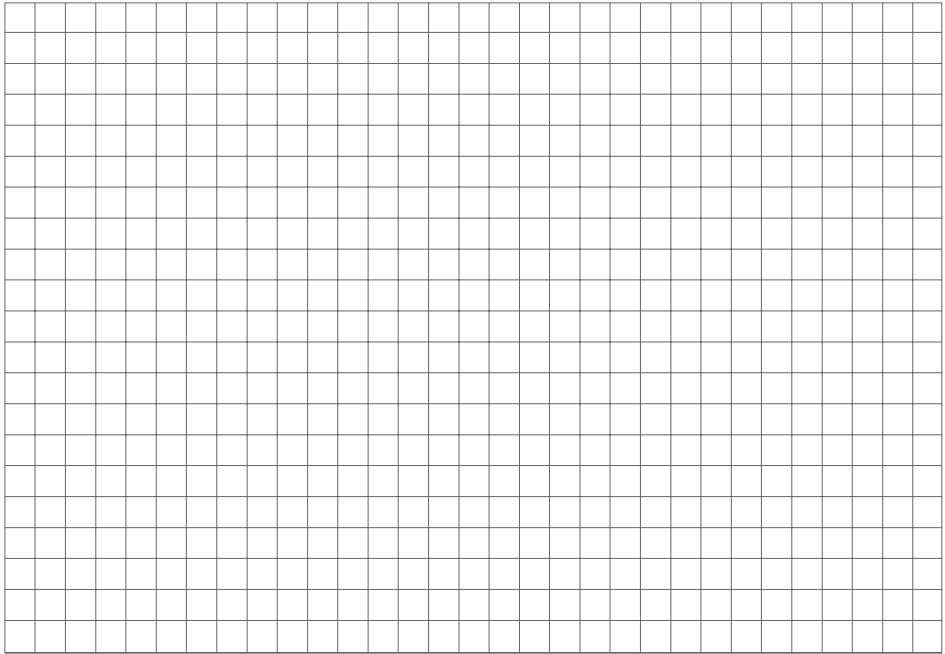

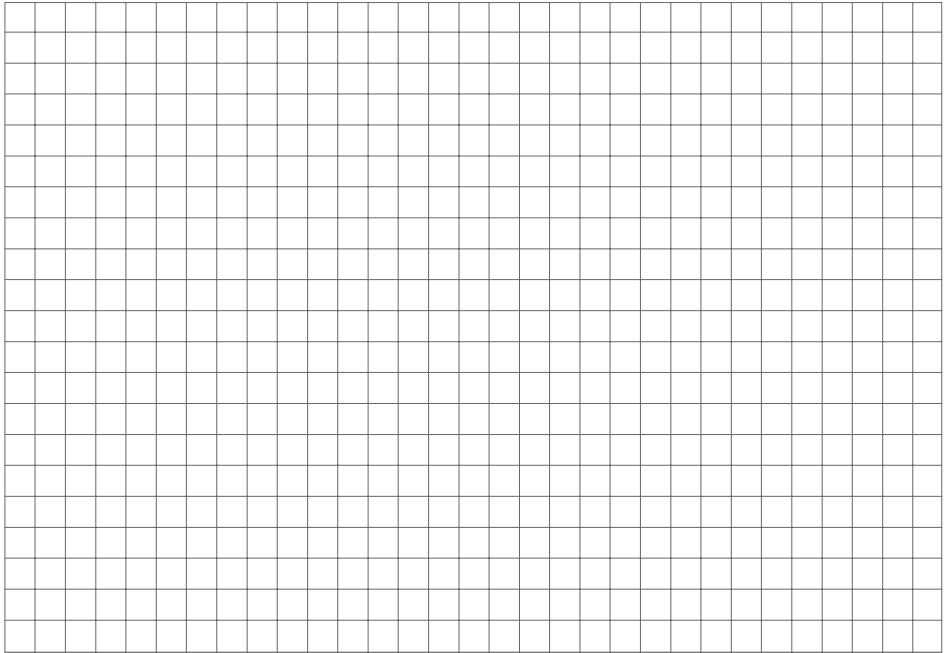

Danfoss can accept no responsibility for possible errors in catalogues, brochures and other printed material. Danfoss reserves the right to alter its products without notice. This also applies to products already on order provided that such alterations can be made without subsequential changes being necessary in specifications already agreed.
All trademarks in this material are property of the respective companies. Danfoss and the Danfoss logotype are trademarks of Danfoss A/S. All rights reserved.

The Danfoss logo is written in a red, cursive script font. It features a stylized 'D' and 'f' that are connected, with the 'o's and 's' following in a similar fluid, handwritten style.