

Termostaty blokowe

MBC 8000 and MBC 8100

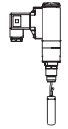

Podłączenie elektryczne/ Electrical connection/ Elektrischer Anschluss/ Raccordement électrique

- Uwaga:** Używaj jedynie wtyczek oryginalnych
Attention: Use only the accompanying plug, also when replacing
Achtung: Nur mitgelieferten Stecker verwenden, auch im Austausch
Attention: Utiliser exclusivement la prise fournie, même en cs de remplacement

Obciążenie styków
 Contact load
 Kontaktlast
 Charge de contact

AC 15: 0.5 A, 250 V
 DC 13: 12 W, 125 V

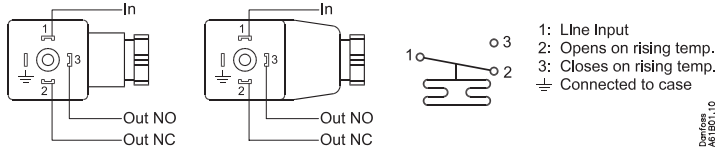

Danfoss
A17-593.12

Montaż Mounting and pressure connection Montage und Druckanschluß Installation et raccordement de pression

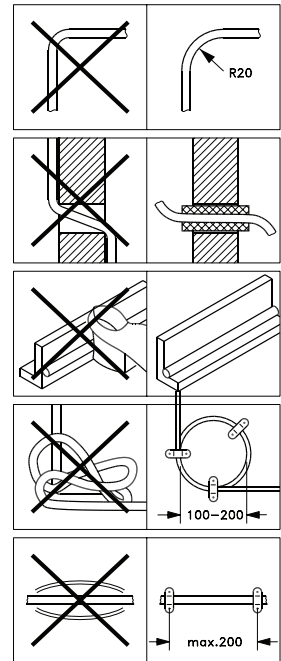
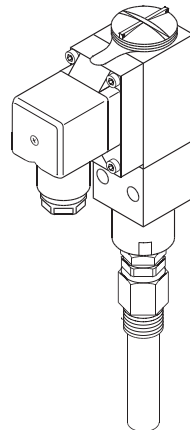
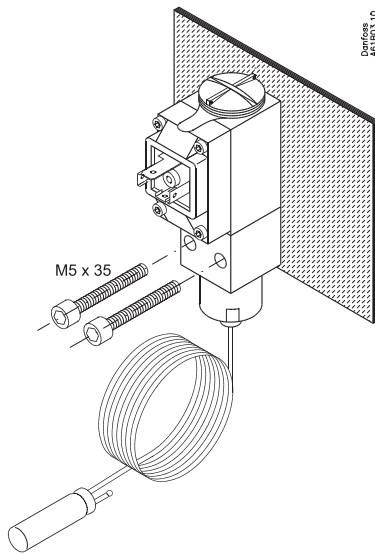

DANFOSS
A17-593.12

Uwagi/ Note/ Achtung/ Attention

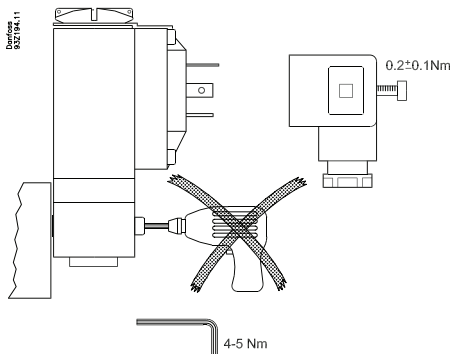

Wymiary/Dimensions/Masse/Dimensions

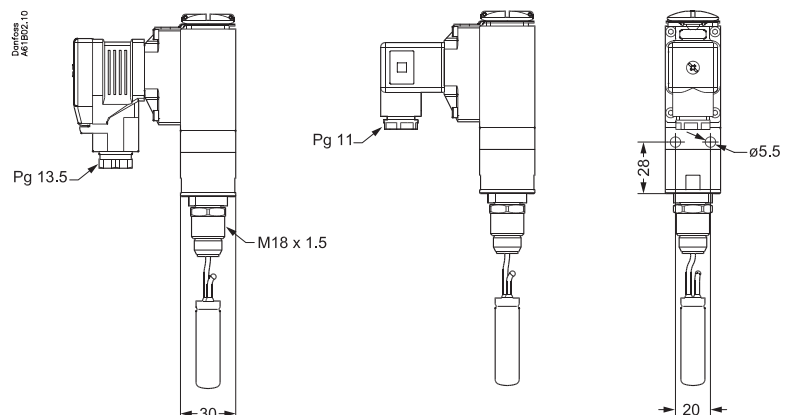

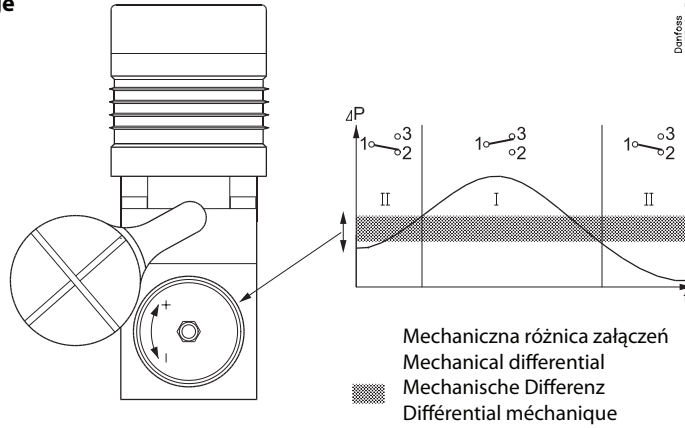
Nastawa/ Adjustment/ Justierung/ Ajustage

**Temperatura medium/otoczenia
 Operat. temperature
 Betriebstemperatur
 Température de service**

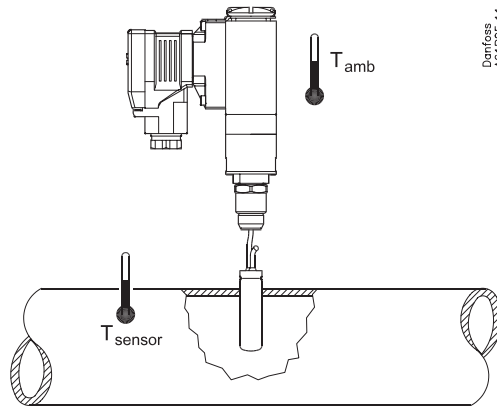
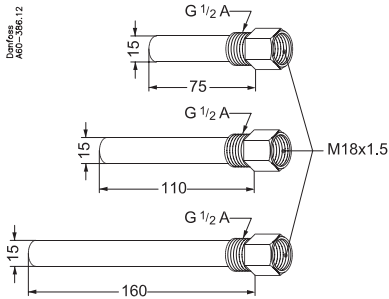
Zakres pomiarowy °C	Maks. temp. czujnika °C	Maks. temp. otoczenia °C
-10 → 30	80	-40 → 70
20 → 60	130	-40 → 70
50 → 100	200	-40 → 70
70 → 120	220	-40 → 70
60 → 150	250	-40 → 70
100 → 200	300	-40 → 70

**Akcesoria - kieszenie czujników/ Standard accessories/
 Standard Zubehör/ Accessoires standard**

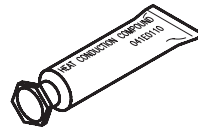
L (mm)	Ms	St.18/8
75	060L3262	060L3267
110	060L3271	060L3268
160	060L3263	060L3269

**Pasta termoprzewodząca (tubka 4.5cm³)
 Heat-conductive compound (4.5 cm³ tube)
 Wärmeleitpaste (Tube mit 4.5 cm³ Inhalt)
 Tube avec 4.5 cm³ du pâte conductrice.**

Nr katalogowy/ Code no. / Bestell-Nr./: 041E0114

Do wypełnienia kieszeni termostatu.

Compound for filling sensor pocket to improve heat transfer between pocket and sensor.

In die Fühlerhülse gefüllt, verbessert die Wärmeleitpaste die Wärmeübertragung zwischen Fühler und Hülsewand.

En remplir la poche à bulbe pour améliorer le transfert de chaleur.

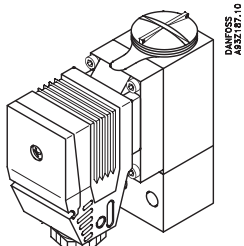
Urządzenia blokowe Danfoss/ Danfoss block components / Danfoss Block-Komponente / Danfoss gamme bloc

Presostaty
MBC 5000/5100

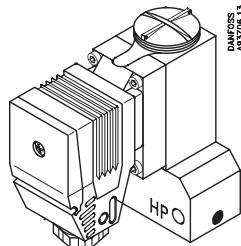

Presostaty różnicowe
MBC 5080/5180

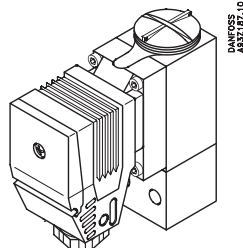

Przetworniki ciśnienia
MBS 5000/5100

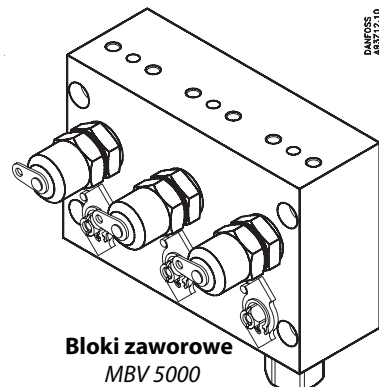

Bloki zaworowe
MBV 5000