

148R9511

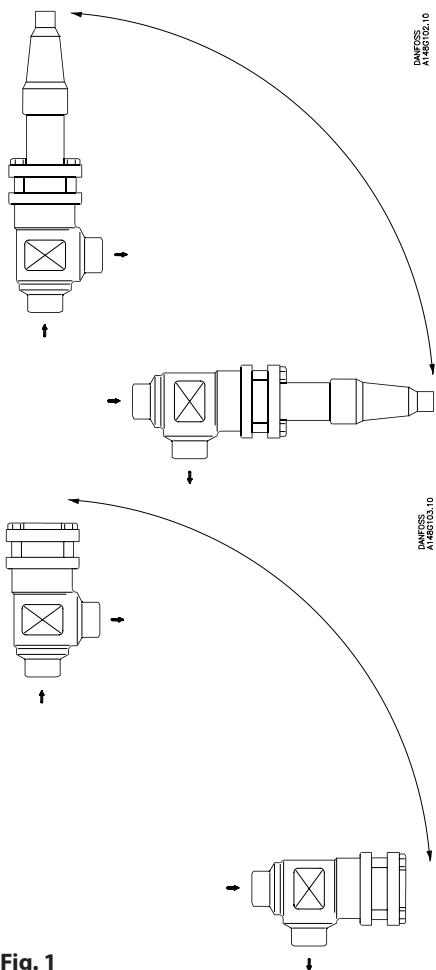

Fig. 1

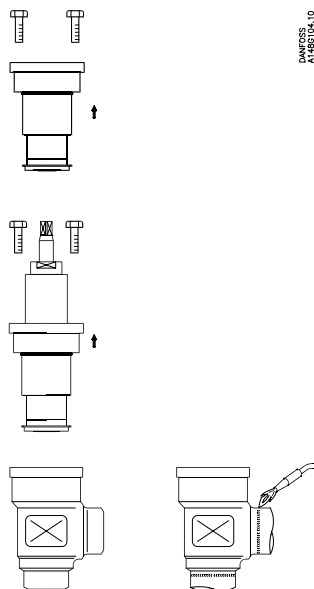

Fig. 2

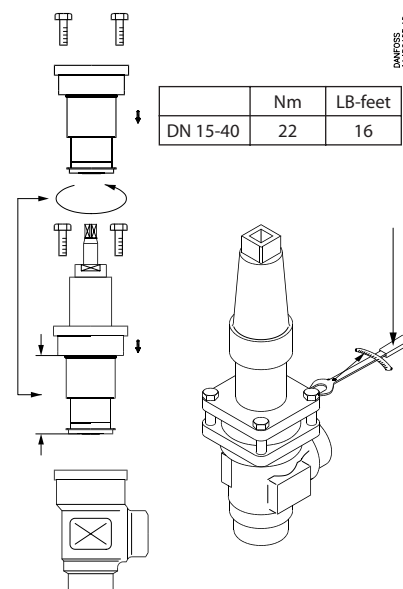

Fig. 3

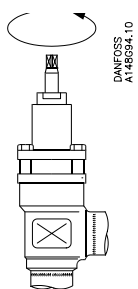

Fig. 4

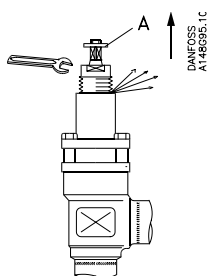

Fig. 5

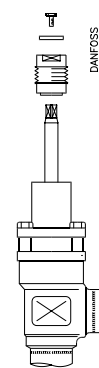

Fig. 6

	Nm	LB-feet
DN 15-25	50	37
DN 25-40	70	52
DN 50-65-80-100	60	45
DN 125-150-200	80	60

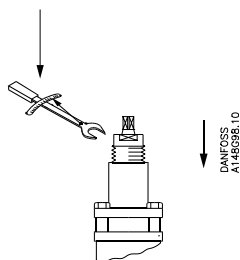

Fig. 7

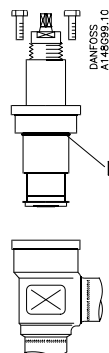

Fig. 8

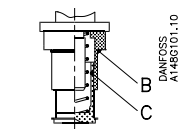
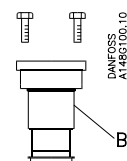

Fig. 9

148R9511

---

**Installation**

---

**Refrigerants**

Applicable to all common non-flammable refrigerants, including R717 and non-corrosive gases/liquids dependent on sealing material compatibility. Flammable hydrocarbons are not recommended. The valve is only recommended for use in closed circuits. For further information please contact Danfoss.

**Temperature range**

-50/+150°C (-58/+302°F)

**Pressure range**

The valves are designed for a max. working pressure of 25 bar g (363 psi g).

**Installation**

The valve must be installed with the spindle on top vertically upwards or in horizontal position (fig. 1). SCH valves should be opened by hand without the use of tools or other devices. The valve is designed to withstand a high internal pressure. However, the piping system should be designed to avoid liquid traps and reduce the risk of hydraulic pressure caused by thermal expansion. It must be ensured that the valve is protected from pressure transients like "liquid hammer" in the system.

**Flow direction**

Direct the flow towards the cone as indicated by an arrow on the valve housing (fig. 1).

**Welding**

The bonnet should be removed before welding (fig. 2) to prevent damage to the O-rings in the packing gland and between the valve body and bonnet, as well as the teflon gasket in the valve seat. Only materials and welding methods, compatible with the valve housing material, must be welded to the valve housing. The valve should be cleaned internally to remove welding debris on completion of welding and before the valve is reassembled.

Avoid welding debris and dirt in the threads of the housing and the bonnet.

Be careful not to damage the teflon cone ring.

The valve housing must be free from stresses (external loads) after installation.

Stop check valves must not be mounted in systems where the outlet side of the valve is open to atmosphere. The outlet side of the valve must always be connected to the system or properly capped off, for example with a welded-on end plate.

**Assembly**

Remove welding debris and any dirt from pipes and valve body before assembly. Check that the cone has been fully screwed

back towards the bonnet before it is replaced in the valve body (fig. 3).

Important for the SCH valves:

Full capacity is only obtained when the spindle is screwed outward, "into bonnet", i.e. counterclockwise (fig. 3).

**Tightening**

Tighten the bonnet with a torque wrench, to the values indicated in the table (fig. 3).

**Colours and identification**

The SCH and CHV valves are painted with a yellow primer in the factory. Precise identification of the valve is made via the ID ring at the top of the bonnet, as well as by the stamping on the valve body. The external surface of the valve housing must be prevented against corrosion with a suitable protective coating after installation and assembly.

Protection of the name plate when repainting the valve is recommended.

---

**Maintenance**

---

**Packing gland (only SCH)**

When performing service and maintenance, replace the complete packing gland only, which is available as a spare part. As a general rule, the packing gland must not be removed if there is internal pressure in the valve. However, if the following precautionary measures are taken, the packing gland can be removed with the valve still under pressure:

**Backseating (fig. 4)**

To backseat the valve, turn the spindle counterclockwise until the valve is fully open.

**Pressure equalization (fig. 5)**

In some cases, pressure forms behind the packing gland. Hence, a handwheel or a large washer (pos. A) should be fastened on top of the spindle while the pressure is equalized. The pressure can be equalized by slowly screwing out the gland.

**Removal of packing gland (fig. 6)**

Handwheel and packing gland can now be removed.

**Dismantling the valve (fig. 8)**

Do not remove the bonnet while the valve is still under pressure.

- Check that the O-ring (pos. B) has not been damaged.
- Check that the spindle is free of scratches and impact marks.
- If the teflon cone ring has been damaged, the whole cone assembly must be replaced.

**Replacement of the cone (fig. 9)**

O-ring (pos. C) prevents the cone from falling out. Pull the cone clear of the bonnet. Be careful not to loose the spring. Remove dirt, if any. Mount O-ring (pos. C) on cone. Mount spring and cone in bonnet.

**Assembly**

Remove dirt, if any, from pipes and housing before assembly. Important for the SCH valves: Full capacity is only obtained when the spindle is screwed outward, "into the bonnet", i.e. counterclockwise (fig. 3). Use a torque wrench to tighten the bonnet (fig. 3).

**Tightening**

Tighten the bonnet with a torque wrench, to the values indicated in the table (fig. 3). Tighten the packing gland with a torque wrench, to the values indicated in the table (fig. 7).

Use only original Danfoss parts, including packing glands, O-rings and gaskets for replacement. Materials of new parts are certified for the relevant refrigerant.

In cases of doubt, please contact Danfoss. Danfoss accepts no responsibility for errors and omissions. Danfoss Industrial Refrigeration reserves the right to make changes to products and specifications without prior notice.

**DECLARATION OF CONFORMITY**  
The Pressure Equipment Directive 97/23/EC



**Name and Address of Manufacturer within the European Community**

Danfoss Industrial Refrigeration A/S  
Stormosevej 10  
PO Box 60  
DK-8361 Hasselager  
Denmark

**Declaration**

We hereby declare that below-mentioned equipment are classified for Fluid Group I (all refrigerants (toxic, non-toxic, flammable and non-flammable)), and that all are covered by Article 3, paragraph 3.

For further details / restrictions – see Installation Instruction

**Description of Pressure Equipment**

Refrigerant stop valve, with straight or angled bonnet arrangement

**Type SCH/CHV**

Nominal bore	<b>DN ≤ 25 mm</b> (1 in.)
--------------	---------------------------

**References of other Technical Standards and Specifications used**

prEN 12284      DIN 3158  
AD-Merkblätter

**Authorised Person for the Manufacturer within the European Community**

**Name:** Morten Steen Hansen      **Title:** Production Manager

**Signature:** Morten Steen Hansen      **Date:** 31/01/2002

148B9718 - rev. 0

**DECLARATION OF CONFORMITY**  
The Pressure Equipment Directive 97/23/EC



**Name and Address of Manufacturer within the European Community**

Danfoss Industrial Refrigeration A/S  
Stormosevej 10  
PO Box 60  
DK-8361 Hasselager  
Denmark

**Description of Pressure Equipment**

Refrigerant stop/check valve, with straight or angled arrangement

**Type SCH/CHV**

Nominal bore	<b>DN 32-40 mm</b> (1 $\frac{1}{4}$ - 1 $\frac{1}{2}$ in.)	
Classified for	<b>Fluid Group I</b> (all refrigerants (toxic, nontoxic, flammable and nonflammable)). For further details / restrictions - see Installation Instruction.	
Temperature range maximum allowable working pressure	SCH/CHV	-50°C/+150°C (-58°F/+302°F)
	SCH/CHV	<b>25 bar</b>

**Conformity and Assessment Procedure Followed**

Category	<b>I</b>
Module	<b>A</b>

**References of Harmonised Standards used**

EN 10222-4

**References of other Technical Standards and Specifications used**

prEN 12284      DIN 3158  
AD-Merkblätter

**Authorised Person for the Manufacturer within the European Community**

**Name:** Morten Steen Hansen

**Title:** Production Manager

**Signature:**

Morten Steen Hansen

**Date:** 31/01/2002

148B9719 - rev. 0