

DCR

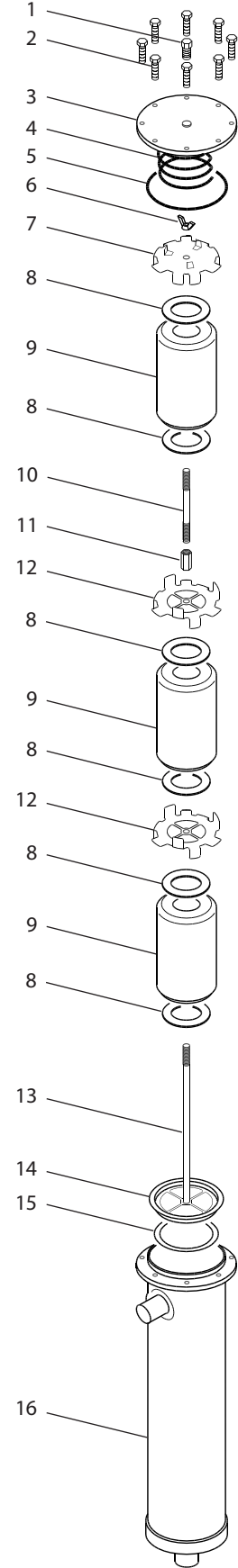

Pos.	Description
1	Plug 1/4 in. NPT
2	Top cover bolts M8 x 35, class 10.9 or M12 x 40, class 8.8 (high pressure)
3	Top cover
4	Spring
5	Top cover gasket Ø121.8 x Ø113.6 x 0.8mm
6	Wing nut M10 (torque max. 3 Nm)
7	Top plate
8	Felt gasket Ø95.5 x Ø45.5 x 2 mm
9	Solid core
10	Extension rod
11	Extension nut
12	Intermediate plate
13	Distance rod
14	Bottom plate / strainer
15	Felt gasket Ø95.5 x Ø78 x 2 mm
16	Filter drier shell

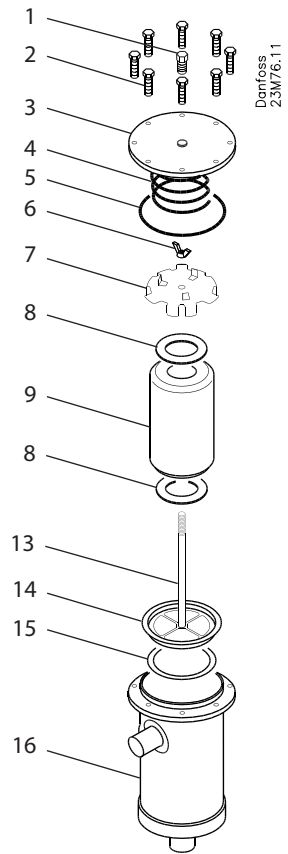

Installation

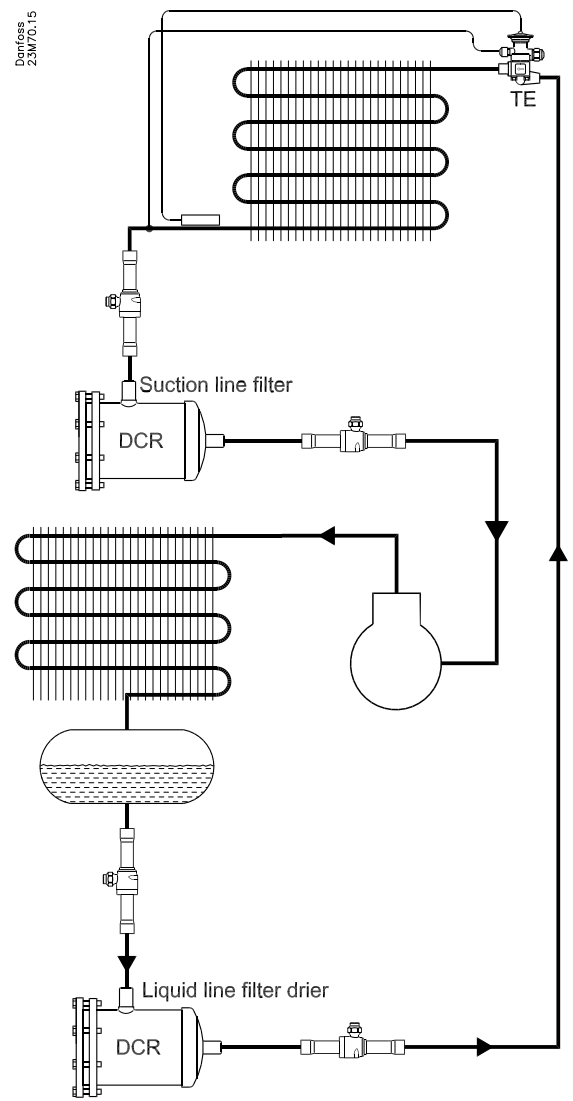

Type	L minimum		PS (MWP)	
	[mm]	[in.]	P _e [bar]	PSI
DCR 048 - Normal pressure	170	7	35	500
DCR 096 - Normal pressure	310	13	35	500
DCR 144 - Normal pressure	310	13	35	500
DCR 192 - Normal pressure	310	13	28	400
DCR 048 - High pressure	170	7	46	667
DCR 096 - High pressure	310	13	46	667

Note:
Max working pressure PS(MWP) shall not be less than the pressure outlined in sect 8.2 of ANSI/ASHRAE 15 for the refrigerant used in the system. After charging, the system shall be marked with the refrigerant and oil used.



Temperature range:
-40°C → 70°C (-40°F → 160°F)

Soldering

Danfoss
2.3M71.11

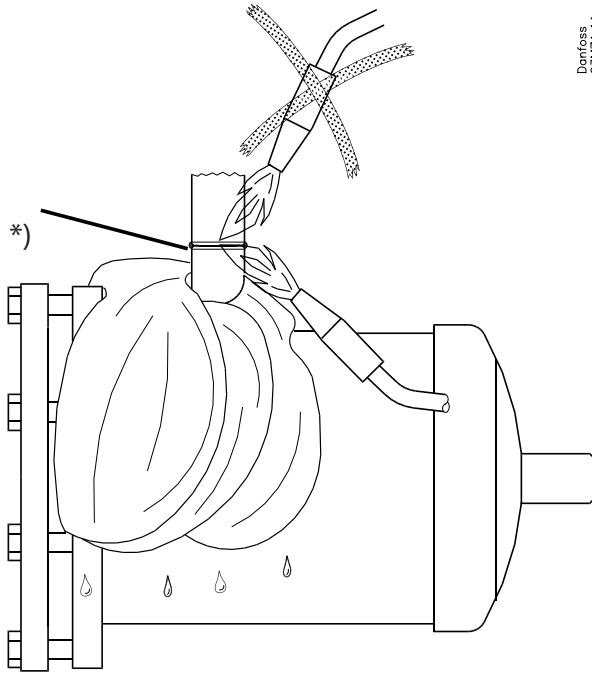

*)

Connector type	Soldering material
Cu	Sil-fos 15
Fe	Silver-flo 55 + Easy-flow flux

Gasket

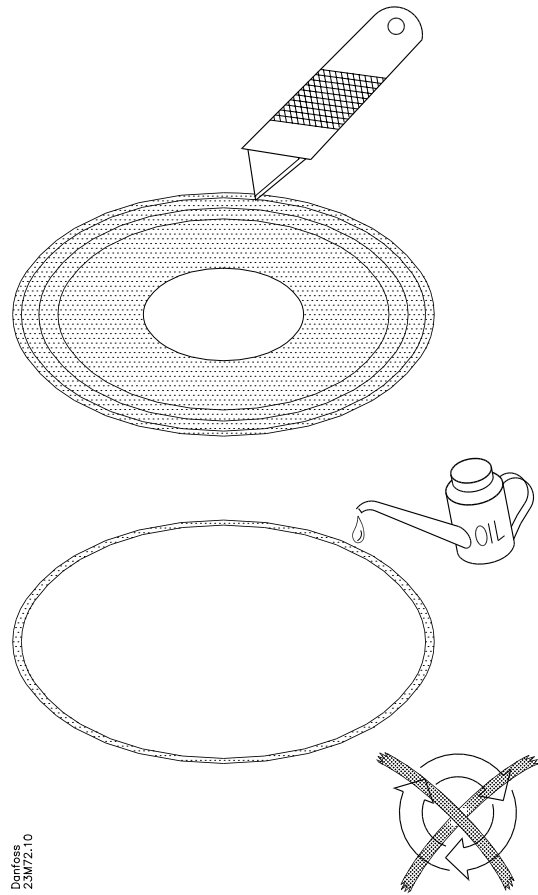

Danfoss
2.3M72.10

Do not reuse
the gasket

How to tighten the bolts

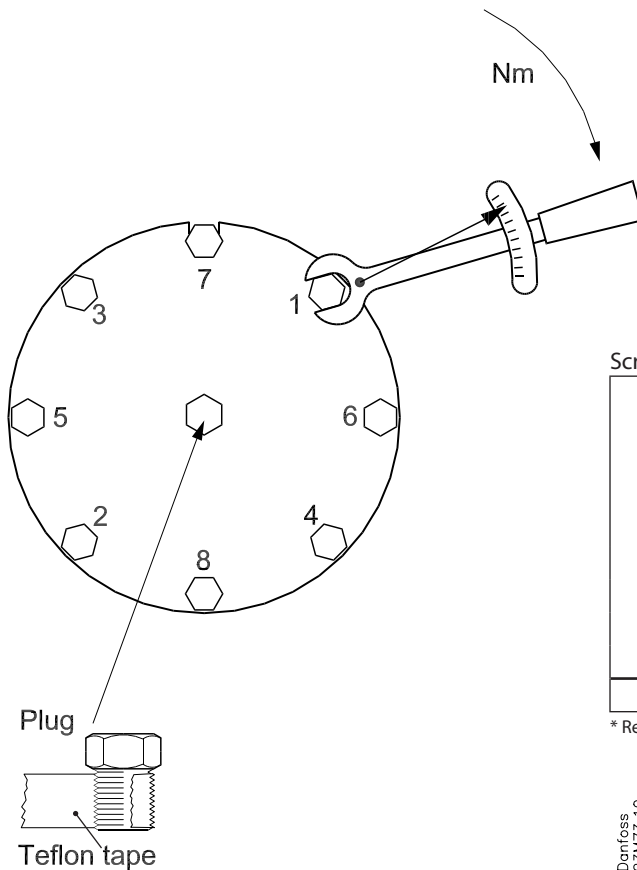

Screw type:

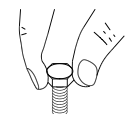
M8 + M12	Step 1	 Fingertighten all bolts
	Step 2	3 Nm
	Step 3	10 Nm
	Step 4	20 Nm
	Step 5*	35 Nm
M12	Step 6*	42 Nm

* Repeat until complete tightness has been reached.

Danfoss
2.3M73.10