

027R9523

027R9523

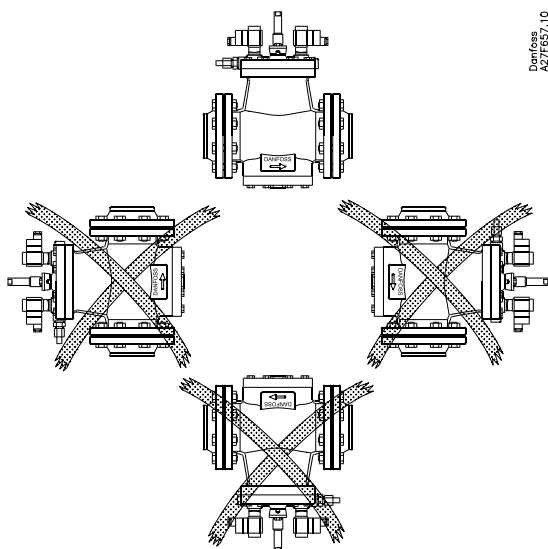

Danfoss  
A27F657.10

Fig. 1

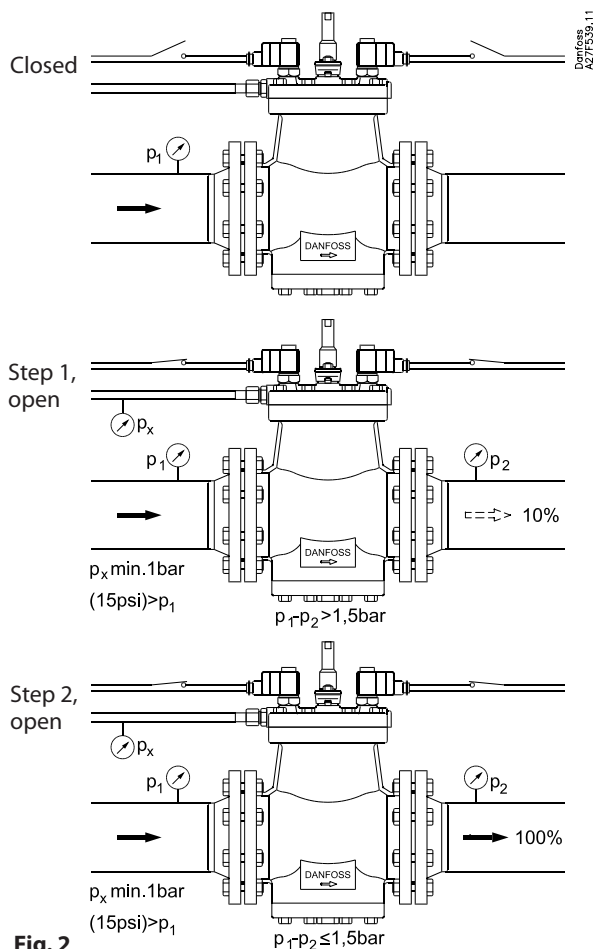
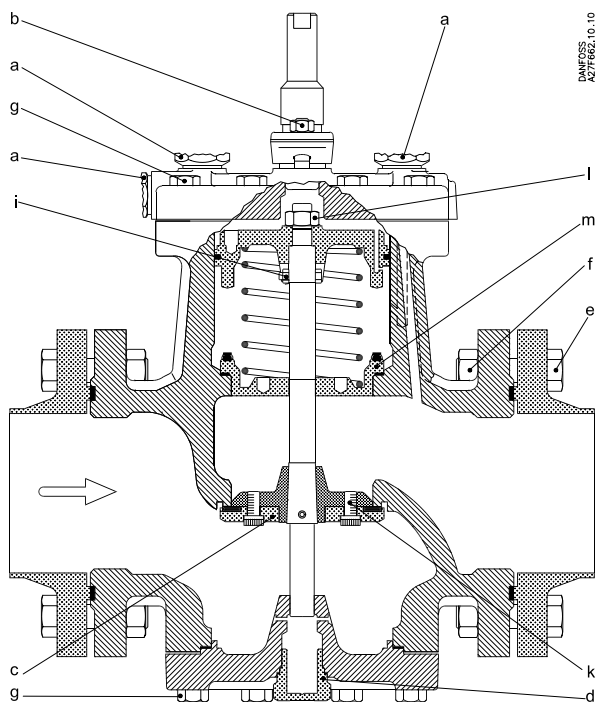

Fig. 2



Danfoss  
A27F652.10.10

Fig. 3

Pos. item	Torque		
	Nm	kpm	lbf-ft
	10	1	7.4
Tightening Torque in Nm			
	80	100	125
a	50		
b	65		
c	25		
d	140		
e	80	80	125
f	105	135	200
g	75	80	125
i	9		
k	25	40	60
l	45	60	90
m	150	220	310

Table 1

IP 67 (IEC 529/DIN 40050)

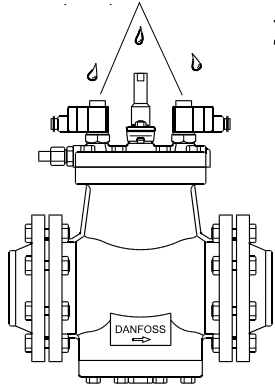

140 > TB(°C) ≥ 10 ⇒ PB(bar) = 28  
 -10 > TB(°C) > 50 ⇒ PB(bar) = 21

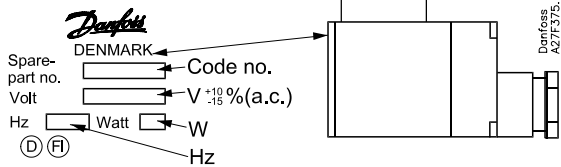



Fig. 4

Danfoss  
A27F371.11

10/12 W a.c. - 15% 

t<sub>min.</sub> -40°C  
(-40°F)

t<sub>max.</sub> 80°C  
(175°F)

Max. opening diff. pressure  
(MOPD) 21bar (300psig)

20 W d.c. ± 10% 

t<sub>min.</sub> -40°C  
(-40°F)

t<sub>max.</sub> 50°C  
(120°F)

Max. opening diff. pressure  
(MOPD) 14bar (200psig)

Fig. 5

$p_x > p_1 + 2\text{bar}$

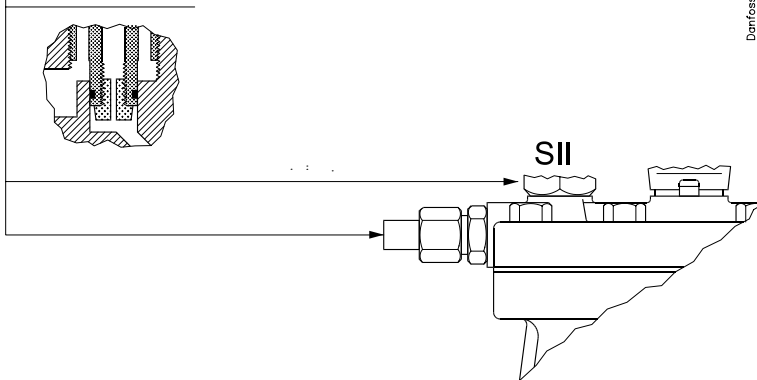

Fig. 6

---

**Installation**

---

**Refrigerants**

Applicable to all common non-flammable refrigerants, including R717 and non-corrosive gases/liquids dependent on sealing material compatibility.

Flammable hydrocarbons are not recommended. The valve is only recommended for use in closed circuits. For further information please contact Danfoss.

**Temperature range**

PML: -60/+120°C (-76/+248°F)

**Pressure range (fig. 5)**

PML: The valves are designed for a max. working pressure of 28 bar g (406 psi g).

**Technical data**

The PML can be used in suction, liquid, hot-gas and liquid/vapour lines. The PML regulates the flow of the medium by on/off function, depending on the control impulse from the screwed-on pilot valves.

The PML has three connections for pilot valves: two in series, marked "S I" and "S II", and one in parallel with these two, marked "P", see fig. 3.

**Installation**

Flange set for the PML is delivered separately. The valve must be installed with the arrow in the direction of the flow and the top cover upwards (fig. 1). The top cover can be rotated 4 X 90° in relation to the valve body.

The valve is fitted with a spindle for manual opening.

If an external pilot valve is used, the pilot line must be connected to the upper side of the main line so that any dirt and oil from the plant will not find its way into the pilot line.

The valve is designed to withstand a high internal pressure. However, the piping system should be designed to avoid liquid traps and reduce the risk of hydraulic pressure caused by thermal expansion. It must be ensured that the valve is protected from pressure transients like "liquid hammer" in the system.

**Welding**

If using welding flanges, only materials and welding methods, compatible with the flange material must be welded to the flanges. The flanges should be cleaned internally to remove welding debris on completion of welding and before the valve is inserted.

The valve housing and flanges must be free from stresses (external loads) after installation.

PML valves must not be mounted in systems where the outlet side of the valve is open to atmosphere. The outlet side of

the valve must always be connected to the system or properly capped off, for example with a welded-on end plate.

**Colours and identification**

The PML valves are Zinc-Chromated in the factory. If further corrosion protection is required, the valves can be painted. Precise identification of the valve is made via the ID plate on the top cover. The external surface of the valve housing must be prevented against corrosion with a suitable protective coating after installation and assembly.

Protection of the ID plate when repainting the valve is recommended.

---

**Maintenance**

---

**Service**

The PML valves are easy to dismantle and most of its parts are replaceable. When the bottom cover is removed, the strainer can be taken out for cleaning.

Do not open the valve while the valve is still under pressure.

- Check that the O-ring has not been damaged.
- Check that the spindle is free of scratches and impact marks.
- If the teflon ring has been damaged, the parts must be replaced.

**Assembly**

Remove any dirt from the body before the valve is assembled. Check that all channels in the valve are not blocked with particles or similar.

**Tightening**

*Tightening torques*

See fig. 3 and table 1.

Use only original Danfoss parts, including packing glands, O-rings and gaskets for replacement. Materials of new parts are certified for the relevant refrigerant.

In cases of doubt, please contact Danfoss. Danfoss accepts no responsibility for errors and omissions. Danfoss Industrial Refrigeration reserves the right to make changes to products and specifications without prior notice.









