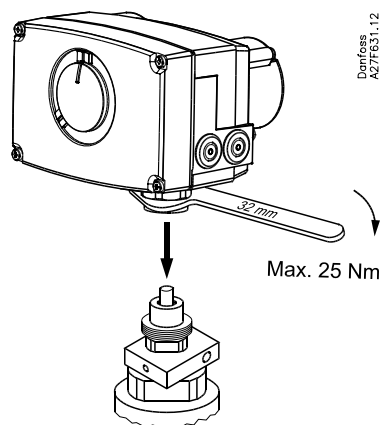
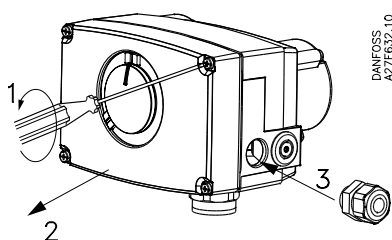


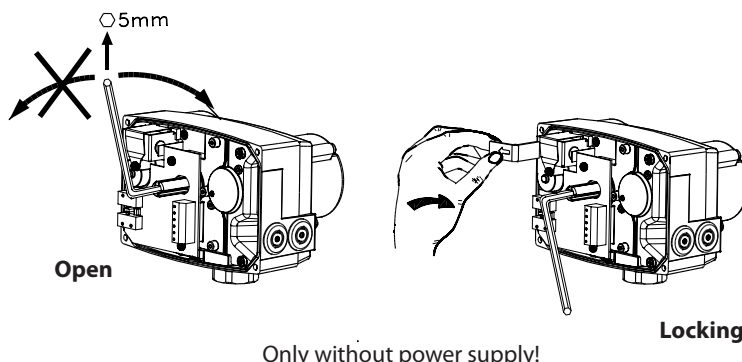
**Fig. 1** M = motor spindle



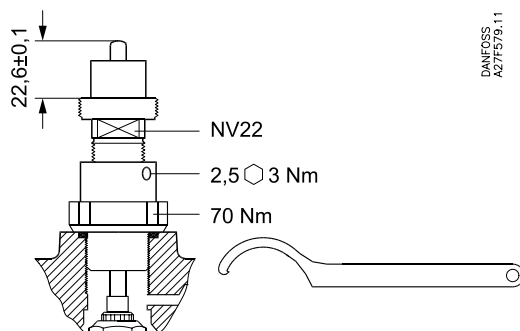
**Fig. 2**



**Fig. 3** M = motor spindle

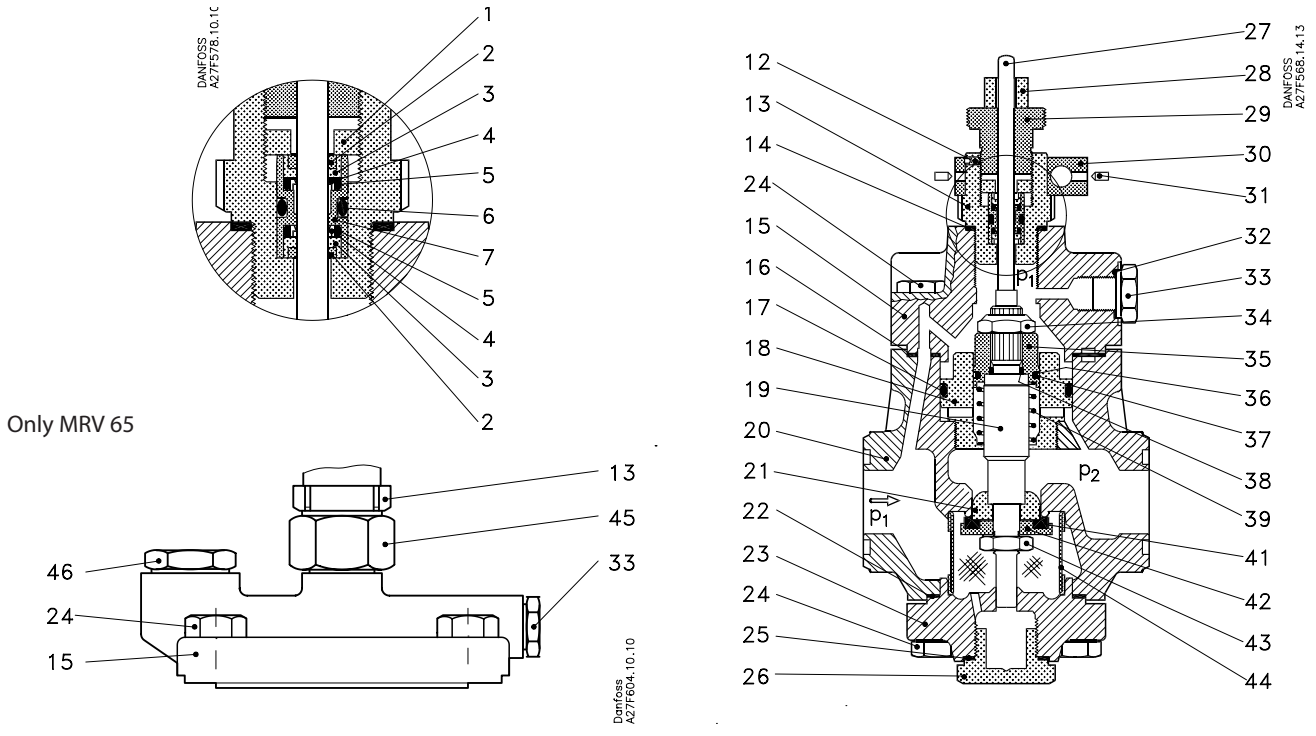


**Fig. 4**



**Fig. 5**

## Push pin seal assembly



### ENGLISH

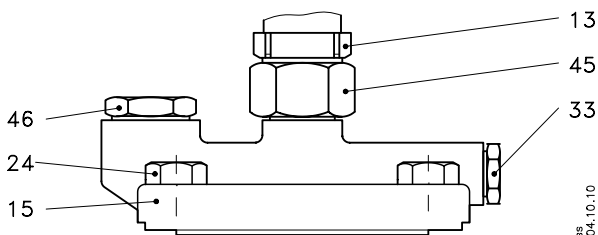
- |                   |  |                         |
|-------------------|--|-------------------------|
| 1 Nut             | 19 Spindle                             | 32 Gasket               |
| 2 Dirt seal       | 20 Valve body                          | 33 Blanking plug        |
| 3 Bush            | 21 Regulating cone                     | 34 Nut                  |
| 4 Seal            | 22 Gasket                              | 35 Balancing piston     |
| 5 O-ring          | 23 Bottom cover                        | 36 Piston seal          |
| 6 O-ring          | 24 Bolt                                | 37 O-ring               |
| 7 Insert          | 25 Gasket                              | 38 O-ring               |
| 12 Locking screw  | 26 Bottom plug                         | 39 Spring               |
| 13 Nipple         | 27 Push pin                            | 41 Sealing disc         |
| 14 Gasket         | 28 Distance piece<br>(MRV 5 - 25 only) | 42 Valve plate          |
| 15 Top cover      | 29 Adjusting screw                     | 43 Nut                  |
| 16 Gasket         | 30 Heating element housing             | 44 Filter               |
| 17 O-ring         | 31 Locking screw                       | 45 Nipple (MRV 65 only) |
| 18 Cylinder liner |  | 46 Blanking plug        |

SMV/SMVE motor spindle speed at:

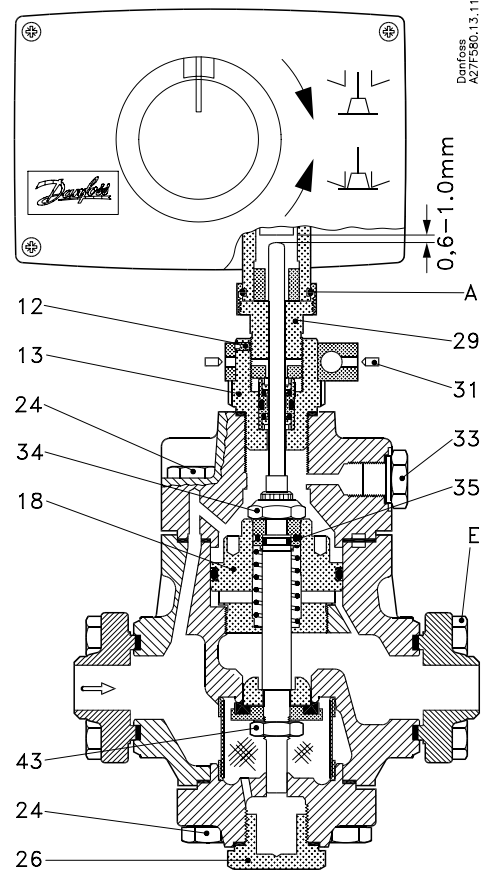
50 Hz	3 s/mm
60 Hz	2.4 s/mm



Only MRV 65



Danfoss  
A27F604.10.10



Danfoss  
A27F560.13.11

Pos.	MRV 5 - 25				MRV 32				MRV 40				MRV 50				MRV 65			
	T	M	N	L	T	M	N	L	T	M	N	L	T	M	N	L	T	M	N	L
A	-	25	32	-	-	25	32	-	-	25	32	-	-	25	32	-	-	25	32	-
E	M 12 × 1.75	60	18	45	M 12 × 1.75	60	18	45	M 12 × 1.75	60	18	45	M 14 × 2	80	21	65	M 14 × 2	80	21	70
12	M 5	3	X	5	M 5	3	X	5	M 5	3	X	5	M 5	3	X	5	M 5	3	X	5
13	-	70	S	-	-	70	S	-	-	70	S	-	-	70	S	-	-	70	S	-
18	M 39 × 1.5	60	S	-	M 48 × 1.5	100	S	-	M 52 × 2	100	S	-	M 64 × 2	100	S	-	M 80 × 2	100	S	-
24	M 10 × 1.5	45	16	30	M 10 × 1.5	45	16	30	M 12 × 1.75	60	18	35	M 12 × 1.75	60	18	35	M 14 × 2	80	21	40
26	M 24 × 1.5	50	36	-	M 24 × 1.5	50	36	-	M 24 × 1.5	50	36	-	M 24 × 1.5	50	36	-	M 24 × 1.5	50	36	-
29	-	-	22	-	-	-	22	-	-	-	22	-	-	-	22	-	-	-	22	-
31	-	-	X	-	-	-	X	-	-	-	X	-	-	-	X	-	-	-	X	-
33	R ½	30	19	12	R ½	30	19	12	R ½	30	19	12	R ½	30	19	12	R ½	30	19	12
34	M 10 × 1.5	30	16	-	M 10 × 1.5	30	16	-	M 10 × 1.5	30	16	-	M 10 × 1.5	30	16	-	M 10 × 1.5	30	16	-
35	-	-	18	-	-	-	18	-	-	-	18	-	-	-	18	-	-	-	18	-
43	M 10 × 1.5	30	16	-	M 12 × 1.75	40	18	-	M 12 × 1.75	40	18	-	M 16 × 2	50	24	-	M 16 × 2	60	24	-
45	-	-	-	-	-	-	-	-	-	-	-	-	-	-	-	-	M 24 × 1.5	70	36	-

**ENGLISH**

- T Thread
- M Torque
- N Span of jaws, width across flats
- L Length of screw
- S Special key needed
- X Hexagonal key needed

## Installation

### Refrigerants

Applicable to all common non-flammable refrigerants, including R717 and non-corrosive gases/liquids dependent on sealing material compatibility. Flammable hydrocarbons are not recommended. The valve is only recommended for use in closed circuits. For further information please contact Danfoss.

### Temperature range

MRV:  $-60/+120^{\circ}\text{C}$  ( $-76/+248^{\circ}\text{F}$ )

### Pressure range

MRV: The valves are designed for a max. working pressure of 28 bar g (406 psi g).

### Design

MRV is a balanced valve which is held closed by a built-in spring.

With counter-flow, the valve is only capable of closing tight against a differential pressure less than the force of the return spring (approx. 3 bar).

Depending on the control signal requirement, a SMV or SMVE motor can be fitted to open the valve by acting on the valve push pin.

#### Valve cone

A logarithmic regulating cone provides optimum regulation accuracy.

#### Push pin seal assembly

Replaceable seal assembly in stainless steel with double sealing system.

#### Valve sizes

MRV is available in sizes from MRV 5 ( $k_v$ : 1.6 m<sup>3</sup>/h) to MRV 65 ( $k_v$ : 72 m<sup>3</sup>/h).

### Installation

The valve is fitted with a spindle for manual opening.

If an external pilot valve is used, the pilot line must be connected to the upper side of the main line so that any dirt and oil from the plant will not find its way into the pilot line.

The valve is designed to withstand a high internal pressure. However, the piping system should be designed to avoid liquid traps and reduce the risk of hydraulic pressure caused by thermal expansion. It must be ensured that the valve is protected from pressure transients like "liquid hammer" in the system.

MRV + SMV/SMVE can be installed in vertical or horizontal pipelines (with motor upwards when mounted horizontally – see fig. 1).

The top cover of the MRV can be turned 90° in any direction without any influence on the valve function.

The valve can be fitted with an AKS 45 electronic position indicator (available as an accessory).

### Function

The MRV can be used in suction, liquid, hot-gas and liquid/vapour lines. The MRV regulates the flow of the medium by modulation or on/off function, depending on the control impulse to the motor.

MRV incorporates a balancing piston (35) that ensures the valve operates with low opening and closing forces. Therefore the differential pressure across the valve has minimal effect on the valve opening and closing forces.

Inlet pressure  $P_1$  acting on the underside of the regulating cone (21) is led via internal channels in the valve body to the top of the balancing piston. The pressure on the underside of the regulating cone is thus equalised.

In the same way, outlet pressure  $P_2$ , which acts on the top of the regulating cone, is led via an internal channel to the underside of the balancing piston.

The balancing piston operates in a cylinder liner (18) and is fitted with a sealing ring for tight sealing.

MRV is fitted with a spring (39) that closes the valve when the push pin (27) is not activated. The SMV/SMVE motor is fitted with a return spring that forces the motor spindle closed when no voltage is being applied to the motor. This means that the MRV valve closes automatically when, for example, the power fails. (This is a standard function of the SMV/SMVE motor, but can be disconnected, by using the angle bracket accessory, fig. 4).

#### NOTE!

Power supply **must be** isolated before opening valve manually!

An AKS 45 position indicator can be fitted instead of the MRV bottom plug (26). An output signal (4 - 20 mA) of the exact position of the valve cone can be obtained during operation, together with digital on/off signals for fully open and fully closed valve.

A heating element can be fitted on the MRV valve neck to keep the pressure pin free of ice (for use with media temperatures under 0°C).

MRV has a pressure gauge connection (33) for registering valve inlet pressure  $P_1$ .

#### Welding

If using welding flanges, only materials and welding methods, compatible with the flange material must be welded to the flanges. The flanges should be cleaned internally to remove welding debris on completion of welding and before the valve is inserted.

The valve housing and flanges must be free from stresses (external loads) after installation.

MRV valves must not be mounted in systems where the outlet side of the valve is open to atmosphere. The outlet side of the valve must always be connected to the system or properly capped off, for example with a welded-on end plate.

### Delivery

MRV valves are supplied with flange gaskets and flange bolts. Flanges, motor, and spindle heater if required, are supplied separately.

### Installation

The MRV valve must be installed with the arrow in the direction of flow. When installing an MRV, refrigerant must not be allowed to escape and dirt must not be allowed to enter the valve. If the temperature of the medium flowing through the valve is less than 0°C a spindle heater must be used.

#### Assembled motorised valve

The motorised valve must not be installed with the push pin (27) vertically downwards and the SMV/SMVE motor actuator spindle vertically upwards (fig. 1). Secure the SMV/SMVE motor on the neck of the MEV/MRV motorised valve with a union nut (32 mm A/F) (max. 25 Nm) using the adjusting screw (22 mm A/F) to provide counter torque (fig. 2).

#### NOTE!

Distance piece must be used for MEV/MRV 5 - 25 (fig. 2).

When the valve is closed there is 0.6 - 1.0 mm clearance between the SMV/SMVE motor actuator spindle and the MRV motorised valve push pin.

MRV valves are kept closed by a built-in spring. In a refrigerant reverse flow condition, the valve will remain tightly closed at differential pressures below the force of the return spring (approx. 3 bar).

### Manual operation

*SMV/SMVE can be operated manually as follows (NB! Power supply must be isolated before opening valve manually!):*

1. Isolate the SMV/SMVE power supply.
2. Loosen the four screws in the cover (fig. 3).
3. SMV/SMVE can be operated manually using a 5 mm hex. key and a strip of cardboard (supplied with SMV/SMVE on delivery) (fig. 4). Insert the key in the plastic spindle and turn it clockwise to open the valve. The valve position can then be locked by inserting the cardboard strip as shown in fig. 4.
4. When the cardboard strip is removed the spring return system will always automatically close the valve, provided the SMV/SMVE remains isolated from the power supply.

### Insulation

If a spindle heater is fitted it must be outside the insulation material.

**Service**

The MRV valves are easy to dismantle and most of its parts are replaceable. Do not open the valve while the valve is still under pressure.

1. Check that the O-ring has not been damaged.
2. Check that the spindle is free of scratches and impact marks.
3. If the teflon ring has been damaged, the parts must be replaced.

A precise service schedule cannot be given for the valve as service intervals will depend on operating conditions, i.e. how often the valve operates and the amount of impurities and dirt the system carries.

**Push Pin seal assembly**

The MRV valve seal assembly can only be replaced as a unit; it cannot be dismantled for repair. The spindle seal of a new MRV valve is adjusted at the factory and locked with two locking screws (pos. 12) to ensure the distance between the MRV push pin and the SMV/SMVE motor thrust pad is correct. This adjustment must be made when the seal is replaced.

*Replacement of push pin seal assembly (fig. 5)*

1. Relieve pressure on the MRV valve and evacuate refrigerant in accordance with authority requirements.
2. Remove the SMV/SMVE motor, and spindle heater if fitted.
3. Remove the seal by loosening the seal housing (pos. 13) with the special key from the seal spare parts set.
4. Fit a new seal assembly and tighten the housing (pos. 13) with a torque of 70 Nm. This corresponds to turning it 15 degrees = 1/24 of a turn after finger tightening.

*Adjustment of push pin assembly*

The push pin must be adjusted so that the height in relation to the seal housing (pos. 13) is correct.

1. Loosen the locking screws (pos. 12) and turn the adjusting screw (pos. 29) until the height of the push pin (pos. 27) is 22.6 +/-0.1 mm above the adjusting screw.
2. Lock the adjusting screw by tightening the locking screws with a torque of 3 Nm.

*Replacement of complete MRV-spindle assembly*

When servicing the valve the complete spindle assembly must be replaced, i.e. the spindle (pos. 19), balancing piston (pos. 35), piston O-ring (pos. 36), O-ring (pos. 37), and valve plate (pos. 42).

1. Relieve pressure on the MRV valve and evacuate refrigerant in accordance with authority requirements.
2. Remove the SMV/SMVE motor, and spindle heater if fitted.
3. Screw off the MRV valve top and bottom covers.

4. Remove the top nut on the spindle (pos. 34) using the balancing piston (pos. 35, 18 mm A/F) to provide counter torque. See Note.
5. Withdraw the spindle from the bottom of the valve.
6. Take the balancing piston (pos. 35) including piston seal out of the top of the valve.
7. Lubricate the valve internal cylinder with refrigeration machine oil.
8. Insert the new spindle into the housing, from below.
9. Insert the new balancing piston (pos. 35) incl. piston seal in the valve, from above (be careful not to damage the seals during assembly as these must be provide a complete seal during operation).
10. Assemble remaining valve parts in the reverse order to dismantling.

**Note!** Do not use the nut (pos. 43) to provide counter torque. The valve can only be expected to close tightly if all parts that comprise a "complete spindle assembly" are replaced at the same time, and the degree of tightening of the nut (pos. 43) holding the valve plate (pos. 42) against the regulating cone (pos. 21) is not changed.

If it becomes necessary, the cylinder liner with O-ring (pos. 18 and 17) for the balancing piston can be changed, but this is not considered to be a part of normal servicing. Special tools have to be made for cylinder replacement. The old cylinder must be screwed out and the new one tightened using the correct torque (MRV 5-25: 60 Nm, MRV 32-65: 100 Nm).

Use only original Danfoss parts, including packing glands, O-rings and gaskets for replacement. Materials of new parts are certified for the relevant refrigerant.

In cases of doubt, please contact Danfoss. Danfoss accepts no responsibility for errors and omissions. Danfoss Industrial Refrigeration reserves the right to make changes to products and specifications without prior notice.



**DECLARATION OF CONFORMITY**  
The Pressure Equipment Directive 97/23/EC



**Name and Address of Manufacturer within the European Community**

Danfoss Industrial Refrigeration A/S  
Stormosevej 10  
PO Box 60  
DK-8361 Hasselager  
Denmark

**Declaration**

We hereby declare that below-mentioned equipment are classified for Fluid Group I (all refrigerants (toxic, non-toxic, flammable and non-flammable)), and that all are covered by Article 3, paragraph 3.

For further details / restrictions – see Installation Instruction

**Description of Pressure Equipment**

Refrigerant main regulating valves  
Type **PM, PMC, PMFH, PMFL, MRV, MEV**

Nominal bore **DN ≤ 25 mm.** (1 in)

**References of other Technical Standards and Specifications used**

prEN 12284      DIN 3158  
EN 1563      AD-Merkblätter

**Authorised Person for the Manufacturer within the European Community**

**Name:** Morten Steen Hansen      **Title:** Production Manager

**Signature:**       **Date:** 16/01/2002

148B9715 - rev. 1

