

067F9505

PB = 42 bar / MWP = 600 psig
 P_{test} = max. 46.5 bar (670 psig)

Inlet filter (optional)



1/2 in.	067L1281
5/8 in.	067L1282
7/8 in.	067L1283
1 1/8 in.	067L1284

Flow direction:

Normal: A → B

Reverse: B → A

Q_{nom.} A → B [kW] = 100%

Q_{nom.} B → A [kW] = 80%

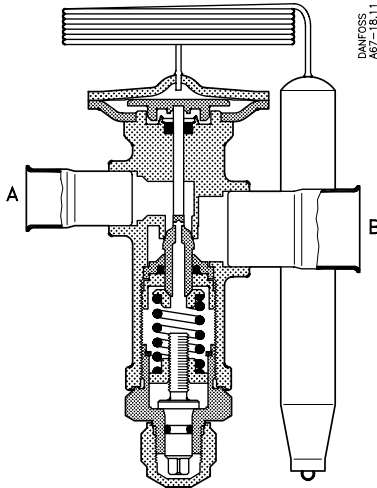

Adjustable setting

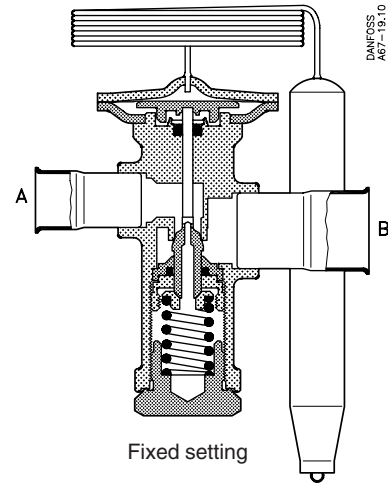

Fixed setting

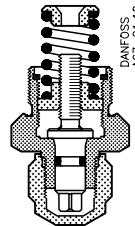

Setting kit (optional)

R 22

TRE 10: 8 → 10 TR / 28 → 35 kW

TRE 20: 10 → 20 TR / 35 → 70 kW

TRE 10	067L1295	T = 30 Nm (22ft-lbf)
TRE 20	067L1296	T = 46 Nm (34ft-lbf)

Spring not included

067F9505

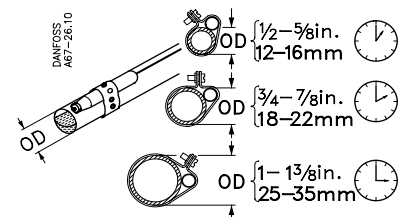
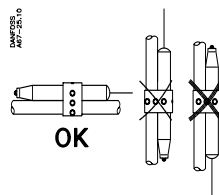
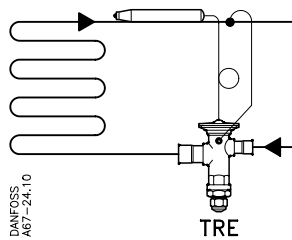
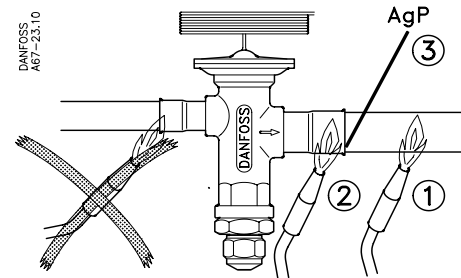
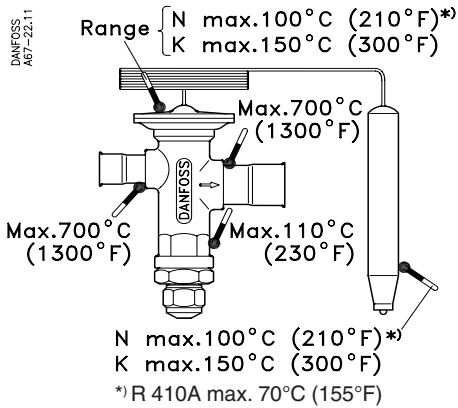

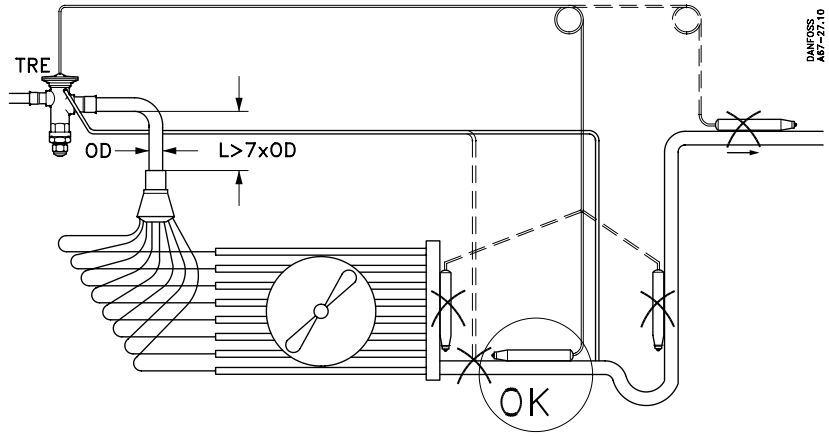
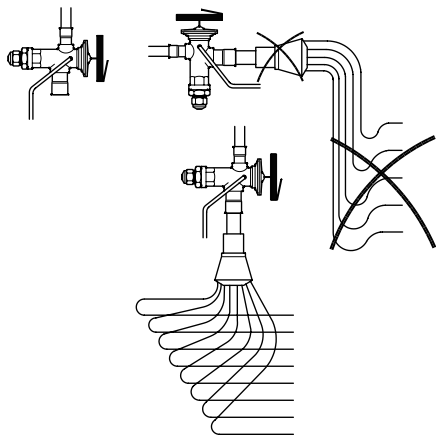

DANFOSS
AG7-27.10

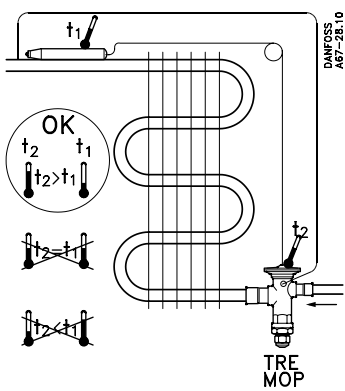

DANFOSS
AG7-28.10

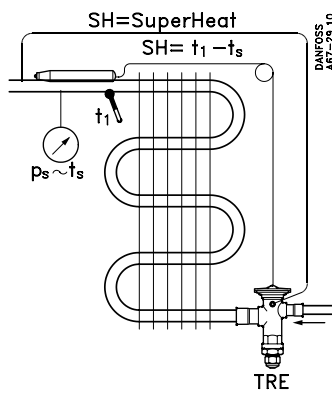

DANFOSS
AG7-29.10

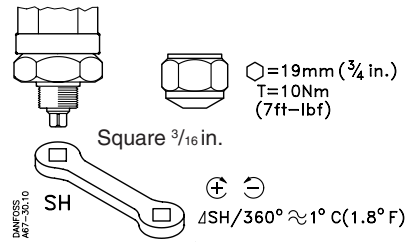

DANFOSS
AG7-31.12

