

## PMFH

027R9522

027R9522

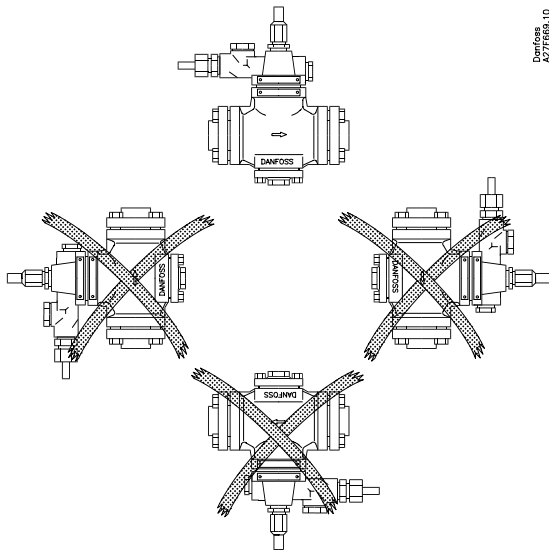

1

Danfoss  
A27F69.10

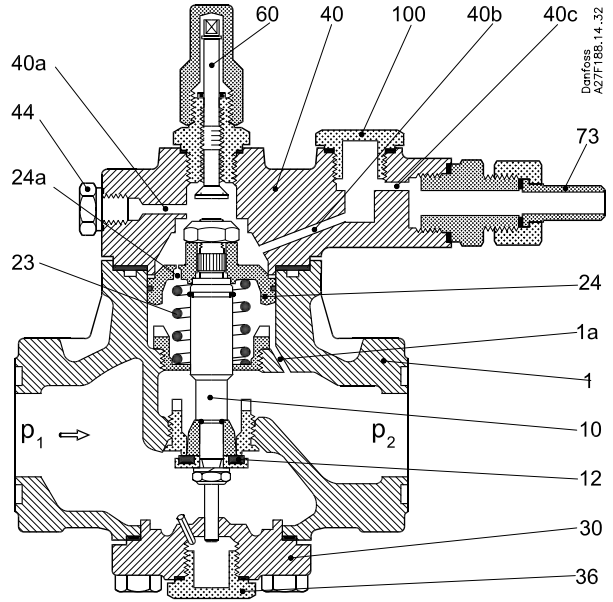

2

Danfoss  
A27F186.14, 32

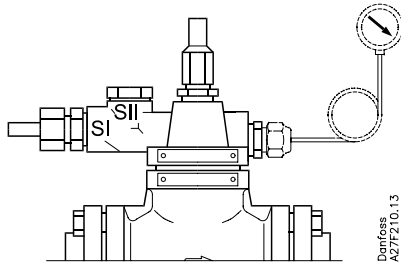

PMFH

3

Danfoss  
A27F210.13

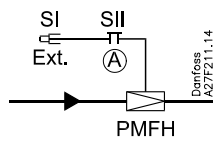

4

Danfoss  
A27F21.14

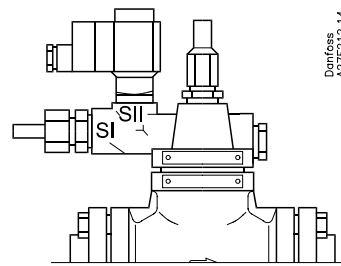

PMFH+EVM

5

Danfoss  
A27F212.14

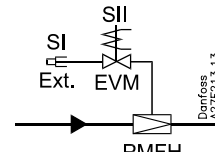

6

Danfoss  
A27F213.13

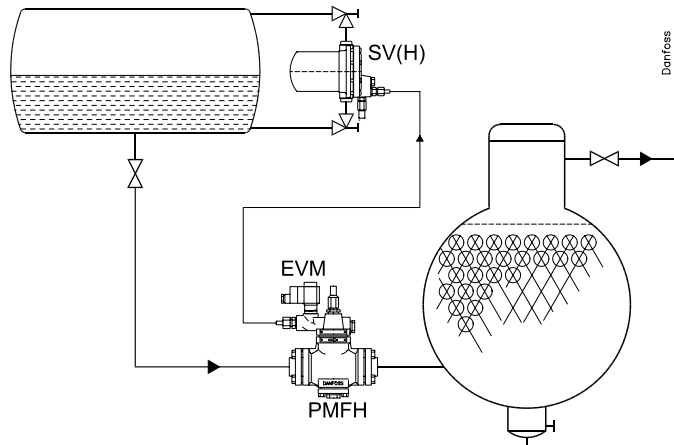

7

Danfoss  
A27F197.15

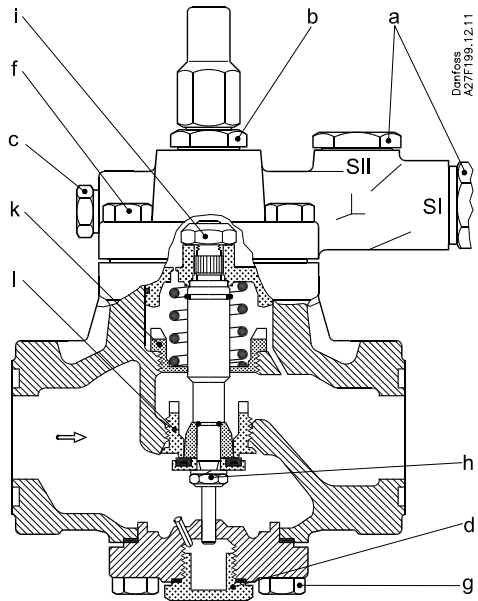

8

Table I

Pos. Item.	Tilspændingsmoment i Nm (10 Nm = 1 kpm) Tightening torque in Nm (1 Nm = 0.74 lb force ft) Anzugsmoment in Nm (10 Nm = 1 kpm) Couple de serrage en Nm (10 Nm = 1 kgf.m)				
	PMFH Størrelse Size Größe Dimension				
	80	125	200	300	500
a	50				
b	50				
c	30				
d	50				
e	60			80	
f	40		60		80
g	40		60		80
h	17	34		49	
i	30				
k	80	100			120
l	50	60	100		120

---

**Installation**

---

**Refrigerants**

Applicable to all common non-flammable refrigerants, including R717 and non-corrosive gases/liquids dependent on sealing material compatibility.

Flammable hydrocarbons are not recommended. The valve is only recommended for use in closed circuits. For further information please contact Danfoss.

**Temperature range**

PMFH:  $-60/+120^{\circ}\text{C}$  ( $-76/+248^{\circ}\text{F}$ )

**Pressure range**

PMFH: The valves are designed for a max. working pressure of 28 bar g (406 psi g).

**Technical data**

PMFH can be used in suction, liquid, hot-gas and liquid/vapour lines. The PMFH regulates the flow of the medium by two step on/off function, depending on the control impulse from the screwed-on pilot valves.

**Design**

See fig. 2

1. Valve body
- 1a. Channel in valve body 1
10. Valve spindle
12. Valve plate
23. Spring
24. Servo piston
- 24a. Channel in servo piston 24
30. Bottom cover
36. Drain plug
40. Cover
- 40a. b. c. Channels in cover 40
44. Pressure gauge connection
60. Manual operating spindle
73. Pilot connection
100. Blanking plug

**Installation**

Flange set for the PMFH is delivered separately. The valve must be installed with the arrow in the direction of the flow and the top cover upwards (fig. 1). The top cover can be rotated 4 X 90° in relation to the valve body.

The valve is fitted with a spindle for manual opening.

When an external pilot valve is used, the pilot line must be connected to the upper side of the main line so that any dirt and oil from the plant will not find its way into the pilot line.

The PMFH valve can be controlled by the SV float valve as shown on fig. 7. Please refer to SV instruction guidelines.

The valve is designed to withstand a high internal pressure. However, the piping system should be designed to avoid liquid traps and reduce the risk of hydraulic pressure caused by thermal expansion. It must be ensured that the valve is protected from pressure transients like "liquid hammer" in the system.

**Welding**

If using welding flanges, only materials and welding methods, compatible with the flange material must be welded to the flanges. The flanges should be cleaned internally to remove welding debris on completion of welding and before the valve is inserted.

The valve housing and flanges must be free from stresses (external loads) after installation.

PMFH valves must not be mounted in systems where the outlet side of the valve is open to atmosphere. The outlet side of the valve must always be connected to the system or properly capped off, for example with a welded-on end plate.

**Colours and identification**

The PMFH valves are Zinc-Chromated in the factory. If further corrosion protection is required, the valves can be painted.

Precise identification of the valve is made via the ID plate on the top cover. The external surface of the valve housing must be prevented against corrosion with a suitable protective coating after installation and assembly.

Protection of the ID plate when repainting the valve is recommended.

---

**Maintenance**

---

**Service**

The PMFH valves are easy to dismantle and most of its parts are replaceable. When the bottom cover is removed, the strainer can be taken out for cleaning. Do not open the valve while the valve is still under pressure.

- Check that the O-ring or gaskets have not been damaged.
- Check that the spindle is free of scratches and impact marks.
- If the teflon ring has been damaged, the parts must be replaced.

**Assembly**

Remove any dirt from the body before the valve is assembled. Check that all channels in the valve are not blocked with particles or similar.

**Tightening**

*Tightening torques*

See fig. 8 and table 1.

Use only original Danfoss parts, including packing glands, O-rings and gaskets for replacement. Materials of new parts are certified for the relevant refrigerant.

In cases of doubt, please contact Danfoss.

Danfoss accepts no responsibility for errors and omissions. Danfoss Industrial Refrigeration reserves the right to make changes to products and specifications without prior notice.









**DECLARATION OF CONFORMITY**  
The Pressure Equipment Directive 97/23/EC



**Name and Address of Manufacturer within the European Community**

Danfoss Industrial Refrigeration A/S  
Stormosevej 10  
PO Box 60  
DK-8361 Hasselager  
Denmark

**Description of Pressure Equipment**

Refrigerant main regulating valves  
**Type PM, PML, PMLX, PMFH, PMFL, MRV, MEV**

Nominal bore	<b>DN32-150 mm</b> (1 <sup>1</sup> / <sub>4</sub> - 6 in.)	
Classified for	<b>Fluid Group I</b> (all refrigerants (toxic, nontoxic, flammable and nonflammable)). For further details / restrictions - see Installation Instruction.	
Temperature range	All	-60°C (-76°F) to 120°C (248°F)
Maximum allowable working pressure		<b>28 bar</b> (406 psi)

**Conformity and Assessment Procedure Followed**

Category	<b>II</b>	<b>III</b>
Module	<b>D1</b>	<b>B1+D</b>
Certificate ID	<b>D1: 07 202 0511 Z 0009/1/H-0002</b>	<b>B1: 07 202 0511 Z 0074/1/H-0001</b> <b>D: 07 202 0511 Z 0009/1/H-0001</b>
Nominal bore	DN 32-125 mm (1 <sup>1</sup> / <sub>4</sub> -5 in)	DN150 mm (6 in)

**Name and Address of the Notified Body which carried out the Inspection**

TÜV-Nord e.V.  
Grosse Bahnstrasse 31  
22525 Hamburg, Germany



**Name and Address of the Notified Body monitoring the Manufacturer's Quality Assurance System**

TÜV-Nord e.V.  
Grosse Bahnstrasse 31  
22525 Hamburg, Germany

**References of Harmonised Standards used**

**References of other Technical Standards and Specifications used**

prEN 12284                      DIN 3158  
EN 1563                         AD-Merkblätter

**Authorised Person for the Manufacturer within the European Community**

**Name:** Morten Steen Hansen                      **Title:** Production Manager

**Signature:** Morten Steen Hansen                      **Date:** 16/01/2002