

Thermostatically operated
cooling water valves
Type FJVA

on thermostatically operated cooling water valves
Type FJVA

Introduction

Thermostatically operated valves are used for the infinite, proportional regulation of flow quantity, depending on the setting and the sensor temperature.

The Danfoss range of thermostatic valves includes a series of industrial products for both cooling and heating regulation. The valves are self-acting, i.e. they operate without the supply of auxiliary energy such as electricity or compressed air.

Because the valves constantly match flow quantity to demand they are especially suitable for temperature regulation. The required temperature is maintained constant with no overconsumption of:
 - cooling water in cooling systems,
 - hot water or steam in heating systems.
 Thus operating economy is always reasonable.

For further information on thermostatically operated valves for heating regulation, please contact Danfoss.

Function

General

FJVA valves consist of three main elements:

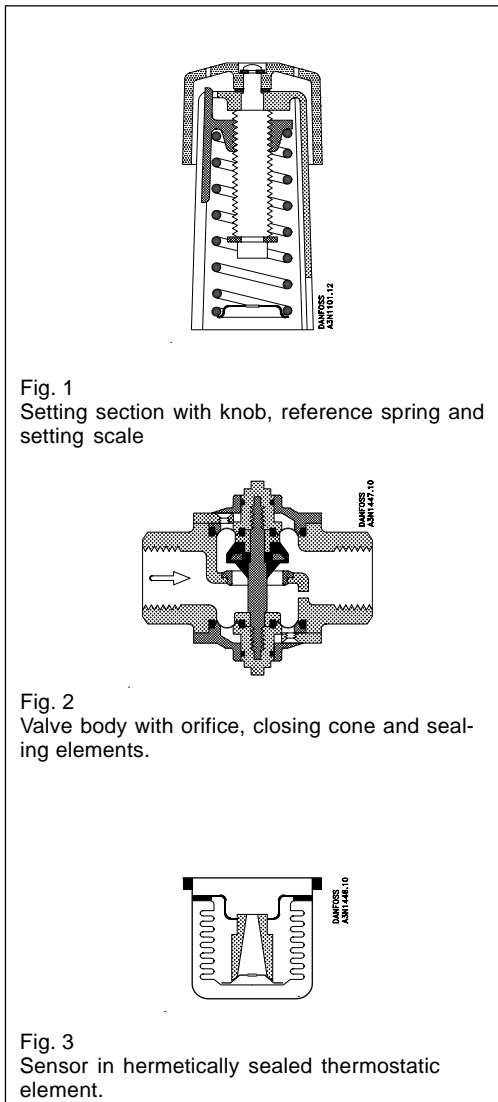

When the three elements are built together and the valve is installed, the function sequence is as follows:

1. A temperature-dependent pressure - charge vapour pressure - builds up in the sensor.
2. This pressure is transferred to the valve via the bellows and acts as an opening or closing force.
3. The knob on the setting section and the spring exert a force that acts counter to the bellows.
4. When balance is created between the two opposing forces, the valve spindle remains in its position.
5. If the sensor temperature - or the setting - is changed, the point of balance becomes displaced and the valve spindle moves until balance is re-established, or the valve is fully open or closed.
6. On sensor temperature change the flow quantity change is approximately proportional.

The illustrations show an FJVA cooling water valve, but the function principle applies to all types of thermostatic valves.

**Type FJVA
for neutral media**

Application



FJVA valves are for applications where, because of installation problems, etc., it is desirable to avoid using a capillary tube. This applies mainly where regulation accuracy requirements are more moderate and where an integral bypass can be accepted.

In FJVA the whole bellows element is used as the sensor. The valve reacts to the cooling water temperature and therefore it must always be installed in the return line. Thus, indirect regulation is involved.

To ensure the medium temperature to influence the thermostatic element, when the valve is closed, a by-pass in the valve (see fig. 4) provides a constant minimal flow through the valve.

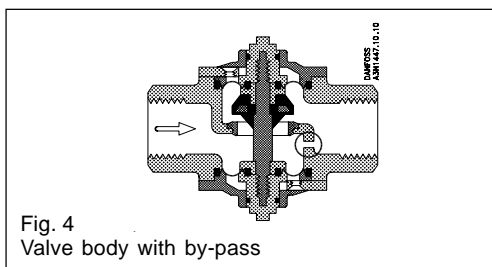

Fig. 4
Valve body with by-pass

Valves of this type operate with significantly longer time constants than AVTA valves where the sensor is located at the point at which the temperature is to be regulated. FJVA is mainly used in systems where large and sudden load changes do not occur.

Ordering

Regulation range 0 → +30°C
Media temperature -25°C → +55°C
Differential pressure 0 → 10 bar

Connection	k _v value	Bypass ¹⁾	Type	Code no.
G 1/2	1.9	∅ 2	FJVA 15	003N8210
G 3/4	3.4	∅ 2	FJVA 20	003N8244
G 1	5.5	∅ 2.5	FJVA 25	003N8245

Regulation range +25 → +65°C
Media temperature -25°C → +90°C
Differential pressure 0 → 10 bar

Connection	k _v value	Bypass ¹⁾	Type	Code no.
G 1/2	1.9	∅ 2	FJVA 15	003N8211
		∅ 1.5		003N8247
G 3/4	3.4	∅ 2	FJVA 20	003N8215
G 1	5.5	∅ 2.5	FJVA 25	003N8216

¹⁾ Bypass k_v: ∅ 2 mm: 0.11 m³/h
∅ 1.5 mm: 0.06 m³/h
∅ 2.5 mm: 0.16 m³/h

Type FJVA
for neutral media

Dimensions and weights

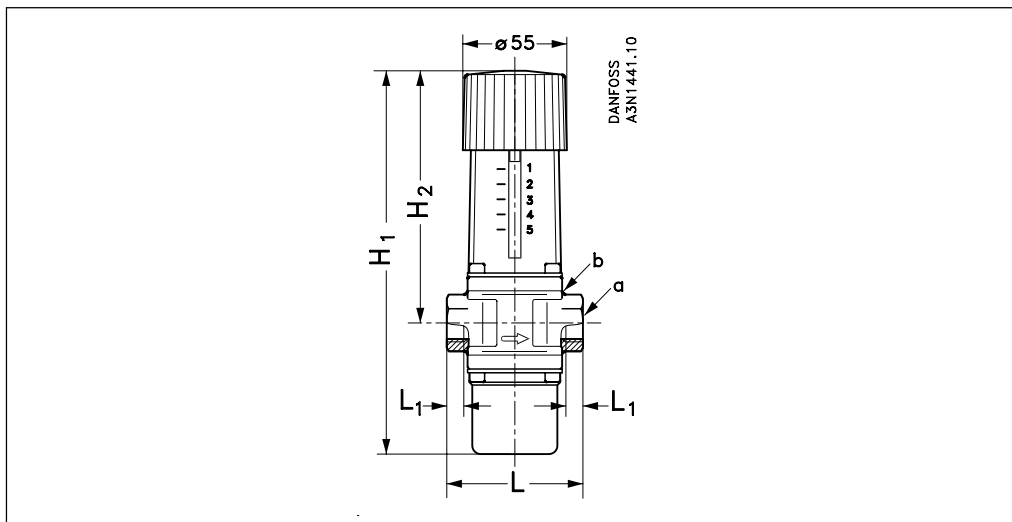

Type	H ₁ [mm]	H ₂ [mm]	L [mm]	L ₁ [mm]	a	b [mm]	Weight [kg]
FJVA 15	205	133	72	14	G 1/2	○ 27	0.9
FJVA 20	205	133	90	16	G 3/4	○ 32	1.0
FJVA 25	215	138	95	19	G 1	○ 41	1.1

Materials

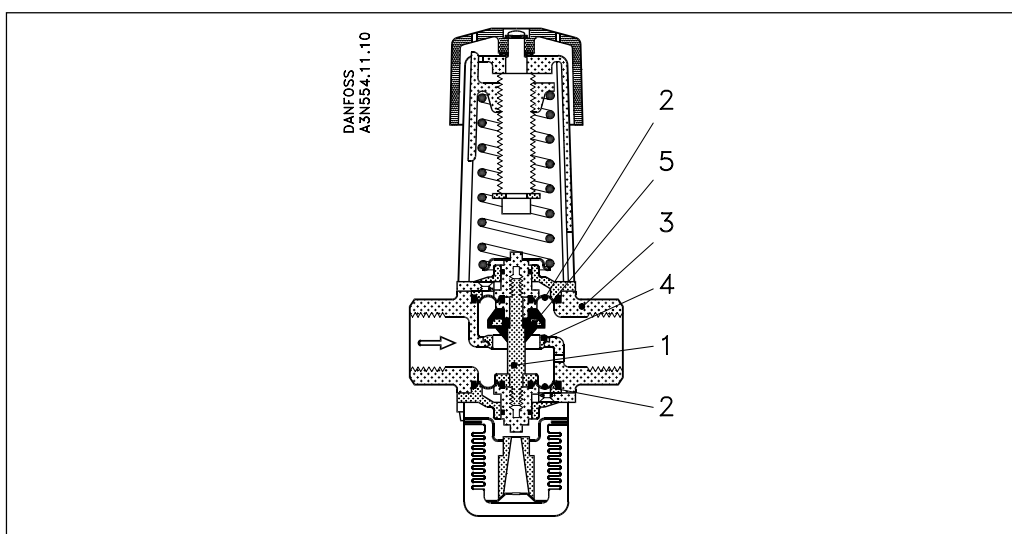

Materials - parts in contact with the medium

No.	Description	Material	
1	Spindle	Brass	W.no. 2.0401
2	Diaphragms	Rubber - ethylene - propylene (EPDM)	
3	Valve body and other metal parts	Forged brass	W.no. 2.0402
4	Valve cone	Nitrile rubber (NBR)	
5	Valve seat	Stainless steel	W.no. 1.4305 / AISI 303

Spare parts and accessories

for thermostatically operated cooling water valves
Type FJVA



Spare parts and accessories

Service elements

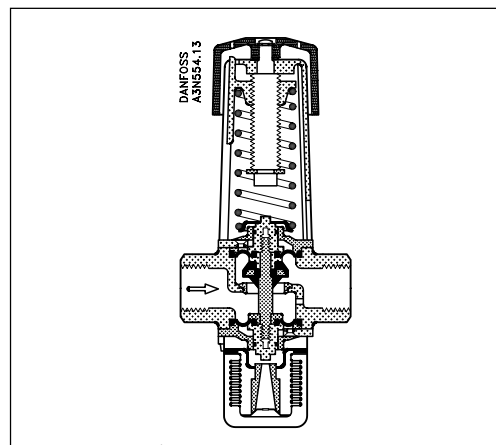
Temperature range [°C]	Code no.
0 → 30	003N0285
25 → 65	003N0084

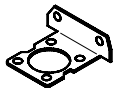

Accessories

	Designation	Description	Code no.
	Mounting bracket	For FJVA	003N0388
	2 o-rings 2 diaphragms Valve cone	For FJVA 10/15 For FJVA 20 For FJVA 25	003N4006 003N4007 003N4008

Installation

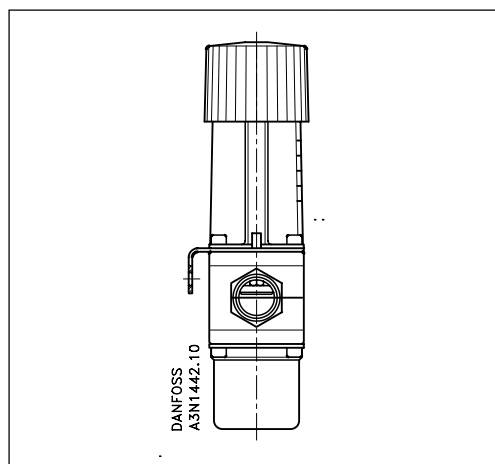

The valves can be installed in any position. An arrow on the valve body indicates the direction of flow.

FJVA valves are also marked so that the letters RA can be read straightforwardly. The installation of an FV filter ahead of the valve is recommended - see separate data sheet DKACV.PD.600.B.

If a mounting bracket is used - see "Accessories" above - it must always be between valve body and setting section (see illustration).

on thermostatically operated cooling water valves
Type FJVA

Sizing

When sizing and selecting thermostatic valves, it is most important to ensure that the valve is able to give the necessary quantity of cooling water at any time, irrespective of the load. Therefore, to select a suitable size of valve, it is necessary to know the precise amount of cooling required. On the other hand, to avoid the risk of unstable regulation (hunting), the valve should not be oversized. The type of charge must be selected on the basis of the temperature to be maintained, and on an assessment of the characteristics of each type, as described in the foregoing.

In general the aim should be to select the smallest valve capable of giving the required flow.

Valve size

The following data are used when selecting valve size:

- Required cooling water flow, Q (m³/h)
- Temperature rise in cooling water, Δt (°C)
- Differential pressure across valve, Δp (bar).

With fully open valve the differential pressure should be around 50% of the total pressure drop across the cooling system.

The diagrams on page 7 are intended to make valve sizing easier.

Fig. 5 - Relation between heat quantity (kW) and cooling water quantity

Fig. 6 - Graphs of k_v values

Fig. 7 - Valve operating range

Fig. 8 - Flow quantities as a function of pressure drop [Δp]

on thermostatically operated cooling water valves
Type FJVA

Sizing

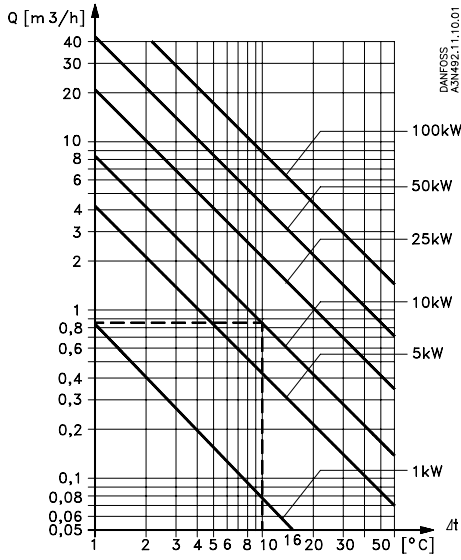

Fig. 5
Heating or cooling with water.
Example: Necessary cooling output 10 kW, with $\Delta t = 10\text{ }^\circ\text{C}$.
Required flow 0.85 m³/h.

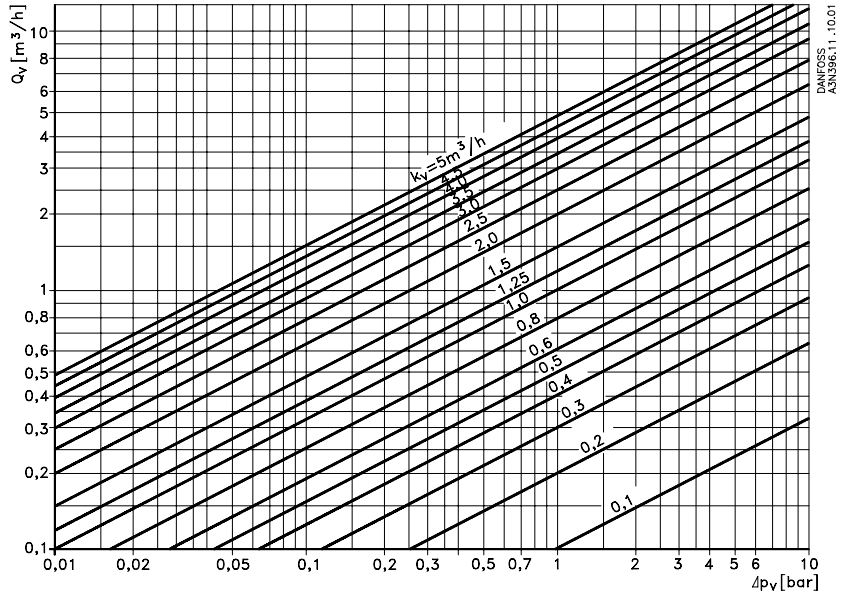

Fig. 6
Relation between water quantity and pressure drop across valve.
Example: Flow 0.85 m³/h with a pressure drop of 1.5 bar.
The k_v value becomes 0.7 m³/h.

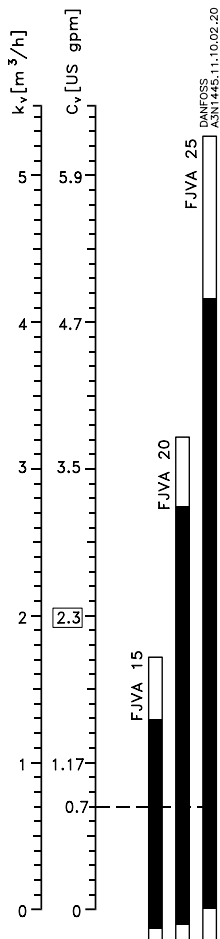

Fig. 7
Nomogram showing the valve k_v ranges. k_v values are always given for the water flow in m³/h with a pressure drop [Δp] of 1 bar. The valve should be selected so that the necessary k_v value lies in the middle of the regulation range.
Example: FJVA 15 is the most suitable for a k_v value of 0.7.

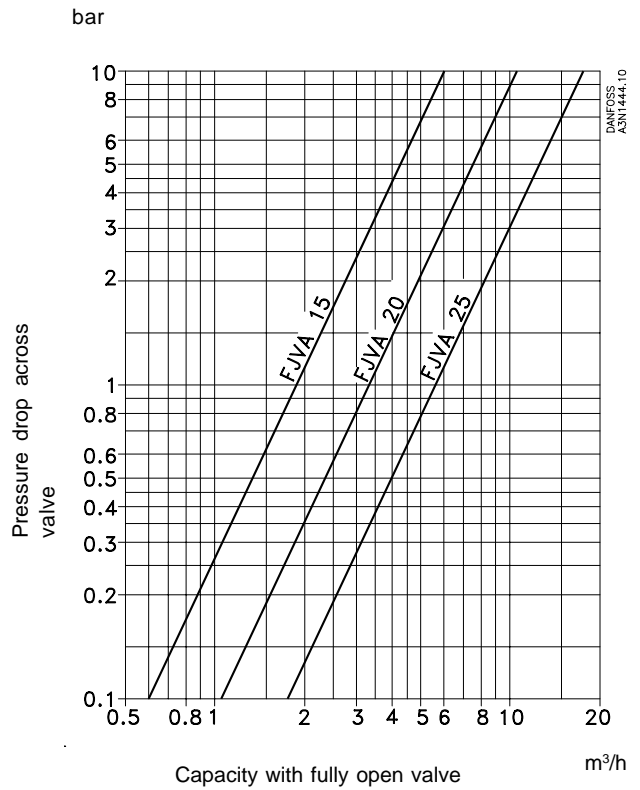

Fig. 8
Valve flow quantity in fully open position, as a function of pressure drop [Δp].

Type FJVA

Danfoss can accept no responsibility for possible errors in catalogues, brochures and other printed material. Danfoss reserves the right to alter its products without notice. This also applies to products already on order provided that such alterations can be made without subsequential changes being necessary in specifications already agreed. All trademarks in this material are property of the respective companies. Danfoss and the Danfoss logotype are trademarks of Danfoss A/S. All rights reserved.
